

DIRECT SUPPORT AND
GENERAL SUPPORT MAINTENANCE MANUAL

COMMUNICATION SYSTEM,
CONTROL ELEMENT,
CENTRAL PROCESSOR

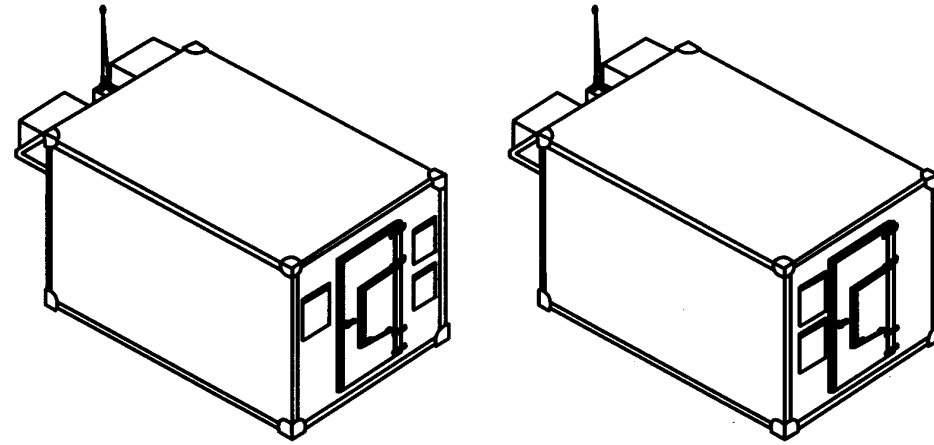

AN/TYQ-30(V)1
(NSN 5895-01-280-3568) (EIC: HYK)

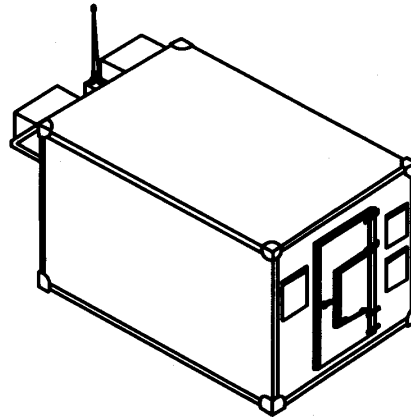

AN/TYQ-30(V)2
(NSN 5895-01-280-3567) (EIC: HYL)

VOLUME 2
WIRING/INTERCONNECT DATA



WARNING
HIGH VOLTAGE

5 SAFETY STEPS TO FOLLOW IF SOMEONE IS THE VICTIM OF ELECTRICAL SHOCK

1 DO NOT TRY TO PULL OR GRAB THE INDIVIDUAL

2 IF POSSIBLE, TURN OFF THE ELECTRICAL POWER

3 IF YOU CANNOT TURN OFF THE ELECTRICAL POWER, PULL, PUSH, OR LIFT THE PERSON TO SAFETY USING A DRY WOODEN POLE OR A DRY ROPE OR SOME OTHER INSULATING MATERIAL

4 SEND FOR HELP AS SOON AS POSSIBLE

5 AFTER THE INJURED PERSON IS FREE OF CONTACT WITH THE SOURCE OF ELECTRICAL SHOCK, MOVE THE PERSON A SHORT DISTANCE AWAY AND IMMEDIATELY START ARTIFICIAL RESUSCITATION

- 208 volts ac, 120 volts ac, and 288 (+ 144 to -144) volts dc are used in this equipment. These voltages can kill on contact. Observe the following precautions:**
- Before connecting primary power or the signal cables, connect a ground strap from the ground lug on the power entry panel to earth ground. Do not remove this ground strap until the signal cables and primary power cable have been disconnected.
 - Never work on the equipment unless there is another person nearby who is familiar with the operation and the hazards of the equipment and who can administer first aid. When operators aid the technicians, the operators must be warned about dangerous areas.
 - Whenever possible the input power supply to the equipment must be shut off before beginning work on the equipment. Take particular care to ground every capacitor likely to hold a dangerous potential. When working inside the equipment, after the power has been turned off, always ground every part before touching it.
 - Be careful not to contact the 208 volt ac, 115 volt ac, or 144 volt dc connections when installing or servicing the equipment. Avoid all open terminals, power ports, and live circuits.
 - Whenever the nature of the operation permits, keep one hand away from the equipment to reduce the hazard of current flowing through the vital organs of the body.
 - If a circuit breaker does not stay in ON position when closed, do not attempt to close it repeatedly. That could create an overload situation hazardous to personnel and equipment. Instead, investigate the cause of the problem. Correct situation before attempting to close the breaker again.

WARNING

Do not be misled by the term "LOW VOLTAGE." Potentials as low as 50 volts may cause DEATH under adverse conditions.

RF RADIATION

RF energy is present near the antenna during radio transmission. Maintain at least 30 Inches between shelter antenna and personnel during transmission.

WARNING

RF ENERGY IS PRESENT NEAR THE ANTENNA DURING TRANSMISSION. MAINTAIN AT LEAST 30 INCHES BETWEEN VEHICULAR ANTENNA AND PERSONNEL DURING TRANSMISSIONS.

WARNING

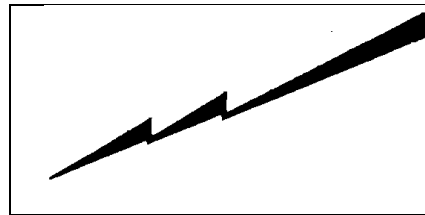

HIGH VOLTAGE

EXISTS AT CONNECTOR J1 ON VEHICULAR MOUNTING ADAPTER. AVOID PERSONNEL INJURY: BE SURE J1 IS COVERED OR CAPPED WHEN NOT IN USE.

WARNING

Death or serious injuries can result:

- When antenna tip caps are not installed on antennas.
- When a tied-down antenna hits a fixed object such as an overhead bridge, tree limb, etc. Flying antenna parts might strike nearby personnel.

WARNING

HEAVY EQUIPMENT

Much of this equipment weighs over 35 pounds and can cause serious injury if lifted or carried alone. Observe the following safety precautions:

- **MULTIPLE PERSON LIFT**
Some equipment items bear warnings that multiple person lift is required. Do not attempt to lift, carry, or move these items by yourself. Get help.
- **MECHANICAL LIFT**
Some equipment items bear warnings that mechanical lift is required. Do not attempt to lift, carry, or move these items without the specified mechanical lift device.

USE OF COMPRESSED AIR

Compressed air is dangerous and can cause serious bodily harm if protective means or methods are not observed to prevent a chip or particle (of whatever size) from being blown into the eyes or unbroken skin of the operator or other personnel. Compressed air shall not be used for cleaning purposes except where reduced to less than 30 pounds per square inch gauge (30 psig) and then only with effective chip guarding and personnel protective equipment (industrial safety glasses and full faceshield).

USE OF CLEANING SOLVENT

Trichlorotrifluoroethane, trichloroethane and similar chemical solvents will no longer be used for ordinary cleaning of equipment. These substances threaten public health and the environment by destroying ozone in the earth's upper atmosphere. Suitable nonhazardous cleaning materials will be used instead, such as a clean cloth, water and mild detergent.

For First Aid, refer to FM 21-11.

OPS SHELTER FOLD-DOWN STEP HAZARD

If the 30(V)1 OPS shelter is on a 5-ton truck, follow this WARNING

The shelter tiedown cable (right rear) obstructs the bottom fold-down step on the outside wall of the shelter. When using this fold-down step, the soldier's boot may become entangled between the cable and the shelter wall, thus causing a safety hazard (trip/fall).



CAUTION



EQUIPMENT CONTAINS SENSITIVE TO DAMAGE BY ELECTROSTATIC DISCHARGE (ESD).

USE PRECAUTIONARY PROCEDURES WHEN TOUCHING, REMOVING OR INSERTING PRINTED CIRCUIT BOARDS.

GENERAL HANDLING PROCEDURES FOR ESD ITEMS

USE WRIST GROUND STRAPS OR MANUAL GROUNDING PROCEDURES. KEEP ESD ITEMS IN PROTECTIVE COVERING WHEN NOT IN USE. GROUND ALL ELECTRICAL TOOLS AND TEST EQUIPMENT.

PERIODICALLY CHECK CONTINUITY AND RESISTANCE OF GROUNDING SYSTEM. USE ONLY METALIZED SOLDER SUCKERS. HANDLE ESD ITEMS ONLY IN PROTECTED AREAS.

CAUTION

MANUAL GROUNDING PROCEDURE

MAKE CERTAIN EQUIPMENT IS POWERED DOWN. TOUCH GROUND PRIOR TO REMOVING ESD ITEMS.

TOUCH PACKAGE OF REPLACEMENT ESDS ITEM TO GROUND BEFORE OPENING. TOUCH GROUND PRIOR TO INSERTING REPLACEMENT ESD ITEMS.



ESD PROTECTIVE PACKAGING AND LABELING



INTIMATE COVERING OF ANTISTATIC MATERIAL WITH AN OUTER WRAP OF EITHER TYPE 1 ALUMINIZED MATERIAL OR CONDUCTIVE PLASTIC FILM OR HYBRID LAMINATED BAGS HAVING AN INTERIOR OF ANTISTATIC MATERIAL WITH AN OUTER LAYER OF METALIZED MATERIAL. LABEL WITH SENSITIVE ELECTRONIC SYMBOL AND CAUTION NOTE, AS ABOVE.

CAUTION

Devices such as CMOS, NMOS, VMOS, HMOS, thin-film resistors PMOS, and MSOFET used in many equipments can be damaged by static voltages present in most repair facilities. Most of the components contain internal gate protection circuits that are partially effective, but sound maintenance practice and the cost of equipment failure in time and money dictate careful handling of all electrostatic sensitive components.

The following precautions should be observed when handling all electrostatic sensitive components and units containing such components.

Failure to observe all of these precautions can cause permanent damage to the electrostatic sensitive device. This damage can cause the device to fail immediately or at a later date when exposed to an adverse environment.

STEP

1 Turn off and/or disconnect all power and signal source and loads used with the unit.

STEP

2 Place the unit on grounded conductive work surfaces.

STEP

3 Ground the repair operator using a conductive wrist strap or other device using a 1 M Ω series resistor to protect the operator.

STEP

4 Ground any tools (including soldering equipment) that will contact the unit. Contact with the operator's hand provides a sufficient ground for tools that are other wise electrically isolated.

STEP

5 All electrostatic sensitive replacement components are shipped in conductive foam or tubes and must be stored in the original shipping container until installed.

STEP

6 When these devices and assemblies are removed form the unit, they should be placed on the conductive work surface or in conductive containers.

STEP

7 When not being worked on, wrap disconnected circuit boards in aluminum foil or in plastic bags that have been coated or impregnated with a conductive material.

STEP

8 Do not handle these devices unnecessarily or remove from their packages until actually used or tested.

STEP

9 Static pads do not mount on conductive surfaces. No test equipment is to be placed on static pads. No equipment resting on a static pad is to be plugged into an electrical outlet.

**DIRECT SUPPORT AND GENERAL SUPPORT MAINTENANCE MANUAL
COMMUNICATION SYSTEM, CONTROL ELEMENT (CSCE)
CENTRAL PROCESSOR AN/TYQ-30(V)1 (NSN 5895-01-280-3568) (EIC: HYK)
AND
CENTRAL PROCESSOR AN/TYQ-30(V)2 (NSN 5895-01-280-3567) (EIC: HYL)**

INTRODUCTION

SCOPE

This technical manual contains the wiring and interconnect drawings referenced in TM 11-5895-1392- 34-1. Included in this volume are schematic diagrams, wiring diagrams, cable assembly drawings, and point-to-point wiring lists.

DRAWING DESCRIPTIONS

Each drawing has a drawing number (A309xxxx). Many of these drawings consist of more than one sheet (page). Each sheet of each multiple sheet drawing has a sheet number in addition to the drawing number. The wire list sheets are A size (8-1/2 by 11 inch), shown as two sheets per 11 by 17 inch page. The schematic, wiring, and assembly drawings are B size (11 by 17 inch) pages.

DRAWING ARRANGEMENT

The 11 by 17 inch pages are printed on one side only. All drawings, are arranged in drawing number (A309xxxx) and sheet number sequence. Conventional page numbers have been added, in addition to the drawing and sheet numbers.

CROSS-REFERENCING

The following cross-reference indexes are provided to help you find the desired drawing:

- Unit Reference Designator to Drawing Number
- Unit Name to Drawing Number
- Cable Reference Designator to Drawing Number
- Cable Name to Drawing Number

The first digit in the reference designator column of each cross-reference index is the major functional group as defined by the Maintenance Allocation Chart (MAC):

- 1 = Automatic Data Processing (ADP) Shelter Equipment
- 2 = Remote Terminal Cluster (RTC) Equipment
- 3 = External Cables (Power, ADP shelter to RTC, etc.)
- 4 = Operation (OPN) Shelter Equipment (AN/TYQ-30(V)1 only)

REPORTING ERRORS AND RECOMMENDING IMPROVEMENTS

You can help improve this manual. If you find any mistakes or if you know of a way to improve the procedures, please let us know. Mail your letter, DA Form 2028 (Recommended Changes to Publications and Blank Forms) or DA Form 2028-2 located in the back of this manual direct to: Commander, US Army Communications-Electronics Command and Fort Monmouth, ATTN: AMSEL-LC-LM-LT, Fort Monmouth, NJ 07703-50007. A reply will be furnished to you.

Para	Page
VOLUME 2. WIRING/INTERCONNECT DATA	
INTRODUCTION	i
Scope	i
Drawing Descriptions	i
Drawing Arrangement	i
Cross-Referencing	i
DRAWING LIST	ii
UNIT REFERENCE DESIGNATOR TO DRAWING NUMBER INDEX.....	iii
UNIT NAME TO DRAWING NUMBER INDEX	iv
CABLE REFERENCE DESIGNATOR TO DRAWING NUMBER INDEX	v
CABLE NAME TO DRAWING NUMBER INDEX	viii
DRAWINGS	x

DRAWING LIST

The following drawings are included in this volume. The complete drawing title, as shown in the drawing title block, is provided for each listed drawing.

Drawing Number	Title	Page
A3092660	Interconnection Diagram, ADP System-AN/TYQ-30	1
A3092662	Schematic Diagram, Power Distribution-Data Racks-AN/TYQ-30	3
A3092663	Interconnection Diagram, Remote Terminal Cluster	4
A3092668	Cable Assembly, Radio/Entry Control	5
A3092669	Cable Assembly, Thin Wire Triax	7
A3092673	Cable Assembly, LS147/Patch	9
A3092719	Cable Assembly, Filtered AC-Mod	11
A3092752	Interconnecting Diagram, OPN System-AN/TYQ-30	12
A3092761	Schematic Diagram, Black Patch Panel, OPN	14
A3092762	Wiring List, Point-to-Point, Black OPN Patch Panel	16
A3092770	Schematic Diagram, Power Distribution Panel, OPN	22
A3092771	Wiring List, Point-to-Point, Power Distribution Panel-OPN	24
A3092772	Schematic Diagram, Red Patch Panel-OPN	30
A3092777	Schematic Diagram, Power Rack-OPN.....	37
A3092778	Wiring List, Point-to-Point, Power Rack-OPN	38
A3092781	Schematic Diagram, Shelter Power-OPN	40
A3092782	Wiring List, Point-to-Point, Shelter Power-OPN	42
A3092862	Interconnection Diagram, Repeater/Station Adapter	51
A3093089	Cable Assembly, Power, Workstation	52
A3093161	Schematic Diagram, Patch Panel-Red	54
A3093171	Schematic Diagram, Black Patch Panel-AN/TYQ-30	76
A3093172	Wiring List, Point-to-Point, Black Patch Panel-AN/TYQ-30	82
A3093176	Schematic Diagram, Extension Phone	101
A3093177	Wiring List, Point-to-Point, Extension Phone	102
A3093202	Schematic Diagram, Power Distribution-ADP Shelter	107
A3093203	Schematic Diagram, Power Distribution Panel	111
A3093206	Wiring List, Point-to-Point, Power Rack	113
A3093207	Wiring List, Point-to-Point, Power Distribution/Shelter	115
A3093208	Schematic Diagram, Power Distribution-Power Rack	123
A3093209	Wiring List, Point-to-Point, Power Distribution Panel	124
A3093264	Schematic Diagram, Power Entry	131
A3093267	Wiring List, Point-to-Point, Power Entry	133
A3093320	Wiring List, Point-to-Point, Light Fixture	139
A3093365	Schematic Diagram, Group Data	141
A3093366	Wiring List, Point-to-Point, Group Data	142
A3093367	Schematic Diagram, Audio	145
A3093368	Wiring List, Point-to-Point, Audio	146
A3093476	Cable Set, Fiber Optic Ethernet Repeater Assembly	149
A3093528	Wiring Harness, Environmental Control Unit (ECU) Control	153
A3093571	Cable Set, RTC	156
A3093580	Specification Control Drawing, Power Source, Uninterruptible (UPS)	160
A3093582	Cable Assembly, LGM/Patch	180

DRAWING LIST - Continued

Drawing Number	Title	Page
A3093597	Cable Assembly, Console.....	182
A3093598	Cable Assembly, AUI.....	184
A3093599	Cable Assembly, CP/Patch	186
A3093600	Cable Assembly, WS/Patch	188
A3093601	Cable Assembly, Fiber Optic	190
A3093602	Cable Assembly, Patch/DSDI	191
A3093604	Cable Assembly, Workstation/Patch	193
A3093605	Cable Assembly, DSDI/KY68	195
A3093606	Cable Assembly, KY68/Patch.....	197
A3093607	Cable Assembly, Patch/LGM.....	199
A3093608	Cable Assembly, LGM/GM/OCU/Patch	201
A3093609	Cable Assembly, GM (ROA)/Patch	203
A3093610	Cable Assembly, Line Data Out.....	205
A3093611	Cable Assembly, Line Data in.....	206
A3093616	Cable Assembly, Entry/Antenna Control	207
A3093617	Cable Assembly, Patch/ROA.....	209
A3093620	Cable Assembly, KY68/Patch.....	211
A3093621	Cable Assembly, Patch/LDF	213
A3093622	Cable Assembly, Patch/VEP	215
A3093623	Cable Assembly, Patch/Radio	217
A3093625	Cable Assembly, FOER J3, Jumper	219
A3093628	Cable Assembly, Radio/Antenna	220
A3093629	Cable Assembly, Patch/SEP	221
A3093630	Cable Set, Data Rack-AN/TYQ-30	223
A3093631	Cable Set, Equipment Rack, OPN.....	237
A3093634	Cable Set, ADP Shelter-AN/TYQ-30	243
A3093635	Cable Assembly, Audio/Posts.....	247
A3093637	Cable Set, Shelter, OPN	249
A3093638	Cable Assembly, CP/Patch (Alarm)	253
A3093639	Cable Assembly, Radio/Patch	255
A3093640	Cable Assembly, 26 Pair Extension	257
A3093641	Cable Assembly, UPS/Patch	260
A3093642	Cable Assembly, 26 Pair	262
A3093643	Cable Assembly, Power Filtered	265
A3093644	Cable Assembly, Power 120 Vac.....	267
A3093645	Cable Assembly, Power 28 Vdc/Radio	269
A3093646	Cable Assembly, GM/Patch	271
SC-D-883963	Cable Assembly, Electrical Power	273
SC-D-883964	Cable Assembly, Electrical Power Stub	275
SM-D-811235	Cable Assembly, Signal, Electrical-U-185(B)/G Adapter Assembly	277

UNIT REFERENCE DESIGNATOR TO DRAWING NUMBER INDEX

The following cross-reference lists the reference designators of all units for which drawings are provided in this manual, in reference designator order. For each listed unit, the unit common name (Unit Name) and applicable drawing numbers are provided. For each drawing number, the functional drawing name is also provided.

Reference Designator	Unit Name	Drawing Number	Drawing Name/Function
1	ADP Shelter	A3092660 A3093202 A3093207 A3093630 A3093634 A3093264 A3093267	Interconnect Diagram, ADPE Power Distribution Schematic Power Distribution Wiring List Cable Set, Data Rack Cable Set, ADP Shelter Schematic Diagram Wiring List, Point-to-Point
1A1 (PEP)	Power Entry Panel	A3093206 A3093208	Wiring List, Point-to-Point Schematic Diagram
1A2	Power Rack	A3093206 A3093208	Wiring List, Point-to-Point Schematic Diagram
1A3	Equipment Rack	A3092662	Power Distribution Schematic
1A3A1A1	Black Patch Panel	A3093171 A3093172	Schematic Diagram Wiring List, Point-to-Point
1A3A3A1	Red Patch Panel	A3093161	Schematic Diagram
1A4A1	Group Data Assembly	A3093365 A3093366	Schematic Diagram Wiring List, Point-to-Point
1A4A2	Audio Assembly	A3093367 A3093368	Schematic Diagram Wiring List, Point-to-Point
1A10 1A11 1A12 1A13	Environmental Control Unit (ECU) Telephone Set	A3093528 A3093176 A3093177	Control Wiring Harness Schematic Diagram Wiring List, Point-to-Point
1A17	Power Distribution Unit (PDU)	A3093203 A3093209	Schematic Diagram Wiring List, Point-to-Point
1DS1 1DS2	Main Light Assembly	A3093320	Wiring List, Point-to-Point
3	Remote Terminal Cluster (RTC)	A3092663 A3093571	Interconnect Diagram Cable Set

UNIT REFERENCE DESIGNATOR TO DRAWING NUMBER INDEX - Continued

Reference Designator	Unit Name	Drawing Number	Drawing Name/Function
3A1A1	Repeater/Station Adapter (RSA)	A3092862 A3093476	Interconnect Diagram Cable Set
4	OPN Shelter	A3092752 A3092781 A3092782 A3093631 A3093637	Interconnect Diagram Power Distribution Schematic Power Distribution Wiring List Cable Set, Equipment Rack Cable Set, OPN Shelter
4A1	Power Entry Panel	A3093264 A3093267	Schematic Diagram Wiring List, Point-to-Point
4A2	Power Rack	A3092777 A3092778	Schematic Diagram Wiring List, Point-to-Point
4A3A1	Red Patch Panel	A3092772	Schematic Diagram
4A3A2	Black Patch Panel	A3092761 A3092762	Schematic Diagram Wiring List, Point-to-Point
4A3A3	Repeater/Station Adapter	A3092862 A3093476	Interconnect Diagram Cable Set
4A4A1	Audio Assembly	A3093367 A3093368	Schematic Diagram Wiring List, Point-to-Point
4A10 4A11	Environmental Control Unit (ECU)	A3093528	Control Wiring Harness
4A12 4A13	Telephone Set	A3093176 A3093177	Schematic Diagram Wiring List, Point-to-Point
4A17	Power Distribution Unit	A3092770 A3092771	Schematic Diagram Wiring List, Point-to-Point
4A20 4A21	Telephone Set	A3093176 A3093177	Schematic Diagram Wiring List, Point-to-Point
4DS1 4DS2	Main Light Assembly	A3093320	Wiring List, Point-to-Point

UNIT NAME TO DRAWING NUMBER INDEX

The following cross-reference lists the common names (Unit Name) of all units for which drawings are provided in this manual, in alphabetical order. For each listed common unit, the reference designator and applicable drawing numbers are provided. For each drawing number, the functional name is also provided. No drawings are provided for unit names not listed.

Unit Name	Reference Designator	Drawing Number	Drawing Name/Function
ADP Shelter	1	A3092660 A3093202 A3093207 A3093630 A3093634	Interconnect Diagram, ADPE Power Distribution Schematic Power Distribution Wiring List Cable Set, Data Rack Cable Set, ADP Shelter
Audio Assembly	1A4A2 4A4A1	A3093367 A3093368	Schematic Diagram Wiring List, Point-to-Point Black Patch Panel
ADP Shelter	1A3A1A1	A3093171 A3093172	Schematic Diagram Wiring List, Point-to-Point
OPN Shelter	4A3A2	A3092761 A3092762	Schematic Diagram Wiring List, Point-to-Point
Environmental Control Unit (ECU)	1A10 1A11 4A10 4A11	A3093528	Control Wiring Harness
Equipment Rack ADP Shelter	1A3	A3092662	Power Distribution Schematic
OPN Shelter	4A3	None	
Group Data Assembly	1A4A1	A3093365 A3093366	Schematic Diagram Wiring List, Point-to-Point
Main Light Assembly	1DS1 1DS2 4DS1 4DS2	A3093320	Wiring List, Point-to-Point
OPN Shelter	4	A3092752 A3092781 A3092782	Interconnect Diagram Power Distribution Schematic Power Distribution Wiring List

A3093631 Cable Set, Equipment Rack
A3093637 Cable Set, OPN Shelter

UNIT NAME TO DRAWING NUMBER INDEX - Continued

Unit Name	Reference Designator	Drawing Number	Drawing Name/Function
Power Distribution Unit (PDU) ADP Shelter	1A17	A3093203 A3093209	Schematic Diagram Wiring List, Point-to-Point
OPN Shelter	4A17	A3092770 A3092771	Schematic Diagram Wiring List, Point-to-Point
Power Entry Panel (PEP) Power Rack ADP Shelter	1A1 4A1 1A2	A3093264 A3093267 A3093206 A3093208	Schematic Diagram Wiring List, Point-to-Point Wiring List, Point-to-Point Schematic Diagram
OPN Shelter	4A2	A3092777 A3092778	Schematic Diagram Wiring List, Point-to-Point
Red Patch Panel ADP Shelter	1A3A3A1	A3093161	Schematic Diagram
OPN Shelter	4A3A1	A3092772	Schematic Diagram
Remote Terminal Cluster (RTC)	3	A3092663 A3093571	Interconnect Diagram Cable Set
Repeater/Station Adapter (RSA)	3A1A1 4A3A3	A3092862 A3093476	Interconnect Diagram Cable Set
Telephone Set	1A12 1A13 4A12 4A13 4A20 4A21	A3093176 A3093177	Schematic Diagram Wiring List, Point-to-Point

CABLE REFERENCE DESIGNATOR TO DRAWING NUMBER INDEX

This cross-reference lists the reference designators of all AN/TYQ-30(V)1/2 cables, in reference designator order. For each listed cable, the cable assembly drawing number and cable functional name are provided. The cable assembly drawing is the drawing that provides information required to repair the cable. The functional cable name column provides a check on the cable reference designator. Cable reference designators not listed in the cable number column are not used.

Reference Designator	Cable Assembly Drawing Number	Cable Function Name
1W1	None	Power, FOER A3A3A3A1
1W2	A3092669	Ethernet, FOER ESTA/FOER ESTA
1W3	A3093601	Fiber Optic, FOER/FOEP
1W4	A3092669	Ethernet, FOER ESTA/DBMP ESTA
1W5	A3093601	Fiber Optic, FOER/FOEP
1W6	A3093605	Data, DSDI 1/DSVT 1
1W7	A3093606	Data, Black Patch/DSVT 1
1W8	A3093607	Data, Black Patch/GM
1W9	A3093644	Power, DSDI 1
1W10	A3093605	Data, DSDI 2/DSVT 2
1W11	A3093606	Data, Black Patch/DSVT 2
1W12	A3093607	Data, Black Patch/GM
1W13	None	Power, FOER A3A3A3A3
1W14	A3093599	Data, Red Patch/CP1
1W15	A3093602	Data, Red Patch/DSDI 1
1W16	A3093644	Power, DSDI 2
1W17	A3093605	Data, DSDI 3/DSVT 3
1W18	A3093606	Data, Black Patch/DSVT 3
1W19	A3092669	Ethernet, DBMP ESTA/CP1 ESTA
1W20	A3093599	Data, Red Patch/CP1
1W21	A3093602	Data, Red Patch/DSDI 2
1W22	A3093644	Power, DSDI 3
1W23	A3093599	Data, Red Patch/CP1
1W24	A3093602	Data, Red Patch/DSDI 3
1W25	A3093605	Data, DSDI 4/DSVT 4
1W26	A3093606	Data, Black Patch/DSVT 4
1W27	A3093599	Data, Red Patch/CP1
1W28	A3093602	Data, Red Patch/DSDI 4
1W29	A3093599	Data, Red Patch/CP1
1W30	A3093602	Data, Red Patch/DSDI 5
1W31	A3093644	Power, DSDI 4
1W32	A3093599	Data, Red Patch/CP1
1W33	A3093602	Data, Red Patch/DSDI 6
1W34	A3092669	Ethernet, CP1 ESTA/CP2 ESTA
1W35	A3093599	Data, Red Patch/CP1
1W36	A3093602	Data, Red Patch/DSDI 7
1W37	A3093605	Data, DSDI 5/DSVT 5

CABLE REFERENCE DESIGNATOR TO DRAWING NUMBER INDEX - Continued

Reference Designator	Cable Assembly Drawing Number	Cable Function Name
1W38	A3093606	Data, Black Patch/DSVT 5
1W39	A3093599	Data, Red Patch/CP1
1W40	A3093602	Data, Red Patch/DSDI 8
1W41	A3093644	Power, DSDI 5
1W42	A3093605	Data, DSDI 6/DSVT 6
1W43	A3093606	Data, Black Patch/DSVT 6
1W44	A3093644	Power, DSDI 6
1W45	A3093599	Data, Red Patch/CP2
1W46	A3092669	Ethernet, CP2 ESTA/WS1
1W47	A3093599	Data, Red Patch/CP2
1W48	A3093605	Data, DSDI 7/DSVT 7
1W49	A3093606	Data, Black Patch/DSVT 7
1W50	A3093599	Data, Red Patch/CP2
1W51	A3092669	Ethernet, WS1/WS2
1W52	A3093599	Data, Red Patch/CP2
1W53	A3093644	Power, DSDI 7
1W54	A3093599	Data, Red Patch/CP2
1W55	A3093605	Data, DSDI 8/DSVT 8
1W56	A3093606	Data, Black Patch/DSVT 8
1W57	A3093599	Data, Red Patch/CP2
1W58	A3093621	Data, Red Patch/LDF
1W59	A3093599	Data, Red Patch/CP2
1W60	A3093644	Power, DSDI 8
1W61	A3093599	Data, Red Patch/CP2
1W62	A3093629	Data, Red Patch/SVEP
1W63	None	Power, CP2
1W64	A3093620	Data, Telephone A12/DSVT 9
1W65	A3093606	Data, Black Patch/DSVT 9
1W68	None	Power, DBMP
1W70	A3093620	Data, Red Patch/Telephone A13
1W72	A3093089	Power, WS2
1W73	A3093089	Power, WS1
1W74	A3093620	Data, Red Patch/DSVT 10
1W75	A3093606	Data, Black Patch/DSVT 10
1W76	A3093646	GM Alarm, Red Patch/GM
1W77	A3093597	Printer Data, Red Patch/WS1
1W78	A3093600	Printer Data, Red Patch/Printer
1W79	A3093597	Printer Data, Red Patch/WS2
1W80	None	Power, Printer
1W81	A3093582	LGM Alarm, Red Patch/LGM
1W82	A3093597	Console Data, Red Patch/CP1
1W83	A3093597	Console Data, Red Patch/CP2
1W84	A3093597	Console Data, Red Patch/DBMP

CABLE REFERENCE DESIGNATOR TO DRAWING NUMBER INDEX - Continued

Reference Designator	Cable Assembly Drawing Number	Cable Function Name
1W86	A3093604	Console Data, Red Patch/WS1
1W87	A3093608	Data, Black Patch/LGM
1W88	A3093643	Power, LGM
1W89	A3093609	Data, Black Patch/GM
1W90	A3093609	Data, Black Patch/GM
1W91	A3093608	Data, Black Patch/GM
1W92	A3093608	Data, Black Patch/GM
1W95	A3093610	Data, Black Patch/GM
1W96	A3093611	Data, Black Patch/GM
1W97	A3093617	ROA Data, Black Patch/ROA
1W98	A3093610	Data, Black Patch/GM
1W99	A3093611	Data, Black Patch/GM
1W100	A3093617	ROA Data, Black Patch/ROA
1W101	A3093629	Data, Black Patch/SVEP
1W103	A3093638	Alarm Data, Red Patch/CP1
1W105	A3093643	Power, GM
1W106	A3093622	Group Data, Black Patch/SVEP
1W107	A3093622	Group Data, Black Patch/SVEP
1W108	A3093635	Group Data, Black Patch/SVEP
1W109	A3092673	Intercom Signal, Black Patch/Intercom
1W110	None	Power, CP1
1W114	A3093598	FOER Interface, FOER/ESTA
1W115	A3093598	FOER Interface, FOER/ESTA
1W116	A3093638	Alarm Data, Red Patch/CP2
1W120	None	Radio Data, J-3513/RT-524 (ANNRC-46)
1W121	None	Radio Data, J-3513/KY-57 (AN/VRC-46)
1W122	None	Power, KY-57, J-3513/HYP-57 (AN/VRC-46)
1W125	A3092668	Antenna Control, RT-524/AEP (AN/VRC-46)
1W126	A3093623	Radio Data, Red Patch/J-3513 (AN/VRC-46)
1W127	A3093639	Radio Data, Red Patch/KY-57 (AN/VRC-46)
		Radio Data, Red Patch/RT-1439 (AN/VRC-90)
1W128	A3093628	Radio Rf, RT-524/AEP (AN/VRC-46)
		Radio Rf, RT-1439/AEP (AN/VRC-90)
1W129	A3093645	Power, Radio, Dc Filter/MT-1029 (AN/VRC-46)
		Power, Radio, Dc Filter/MT-6352 (AN/VRC-90)
1W132	None	Radio Data, RT-1439/KY-57 (AN/VRC-90)
1W134	None	Power, KY-57, MT-6352/HYP-57 (ANNRC-90)
1W140	A3093628	Radio Rf, Antenna/AEP
1W141	A3093616.	Antenna Control, Antenna/AEP (AN/VRC-46)
1W401	A3093641	Alarm Data, ADP Red Patch/UPS Control Unit
1W506	A3093580	UPS Inverter A Line In, UPS Input/Inverter A
1W507	A3093580	UPS Inverter B Line In, UPS Input/Inverter B
1W508	A3093580	UPS Inverter C Line In, UPS Input/Inverter C

CABLE REFERENCE DESIGNATOR TO DRAWING NUMBER INDEX - Continued

Reference Designator	Cable Assembly Drawing Number	Cable Function Name
1W509	A3093580	UPS Inverter A Control, UPS Control/Inverter A
1W510	A3093580	UPS Inverter A Dc, UPS Control/Inverter A
1W511	A3093580	UPS Inverter A Out, UPS Control/Inverter A
1W512	A3093580	UPS Inverter B Control, UPS Control/Inverter B
1W513	A3093580	UPS Inverter B Dc, UPS Control/Inverter B
1W514	A3093580	UPS Inverter B Out, UPS Control/Inverter B
1W515	A3093580	UPS Inverter C Control, UPS Control/Inverter C
1W516	A3093580	UPS Inverter C Dc, UPS Control/Inverter C
1W517	A3093580	UPS Inverter C Out, UPS Control/Inverter C
1W518	A3093580	UPS Battery A Dc, UPS Control/Battery A
1W519	A3093580	UPS Battery B Dc, UPS Control/Battery B
1W520	A3093580	UPS Battery C Dc, UPS Control/Battery C
2W1	SC-D-883963	Power, ADP Shelter Prime Power, 50 Ft
2W2	SC-D-883964	Power, ADP Shelter Prime Power, 10 Ft Stub
2W3	SM-D-811235	Data, Telephone Cable Stub, 10 Ft
2W4	None	Fiber-Optic Cable, ADP/RTC
2W5	A3093642	Data, 26-Pair Cable, ADP/OPN, 50 Ft
2W6	A3093640	Data, 26-Pair Cable Extension, 50 Ft
2W7	SC-D-883963	Power, OPN Shelter Prime Input Power, 50 Ft
2W8	SC-D-883964	Power, OPN Shelter Prime Power, 10 Ft Stub
2W9	None	Fiber-Optic Cable, ADP/OPN
3A1W2	A3092669	Ethernet, RSA/ESTA
3A1W3	A3092719	Power, Filter/RSA
3A1W4	A3093625	FOER Interface, FOER/ESTA
3W1	A3093601	Fiber Optic, Transit Case/RSA FOER
3W2	A3093597	Printer Data, WS1/Printer
3W3	A3092669	Ethernet, WS1/WS2
3W4	A3092669	Ethernet, WS2/RSA
3W5	A3093089	Power, WS1
3W6	None	Power, Printer
3W7	A3093089	Power, WS2
3W8	A3093644	Power, RSA
4W1	A3093644	Power, RSA
4W2	A3093601	Fiber Optic, RSA/SEP
4W4	A3092669	Ethernet, RSA/WS1
4W5	A3093606	Data, Black Patch/DSVT 1
4W6	A3093635	Data, Black Patch/SEP
4W7	A3093620	Data, Telephone A12/DSVT 1
4W10	A3093620	Data, Telephone A13/DSVT 2
4W11	A3093606	Data, Black Patch/DSVT 2
4W13	A3092669	Ethernet, WS1/WS2
4W14	A3092669	Ethernet, WS2/WS3
4W15	A3092669	Ethernet, WS3/WS4

CABLE REFERENCE DESIGNATOR TO DRAWING NUMBER INDEX - Continued

Reference Designator	Cable Assembly Drawing Number	Cable Function Name
4W16	A3093597	Printer Data, Red Patch/WS1
4W17	A3093597	Printer Data, Red Patch/WS2
4W18	A3093089	Power, WS1
4W19	A3093600	Printer Data, Red Patch/Printer 1
4W20	A3093089	Power, WS2
4W21	A3093089	Power, WS3
4W22	A3093600	Printer Data, Red Patch/Printer 2
4W23	A3093089	Power, WS4
4W24	A3093620	Data, Telephone A20/DSVT 3
4W25	A3093606	Data, Black Patch/DSVT 3
4W27	A3093606	Data, Black Patch/DSVT 4
4W28	None	Power, Printer 2
4W29	A3093620	Data, Red Patch/DSVT 4
4W30	None	Power, Printer 1
4W31	A3093620	Data, Red Patch/Telephone A21
4W33	A3093621	Data, Red Patch/LDF
4W44	A3093597	Printer Data, Red Patch/WS3
4W45	A3093597	Printer Data, Red Patch/WS4
4W49	A3092673	Intercom, Red Patch/Intercom
4W50	A3093629	Data, Black Patch/SEP
4W120	None	Radio Data, J-3513/RT-524 (AN/VRC-46)
4W121	None	Radio Data, J-3513/KY-57 (AN/VRC-46)
4W122	None	Power, KY-57, J-3513/HYP-57 (AN/VRC-46)
4W125	A3092668	Antenna Control, RT-524/AEP (AN/VRC-46)
4W126	A3093623	Radio Data, Red Patch/J-3513 (ANNRC-46)
4W127	A3093639	Radio Data, Red Patch/KY-57 (ANNRC-46)
		Radio Data, Red Patch/RT-1439 (ANNRC-90)
4W128	A3093628	Radio Rf, RT-524/AEP (ANNRC-46)
		Radio Rf, RT-1439/AEP (AN/VRC-90)
4W129	A3093645	Power, Radio, Dc Filter/MT-1029 (AN/VRC-46)
		Power, Radio, Dc Filter/MT-6352 (AN/VRC-90)
4W132	None	Radio Data, RT-1439/KY-57 (ANNRC-90)
4W134	None	Power, KY-57, MT-6352/HYP-57 (AN/VRC-90)
4W140	A3093628	Radio Rf, Antenna/AEP
4W141	A3093616	Antenna Control, Antenna/AEP (ANNRC-46)
4W506	A3093580	UPS Inverter A Line In, UPS Input/Inverter A
4W507	A3093580	UPS Inverter B Line In, UPS Input/Inverter B
4W508	A3093580	UPS Inverter C Line In, UPS Input/Inverter C
4W509	A3093580	UPS Inverter A Control, UPS Control/Inverter A
4W510	A3093580	UPS Inverter A Dc, UPS Control/Inverter A
4W511	A3093580	UPS Inverter A Out, UPS Control/Inverter A
4W512	A3093580	UPS Inverter B Control, UPS Control/Inverter B
4W513	A3093580	UPS Inverter B Dc, UPS Control/Inverter B

CABLE REFERENCE DESIGNATOR TO DRAWING NUMBER INDEX - Continued

Reference Designator	Cable Assembly Drawing Number	Cable Function Name
4W514	A3093580	UPS Inverter B Out, UPS Control/Inverter B
4W515	A3093580	UPS Inverter C Control, UPS Control/Inverter C
4W516	A3093580	UPS Inverter C Dc, UPS Control/Inverter C
4W517	A3093580	UPS Inverter C Out, UPS Control/Inverter C
4W518	A3093580	UPS Battery A Dc, UPS Control/Battery A
4W519	A3093580	UPS Battery B Dc, UPS Control/Battery B
4W520	A3093580	UPS Battery C Dc, UPS Control/Battery C

CABLE NAME TO DRAWING NUMBER INDEX

This cross-reference lists the cable functional names (Cable Name) of all AN/TYQ-30(V)1/2 cables, in alphabetical sequence. For each listed cable, the cable assembly drawing number and all applicable reference designators are provided. The cable assembly drawing is the drawing that provides information required to repair the cable.

Cable Functional Name	Cable Assembly Drawing Number	Reference Designator
ADP Shelter/TTC-39, 10-Ft Telephone Cable Stub	SM-D-811235	2W3
ADP Shelter/OPN Shelter, Fiber-Optic Cable	None	2W9
ADP Shelter/OPN Shelter, 26-Pair Cable, 50 Ft	A3093642	2W5
ADP Shelter/OPN Shelter, 26-Pair Cable Extension	A3093640	2W6
ADP Shelter/Prime Power, 50-Ft Cable	SC-D-883963	2W1
ADP Shelter/Prime Power, 10-Ft Stub	SC-D-883964	2W2
ADP Shelter/RTC, Fiber-Optic Cable	None	2W4
AEP/Antenna, Control	A3093616	1W141 4W141
AEP/Antenna, Rf	A3093628	1W140 4W140
AEP/RT-524, Control (AN/VRC-46)	A3092668	1W125 4W125
AEP/RT, Rf	A3093628	1W128 4W128
Black Patch/DSVT	A3093606	1W7 1W11 1W18 1W26 1W38 1W43 1W49 1W56 1W65 1W75 4W5 4W11 4W25 4W27
Black Patch/GM	A3093609	1W89 1W90
Black Patch/GM	A3093608	1W91 1W92
Black Patch/GM	A3093610	1W95 1W98
Black Patch/GM	A3093611	1W96 1W99

CABLE NAME TO DRAWING NUMBER INDEX - Continued

Cable Functional Name	Cable Assembly Drawing Number	Reference Designator
Black Patch/Intercom, Intercom Signal	A3092673	1W109 4W49
Black Patch/LGM, GM Data 1W12	A3093607	1W8
Black Patch/LGM, Group Data	A3093608	1W87
Black Patch/ROA	A3093617	1W97 1W100
Black Patch/SEP, Data	A3093635	4W6
Black Patch/SEP, Intercom	A3093629	4W50
Black Patch/SVEP, Intercom	A3093535	1W108
Dc Filter/MT-6352 (AN/VTC-90)	A3093645	1W129 4W129
Dc Filter/MT-1029 (AN/VRC-46)	A3093645	1W129 4W129
DSDI/DSVT, Data	A3093605	1W6 1W10 1W17 1W25 1W37 1W42 1W48 1W55
DSDI/Power	A3093644	1W9 1W16 1W22 1W31 1W41 1W44 1W53 1W60
ESTA/ESTA, Ethernet	A3092669	1W2 1W4 1W19 1W34
ESTA/FOER, FOER Interface	A3093625	3A1W4
ESTA/Transit Case, Ethernet	A3092669	3A1W2
ESTA/FOER, FOER Interface	A3093598	1W114 1W115
ESTA/Workstation, Ethernet	A3092669	1W46
FOER/Filter, Power	A3092719	3A1W3
FOER/FOEP, Fiber-Optic	A3093601	1W3 1W5

CABLE NAME TO DRAWING NUMBER INDEX - Continued

Cable Functional Name	Cable Assembly Drawing Number	Reference Designator
FOER/RSA Transit Case, Fiber-Optic	A3093601	3W1
FOER/Power	None	1W1 1W13
GM/Power	A34093643	1W105
HYP-57/J-3513 (AN/VRC-46)	None	1W122
HYP-57/MT-6352 (ANNRC-90)	None	1W134 4W134
KY-57/J-3513 (AN/VRC-46)	None	1W121
KY-57/RT-1439 (AN/VRC-90)	None	1W132 4W132
LGM/Power	A3093643	1W88
OPN Shelter/Prime Power, 50-Ft Cable	SC-D-883963	2W7
OPN Shelter/Prime Power, 10-Ft Stub	SC-D-883964	2W8
Printer/Power	None	1W80 3W6 4W28 4W30
Processor/Power None		1W63 1W68 1W110
Red Patch/CP, Alarms	A3093638	1W103 1W116
Red Patch/CP, Data Channel	A3093599	1W14 1W20 1W23 1W27 1W29 1W32 1W35 1W39 1W45 1W57 1W50 1W52 1W54 1W57 1W59
Red Patch/DSDI	A3093602	1W61 1W15 1W21 1W24 1W28 1W30

CABLE NAME TO DRAWING NUMBER INDEX - Continued

Cable Functional Name	Cable Assembly Drawing Number	Reference Designator
Red Patch/DSVT, Data	A3093620	1W33 1W36 1W40 1W74
Red Patch/GM, Alarms	A3093646	4W29 1W76
Red Patch/J-3513 (ANNRC-46)	A3093623	1W126 4W126
Red Patch/KY-57 (ANNRC-46)	A3093639	1W127 4W127
Red Patch/LDF, Data	A3093621	1W58 4W33
Red Patch/LGM, Alarms	A3093582	1W81
Red Patch/Printer, Printer Data	A3093600	1W78 4W19 4W22
Red Patch/Processor, Console	A3093597	1W82 1W83 1W84
Red Patch/RT-1439 (AN/VRC-90)	A3093639	1W127 4W127
Red Patch/Telephone, Data	A3093620	1W70 4W31
Red Patch/UPS Control, Alarms	A3093641	1W401
Red Patch/WS, Console	A3093604	1W86
Red Patch/WS, Printer Data	A3093597	1W77 1W79 4W16 4W17 4W44 4W45
RSA/Power	A3093644	3W8 4W1
RSA/SEP Fiber-Optic	A3093601	4W2
RSA/Workstation, Ethernet	A3092669	4W4
RT-524/J-3513 (AN/VRC-46)	None	1W120
Telephone/DSVT, Data	A3093620	1W64 4W7 4W10 4W24
UPS Control/Battery, Battery Dc	A3093580	1W518 1W519 1W520

CABLE NAME TO DRAWING NUMBER INDEX - Continued

DRAWINGS

Cable Functional Name	Cable Assembly Drawing Number	Reference Designator
UPS Control/Inverter, Control	A3093580	4W518 4W519 4W520 1W509 1W512 1W515 4W509 4W512 4W515
UPS Control/Inverter, Ac Out	A3093580	1W511 1W514 1W517 4W511 4W514 4W517
UPS Control/Inverter, Inverter Dc	A3093580	1W510 1W513 1W516 4W510 4W513 4W516
UPS Input/Inverter, AC In	A3093580	1W506 1W507 1W508 4W506 4W507 4W508
Workstation/Power	A3093089	1W72 1W73 3W5 3W7 4W18 4W20 4W21 4W23
Workstation/Printer, Printer Data	A3093597	3W2
Workstation/RSA, Ethernet	A3092669	3W4
Workstation/Workstation, Ethernet	A3092669	1W51 3W3 4W13 4W14 4W15

The remaining pages in TM 11-5895-1392-34-2 are the wiring and interconnect drawings. These drawings include schematic diagrams, wiring diagrams, assembly drawings, and point-to-point wire lists. Each drawing has a drawing number (A309xxxx). Many of these drawings consist of more than one sheet (page). Each sheet of each multiple sheet drawing has a sheet number in addition to the drawing number. The schematic, wiring, and assembly drawings are 11 by 17 inch pages. The wire list sheets are shown as two sheets per page. The 11 by 17 inch pages are printed on one side only and appear as all right-hand pages. All drawings are arranged in drawing number (A309xxxx) and sheet number sequence.

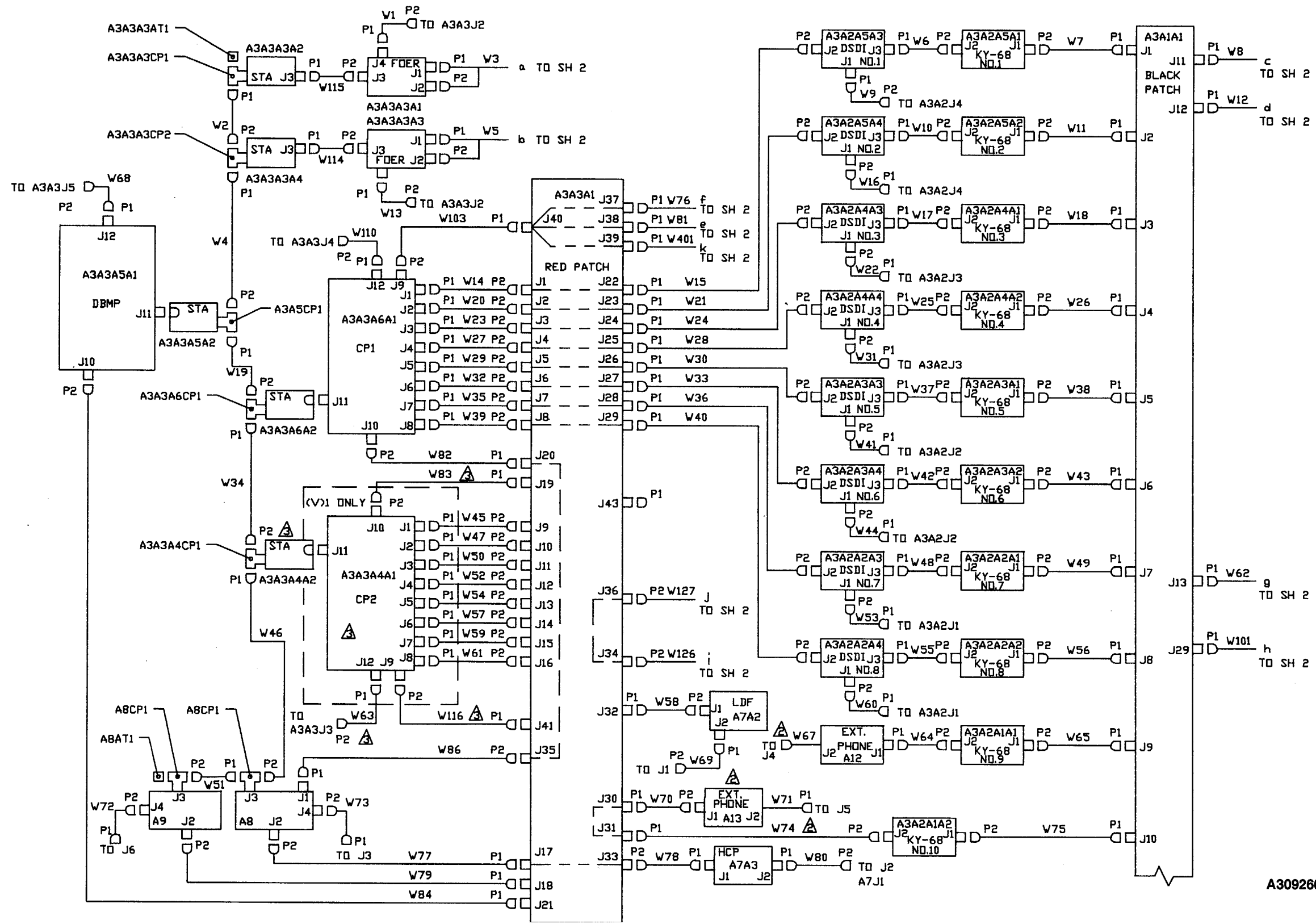

A3092660

Interconnection Diagram, ADP System - AN/TYQ-30 (Sheet 1 of 2)

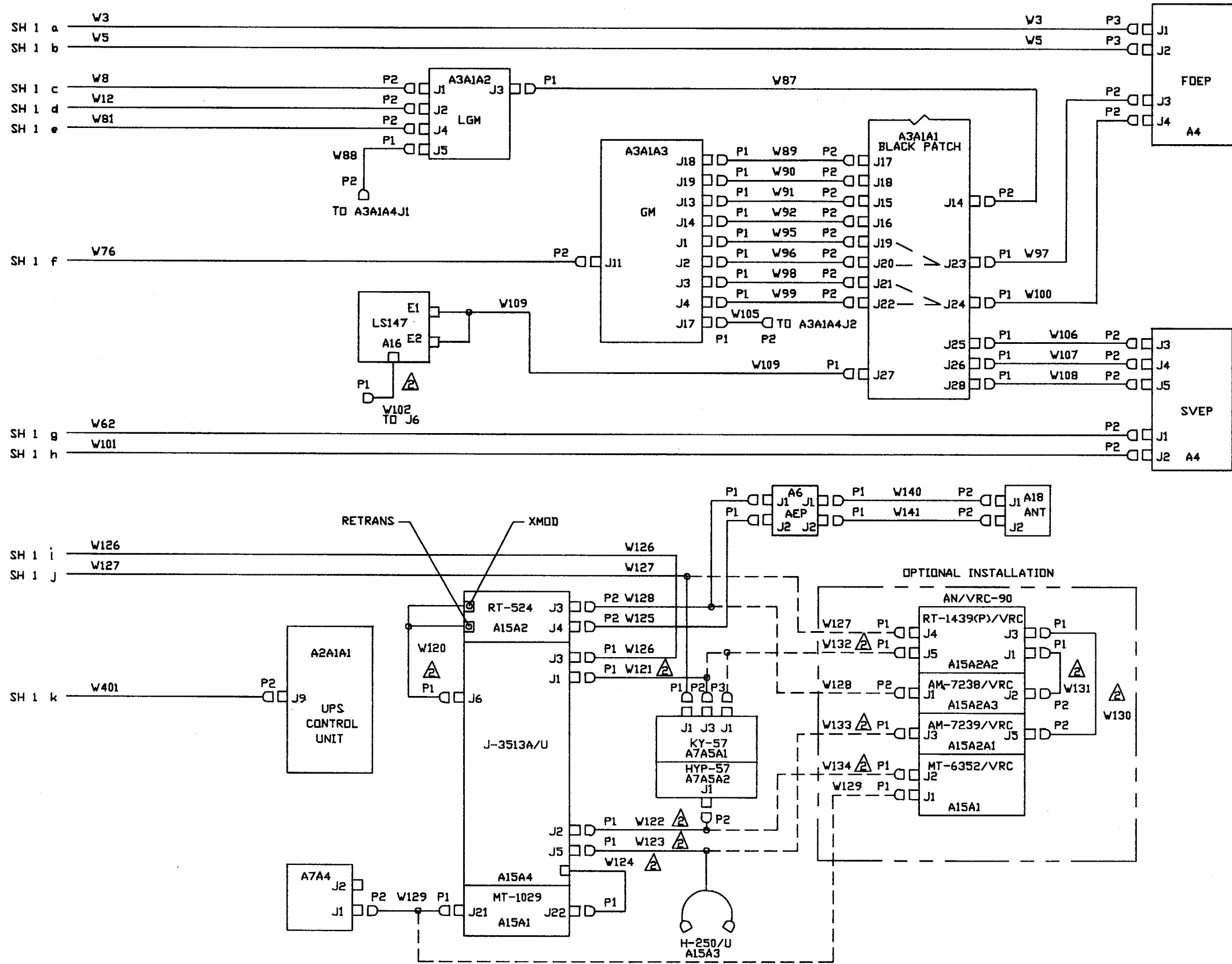

Interconnection Diagram, ADP System - AN/TYQ-30 (Sheet 2 of 2)

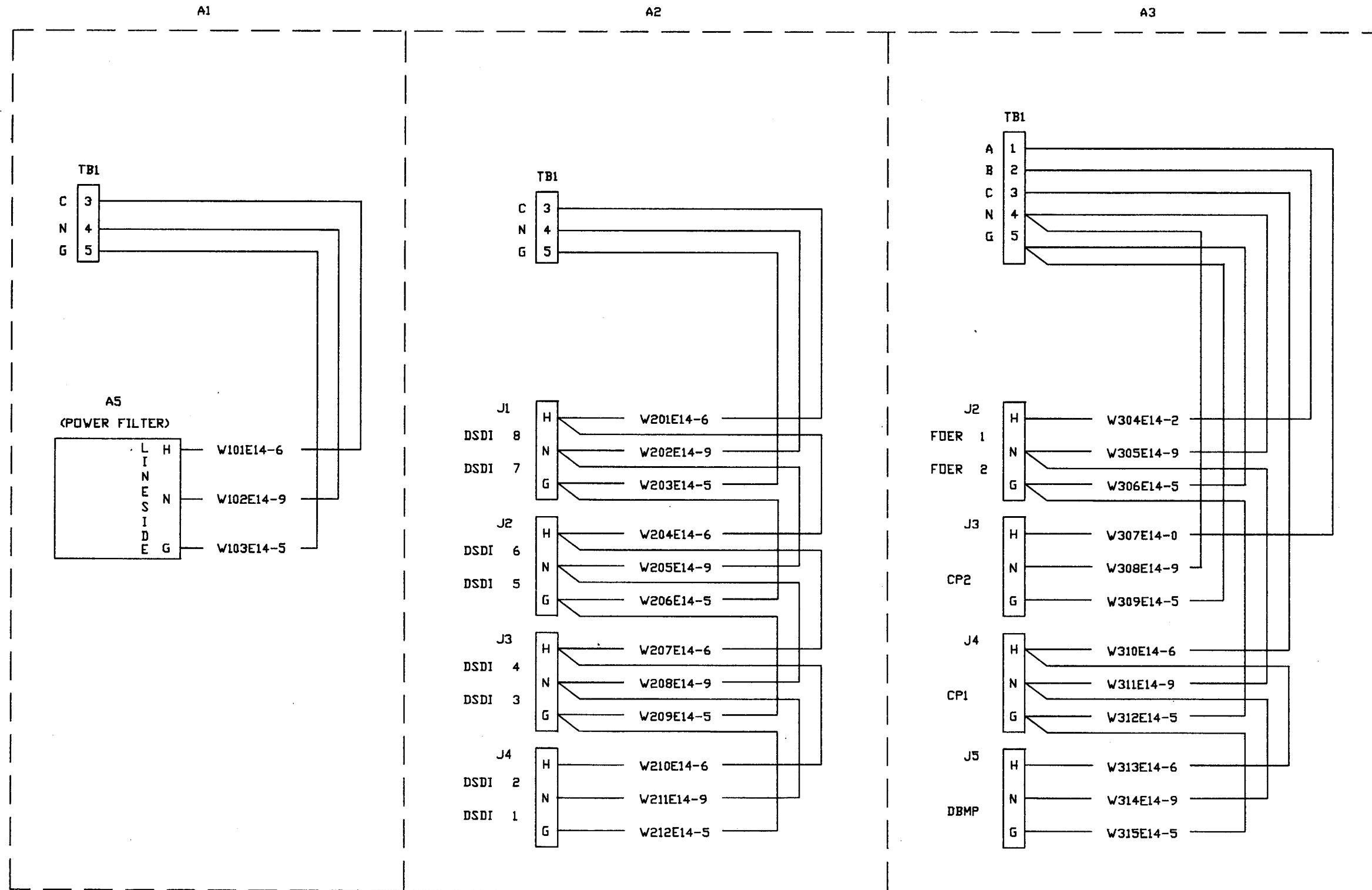

NOTE : PARTIAL REFERENCE DESIGNATION ARE SHOWN, FOR COMPLETE REFERENCE DESIGNATION, PREFIX WITH UNIT NUMBER AND SUB ASSEMBLY DESIGNATION,

Schematic Diagram, Power Distribution-Data Racks-AN/TYQ-30

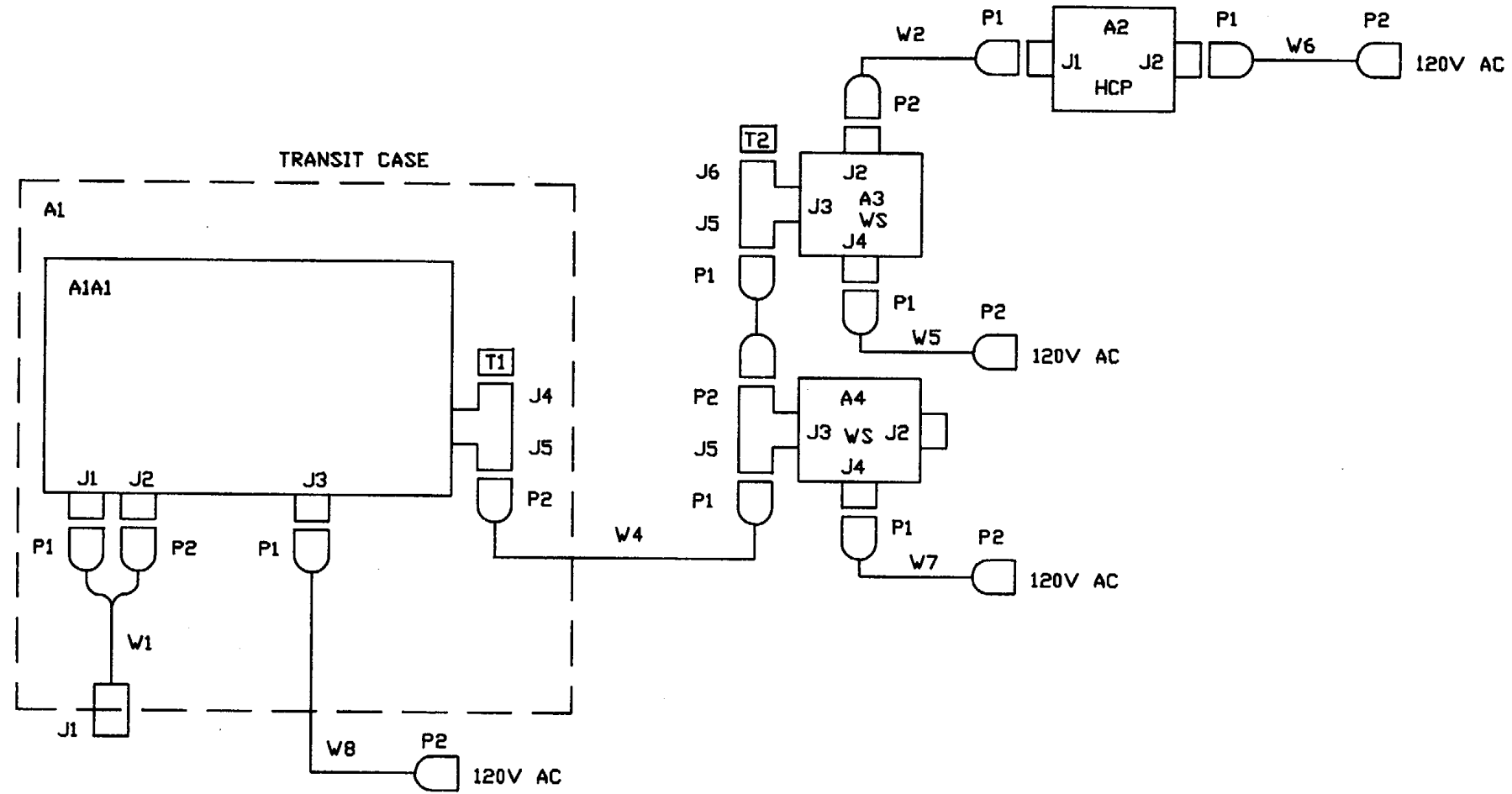

NOTE

PARTIAL REFERENCE DESIGNATIONS ARE SHOWN. COMPLETE REFERENCE DESIGNATION, PREFIX WITH UNIT NUMBER AND SUB ASSEMBLY DESIGNATION.

Interconnection Diagram, Remote Terminal Cluster

NOTES :

1. IDENTIFY PART PER MIL-STD-130, TAG.
2. WORKMANSHIP SHALL BE IN ACCORDANCE WITH MIL-STD-454, REQUIREMENT 9.
3. DIMENSIONAL DATA IS BASED ON AMERICAN NATIONAL STANDARD ANSI Y14.5-1973.
4. CRIMP INSERTION TOOL NO. M81969/17-03, REMOVAL TOOL NO. M81969/19-07, PER MIL-1-81969.
5. CRIMPING TOOL NO. M22520/2-01 WITH M22520/2-09 TURRET, PER MIL-C-22520.
6. EACH CONDUCTOR SHALL BE TESTED FOR CONTINUITY AND CORRECT CONNECTIONS BETWEEN ITS TERMINATIONS, USING A POTENTIAL OF NOT MORE THAN 10 VOLTS. CONTINUITY CHECKS SHALL BE MADE FROM CONNECTOR CONTACT TO CONNECTOR CONTACT USING A CONTINUITY TESTER. CONTINUITY POINTS SHALL BE OBTAINED FROM THE CABLE WIRING DIAGRAM. WHERE SHIELD IS BONDED TO CONNECTOR ON BOTH ENDS, THE SHIELD CONTINUITY SHALL BE CHECKED FROM CONNECTOR SHELL TO CONNECTOR SHELL.
7. INSULATION RESISTANCE SHALL BE IN ACCORDANCE WITH METHOD 302 OF MIL-STD-202, TEST CONDITION B. THE POTENTIAL SHALL BE APPLIED BETWEEN EACH CONDUCTOR AND THE REMAINING CONDUCTORS CONNECTED TOGETHER AND TO THE SHIELD, AND CONNECTOR. THE INSULATION RESISTANCE OF THE CABLE ASSEMBLY SHALL NOT BE LESS THAN 100 MEGOHMS. EXCEPT THE INSULATION RESISTANCE OF A SHIELDED CONDUCTOR SHALL NOT BE LESS THAN 30 MEGOHMS.
8. DIELECTRIC WITHSTAND VOLTAGE. DIELECTRIC STRENGTH SHALL BE PERFORMED IN ACCORDANCE WITH METHOD 301 OF MIL-STD-202. A POTENTIAL OF 500 VOLTS DC SHALL BE APPLIED FOR 30 SECONDS MINIMUM. THE POTENTIAL SHALL BE APPLIED BETWEEN EACH CONDUCTOR AND THE REMAINING CONDUCTORS CONNECTED TOGETHER AND TO THE SHIELD AND CONNECTOR.
9. PARTIAL REFERENCE DESIGNATION ARE SHOWN. FOR COMPLETE REFERENCE DESIGNATION, PREFIX WITH UNIT NUMBER AND SUBASSEMBLY DESIGNATION.
10. SOLDERING SHALL BE IN ACCORDANCE WITH MIL-STD-454, REQUIREMENT 5.

THIS NOTE INTENTIONALLY LEFT BLANK.

- THIS NOTE INTENTIONALLY LEFT BLANK.
- THIS NOTE INTENTIONALLY LEFT BLANK.
- ALL SHIELDS MUST TERMINATE INSIDE OF EMI BACKSHELL.
- QUANTITY SHOWN IS IN INCHES.
- TOLERANCE ON CABLE LENGTH SHALL BE +2, -1 INCHES.
- COMPLETE PART NUMBER FOR THIS ASSEMBLY SHALL INCLUDE APPLICABLE DASH NUMBER INDICATED IN QUANTITY REQUIRED COLUMN.
- VENDOR ITEM -SEE SPECIFICATION CONTROL DRAWING.
- DIMENSIONS SHOWN ON CABLE PREPARATION ILLUSTRATION ARE FOR REFERENCE ONLY.

1	1	14	80058	U-39-U	CONNECTOR, ELECTRICAL, PLUG	MIL-C-55116		
		13		MS27468T11B35P				
1	1	12	96906		CONNECTOR, ELECTRICAL, PLUG			
		11		M39029/58-360				
13	13	10	81349		CONTACT, CRIMP, PIN	MIL-C-39029/58		
		9						
		8						
		7						
		6						
REF	REF	5	80063	A3092728	TEST PROCEDURE/DATA SHEET POWER AND SIGNAL CABLE TEST			
1	1	4	80063	A3093589-57	BACKSHELL, EMI/RFI			18
		3						
230	270	2	80063	A3093562-9	CABLE, ELECTRICAL, SPECIAL PURPOSE			15 , 18
1	1	1	80063		BACKSHELL, EMI/RFI			18
QTY REQD	QTY REQD	FIND NO.	FSCM NO.	A3093479-1	NOMENCLATURE OR DESCRIPTION	SPEC/STD	SHEET NO.	NOTE
				PART NUMBER OR				
-2	-1			PARTS LIST				

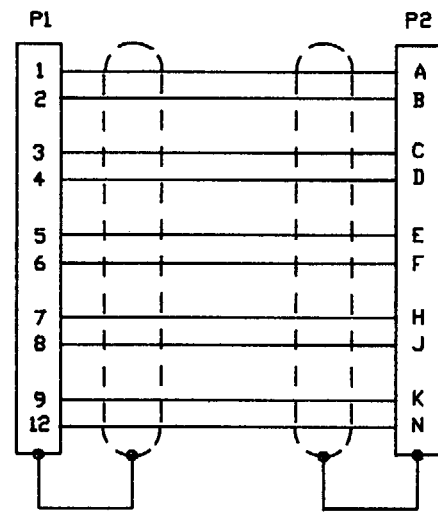

WIRING DIAGRAM

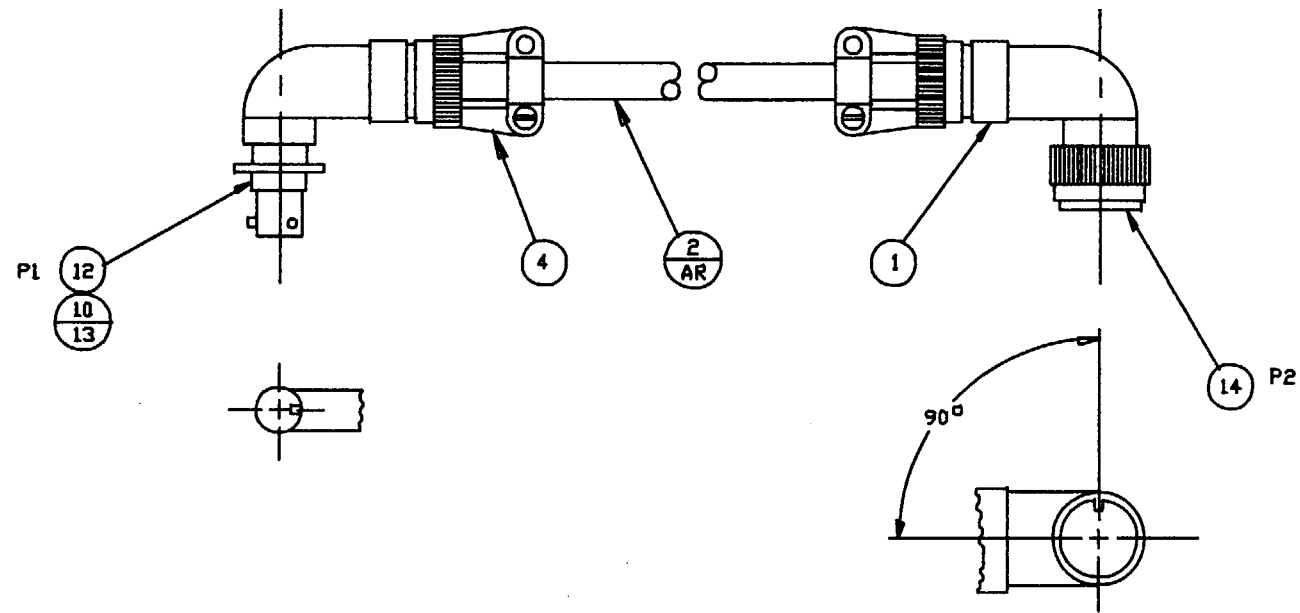
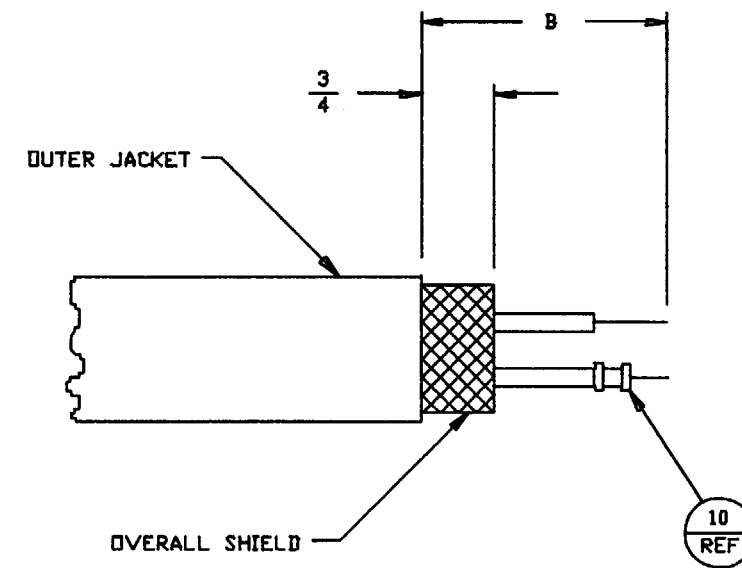

CHART A	
DASH NO.	DIM A
1	270.00
2	230.00

CHART B	
END TYPE	DIM B
P1	1.25 REF
P2	2.75 REF



△14 △19 CABLE PREPARATION

SCALE : NONE
BOTH ENDS

NOTES :

1. IDENTIFY PART PER MIL-STD-130, TAG.
2. WORKMANSHIP SHALL BE IN ACCORDANCE WITH MIL-STD-454, REQUIREMENT 9.
3. DIMENSIONAL DATA IS BASED ON AMERICAN NATIONAL STANDARD ANSI Y14.5-1973.
4. EACH CONDUCTOR SHALL BE TESTED FOR CONTINUITY AND CORRECT CONNECTIONS BETWEEN ITS TERMINATIONS, USING A POTENTIAL OF NOT MORE THAN 10 VOLTS. CONTINUITY CHECKS SHALL BE MADE FROM CONNECTOR CONTACT TO CONNECTOR CONTACT USING A CONTINUITY TESTER. CONTINUITY POINTS SHALL BE OBTAINED FROM THE CABLE WIRING DIAGRAM. WHERE SHIELD IS BONDED TO CONNECTOR ON BOTH ENDS, THE SHIELD CONTINUITY SHALL BE CHECKED FROM CONNECTOR SHELL TO CONNECTOR SHELL.
5. INSULATION RESISTANCE SHALL BE IN ACCORDANCE WITH METHOD 302 OF MIL-STD-202, TEST CONDITION B. THE POTENTIAL SHALL BE APPLIED BETWEEN EACH CONDUCTOR AND THE REMAINING CONDUCTORS CONNECTED TOGETHER AND TO THE SHIELD, AND CONNECTOR. THE INSULATION RESISTANCE OF THE CABLE ASSEMBLY SHALL NOT BE LESS THAN 100 MEGOHMS, EXCEPT THE INSULATION RESISTANCE OF A SHIELDED CONDUCTOR SHALL NOT BE LESS THAN 30 MEGOHMS.
6. DIELECTRIC WITH STANDING VOLTAGE. DIELECTRIC STRENGTH SHALL BE PERFORMED IN ACCORDANCE WITH METHOD 301 OF MIL-STD-202. A POTENTIAL OF 500 VOLTS DC SHALL BE APPLIED FOR 30 SECONDS MINIMUM. THE POTENTIAL SHALL BE APPLIED BETWEEN EACH CONDUCTOR AND THE REMAINING CONDUCTORS CONNECTED TOGETHER AND TO THE SHIELD AND CONNECTOR.
7. PARTIAL REFERENCE DESIGNATION ARE SHOWN. FOR COMPLETE REFERENCE DESIGNATION, PREFIX WITH UNIT NUMBER AND SUBASSEMBLY DESIGNATION.
8. SOLDERING SHALL BE IN ACCORDANCE WITH MIL-STD-454, REQUIREMENT 5.

9. QUANTITY SHOWN IS IN INCHES.

10. TOLERANCE ON CABLE LENGTH SHALL BE +2,-1 INCHES.

11. DIMENSIONS SHOWN ON CABLE PREPARATION ILLUSTRATION ARE FOR REFERENCE ONLY.

12. VENDOR ITEM, SEE SPECIFICATION CONTROL DRAWING.

13. CRIMPING TOOL NO. M22520/5-01 WITH Y613 DIE, PER MIL-C-22520.

14. COMPLETE PART NUMBER FOR THIS ASSEMBLY SHALL INCLUDE APPLICABLE DASH NUMBER INDICATED IN QUANTITY REQUIRED COLUMN.

PARTS STATUS	
DASH NO.	REV. LTR.
1	B
2	B
3	B
4	D
5	B
6	B
7	C
8	D
9	D
10	D

REF	REF	REF	REF	REF	REF	REF	REF	REF	REF	6	80063	A3092728	TEST PROCEDURE/DATA SHEET POWER AND SIGNAL CABLE TEST				
248	200	176	12	427	406	122	104	70	28	5	80063	A3093535	CABLE, COAX, TRIAX				9,12
										4							
										3							
										2							
2	2	2	2	2	2	2	2	2	2	1	80063	A3092916	CONNECTOR, RF, TRIAX				12
QTY REQD	QTY REQD	QTY REQD	QTY REQD	QTY REQD	QTY REQD	QTY REQD	QTY REQD	QTY REQD	QTY REQD	FIND NO.	FSCM NO.	PART NUMBER OR	NOMENCLATURE OR DESCRIPTION	SPEC/STD	SHEET NO.	NOTE	
-10	-9	-8	-7	-6	-5	-4	-3	-2	-1								PARTS LIST

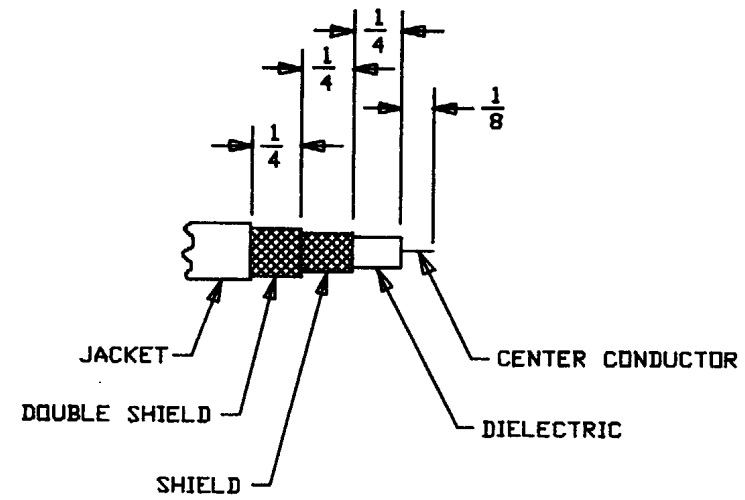
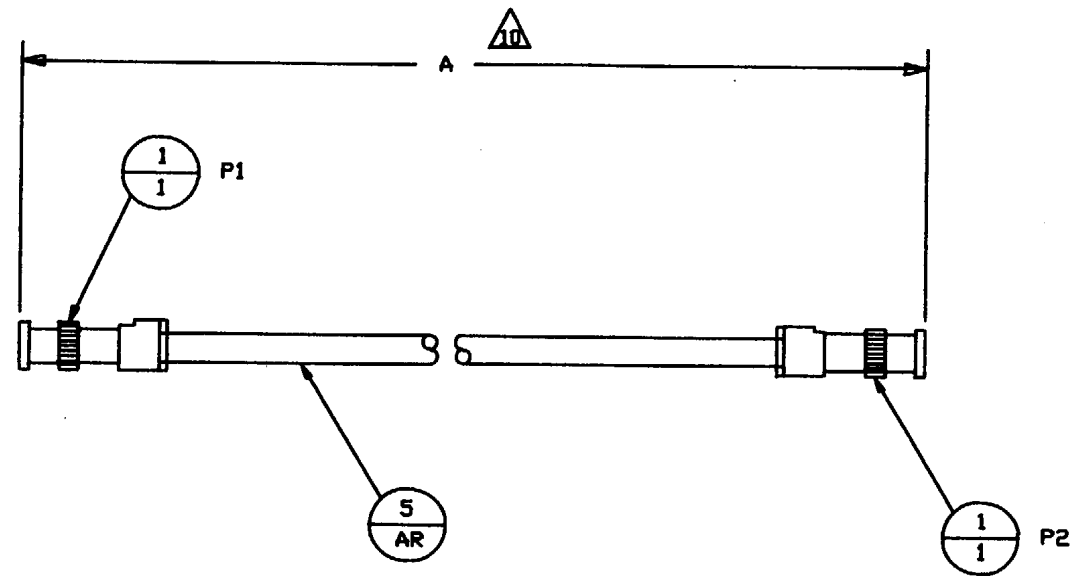

△ CABLE PREPARATION

BOTH ENDS

10	A3093637	DLA3092692	1	1
9	A3093637	DLA3092692	1	1
8	A3093637	DLA3092692	1	1
7	A3093476	DLA3092780	1	1
6	A3093632	DLA3092961	1	1
5	A3093571	DLA3105807	2	2
5	A3093630	DLA3092661	1	1
5	A3093630	DLA3092811	1	1
4	A3093630	DLA3092811	2	2
4	A3093630	DLA3092661	2	2
3	A3093631	DLA3092775	1	1
3	A3093630	DLA3092811	1	1
DASH	NEXT ASSEMBLY	USED ON	NEXT ASSY	FINAL ASSY
APPLICATION			QTY REQD	

CHART A	
DASH	DIM A
1	28.00
2	70.00
3	104.00
4	122.00
5	406.00
6	427.00
7	12.00
8	176.00
9	200.00
10	248.00

NOTES:

1. IDENTIFY PART PER MIL-STD-130, TAG.
2. WORKMANSHIP SHALL BE IN ACCORDANCE WITH MIL-STD-454, REQUIREMENT 9.
3. DIMENSIONAL DATA IS BASED ON AMERICAN NATIONAL STANDARD ANSI Y145-1973.
4. CRIMP INSERTION TOOL NO. M81969/8-07, REMOVAL TOOL NO. M81969/8-08, PER MIL-I-81969.
5. CRIMPING TOOL NO. M22520/1-02 WITH M22520/1-04BL TURRET, PER MIL-C-22520.
6. EACH CONDUCTOR SHALL BE TESTED FOR CONTINUITY AND CORRECT CONNECTIONS BETWEEN ITS TERMINATIONS, USING A POTENTIAL OF NOT MORE THAN 10 VOLTS. CONTINUITY CHECKS SHALL BE MADE FROM CONNECTOR CONTACT TO CONNECTOR CONTACT USING A CONTINUITY TESTER. CONTINUITY POINTS SHALL BE OBTAINED FROM THE CABLE WIRING DIAGRAM. WHERE SHIELD IS BONDED TO CONNECTOR ON BOTH ENDS, THE SHIELD CONTINUITY SHALL BE CHECKED FROM CONNECTOR SHELL TO CONNECTOR SHELL.
7. INSULATION RESISTANCE SHALL BE IN ACCORDANCE WITH METHOD 302 OF MIL-STD-202Z TEST CONDITION B. THE POTENTIAL SHALL BE APPLIED BETWEEN EACH CONDUCTOR AND THE REMAINING CONDUCTORS CONNECTED TOGETHER AND TO THE SHIELD, AND CONNECTOR. THE INSULATION RESISTANCE OF THE CABLE ASSEMBLY SHALL NOT BE LESS THAN 100 MEGOHMS. EXCEPT THE INSULATION RESISTANCE OF A SHIELDED CONDUCTOR SHALL NOT BE LESS THAN 30 MEGOHMS.
8. DIELECTRIC WITHSTAND VOLTAGE. DIELECTRIC STRENGTH SHALL BE PERFORMED IN ACCORDANCE WITH METHOD 301 OF MIL-STD-202, A POTENTIAL OF 500 VOLTS DC SHALL BE APPLIED FOR 30 SECONDS MINIMUM. THE POTENTIAL SHALL BE APPLIED BETWEEN EACH CONDUCTOR AND THE REMAINING CONDUCTORS CONNECTED TOGETHER AND TO THE SHIELD AND CONNECTOR.
9. PARTIAL REFERENCE DESIGNATION ARE SHOWN. FOR COMPLETE REFERENCE DESIGNATION, PREFIX WITH UNIT NUMBER AND SUBASSEMBLY DESIGNATION.
10. SOLDERING SHALL BE IN ACCORDANCE WITH MIL-STD-454, REQUIREMENT 5.

12. COMPLETE PART NUMBER FOR THIS ASSEMBLY SHALL INCLUDE APPLICABLE DASH NUMBER INDICATED IN QUANTITY REQUIRED COLUMN.
13. QUANTITY SHOWN IS IN INCHES.
14. TOLERANCE ON CABLE LENGTH SHALL BE +2,-1 INCHES.
15. WIRE ENDS ARE TO BE TINNED PER MIL-STD-454, REQUIREMENT 5.
16. CUT LENGTH TO 1 1/2 INCHES +1/2 -0 TOLERANCE.
17. DIMENSIONS SHOWN ON CABLE PREPARATION ILLUSTRATION ARE FOR REFERENCE ONLY.
18. VENDOR ITEM-SEE SPECIFICATION CONTROL DRAWING.



ALL UNUSED POSITIONS IN CONNECTOR P1 & P2 ARE TO BE FILLED WITH CONTACTS.

QTY REQD	QTY REQD	FIND NO.	FSCM NO.	PART NUMBER OR IDENTIFYING NO.	NOMENCLATURE OR DESCRIPTION	SPEC/STD	SHEET NO.	NOTE
		15						
3	3	14	81349	M39029/56-351	CONTACT, CRIMP, SOCKET	MIL-C-39029/56		
1	1	13	81349	M23053/4-202	INSULATION, SLEEVING	MIL-I-23053/4		16
		12						
1	1	11	96906	MS27467T9B98S	CONNECTOR, ELECTRICAL, PLUG			
		10						
		9						
		8						
		7						
		6						
REF	REF	5	80063	A3092728	TEST PROCEDURE/DATA SHEET POWER AND SIGNAL CABLE TEST			
		4						
1	1	3	80063	A3093589-69	BACKSHELL, EMI/RFI			18
		2						
348	224	1	80063	A3093563-2	CABLE, ELECTRICAL, SPECIAL PURPOSE			18
QTY REQD	QTY REQD	FIND NO.	FSCM NO.	PART NUMBER OR IDENTIFYING NO.	NOMENCLATURE OR DESCRIPTION	SPEC/STD	SHEET NO.	NOTE
PARTS LIST								

A3092673

Cable Assembly, LS147/Patch (Sheet 1 of 2)

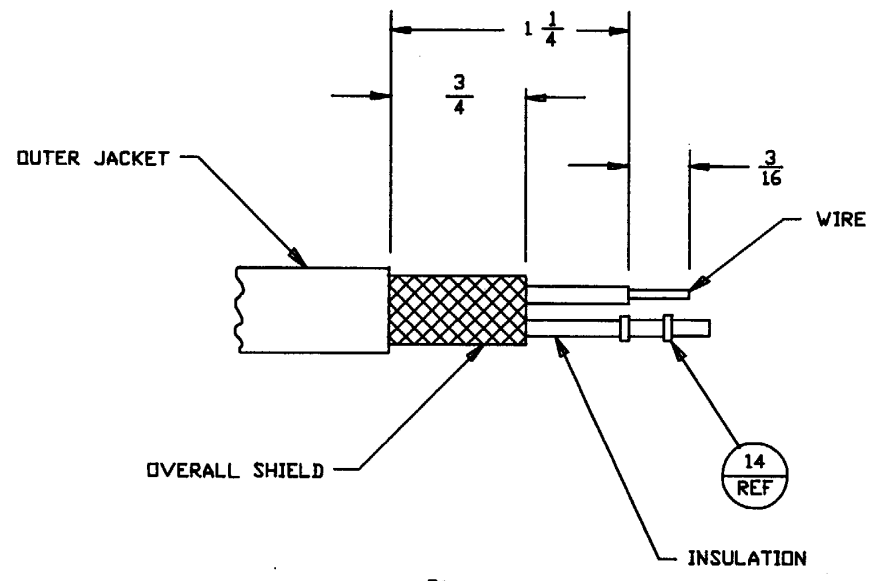
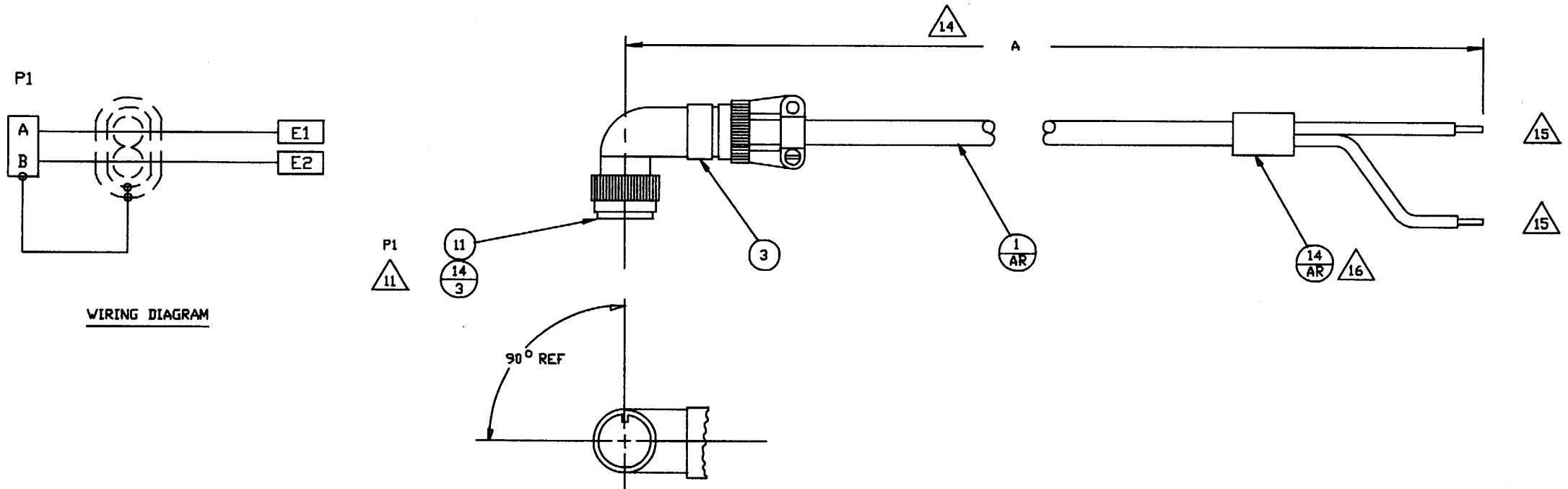

P1
CABLE PREPARATION
SCALE : NONE

17

15

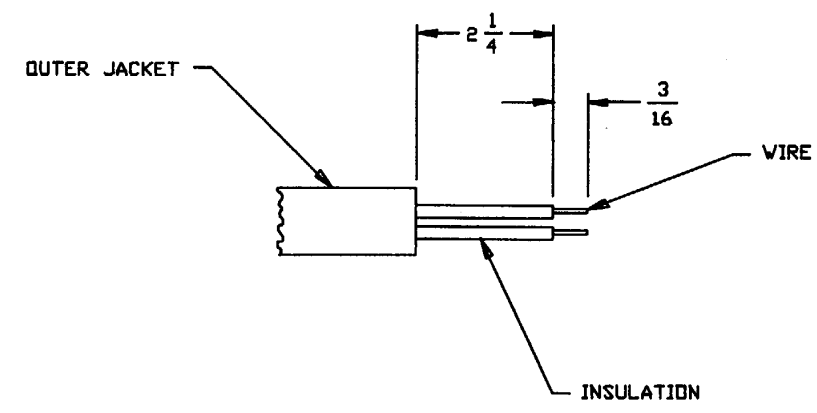

P2
CABLE PREPARATION
SCALE : NONE

17

15

CHART A	
DASH ND.	DIM A
1	224.00
2	348.00

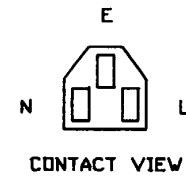
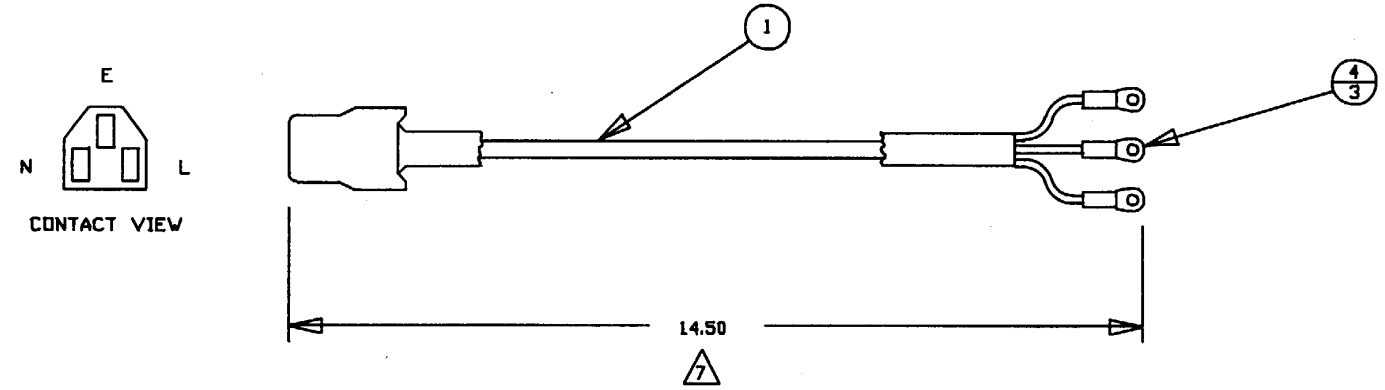

NOTES :

1. IDENTIFY PART PER MIL-STD-130, TAG.
 2. WORKMANSHIP IN ACCORDANCE WITH MIL-STD-454, REQUIREMENT 9.
 3. DIMENSIONAL DATA IS BASED ON AMERICAN NATIONAL STANDARD ANSI Y14.5-1973.
 4. CRIMPING TOOL, AMP NUMBER 59824-4.
 5. PARTIAL REFERENCE DESIGNATIONS ARE SHOWN. FOR COMPLETE REFERENCE DESIGNATION, PREFIX WITH UNIT NUMBER AND SUBASSEMBLY DESIGNATION.
 6. VENDOR ITEM -SEE SPECIFICATION CONTROL DRAWING.
- \triangle TOLERANCE ON CABLE LENGTH SHALL BE +2, -1 INCHES.

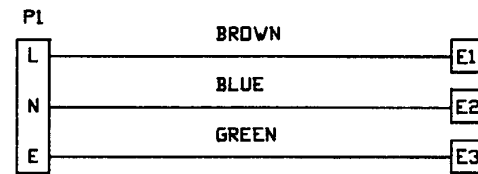

WIRING DIAGRAM

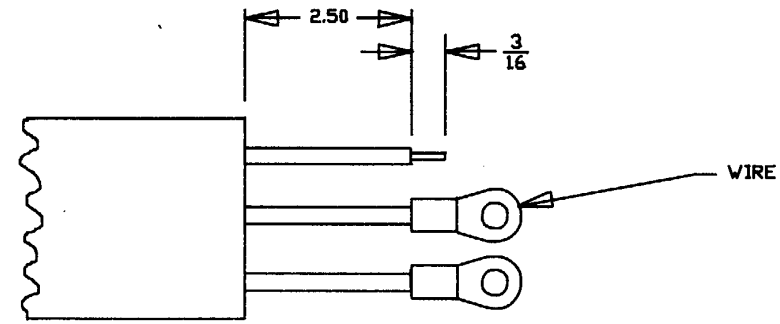

CABLE PREPARATION

SCALE : 2/1

QTY REQD	FIND NO.	FSCM NO.	PART NUMBER OR IDENTIFYING NO.	NOMENCLATURE OR DESCRIPTION	SPEC/STD	SHEET NO.	NOTE
	6						
REF	5	80063	A3092728	TEST PROCEDURE/DATA SHEET POWER AND SIGNAL CABLE TEST			
	3	96906	MS25036-153	TERMINAL LUG			
	3						
	2						
	1	80063	A3092927-2	CABLE MOLDED 90° CONNECTOR			6
QTY REQD	FIND NO.	FSCM NO.	PART NUMBER OR IDENTIFYING NO.	NOMENCLATURE OR DESCRIPTION	SPEC/STD	SHEET NO.	NOTE
PARTS LIST							

A3092719

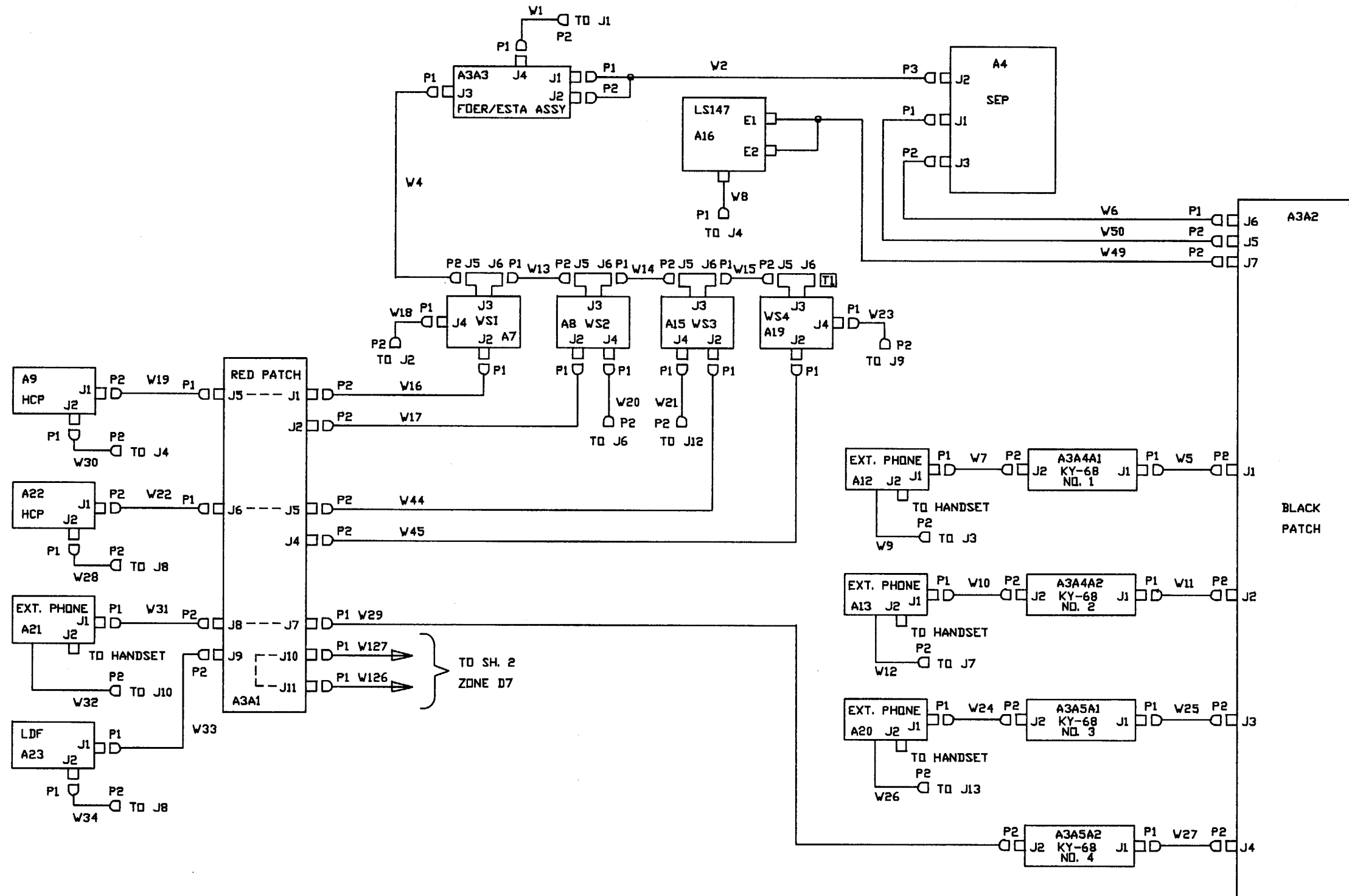

A3092752

Interconnecting Diagram, OPN System - AN/TYQ30 (Sheet 1 of 2)

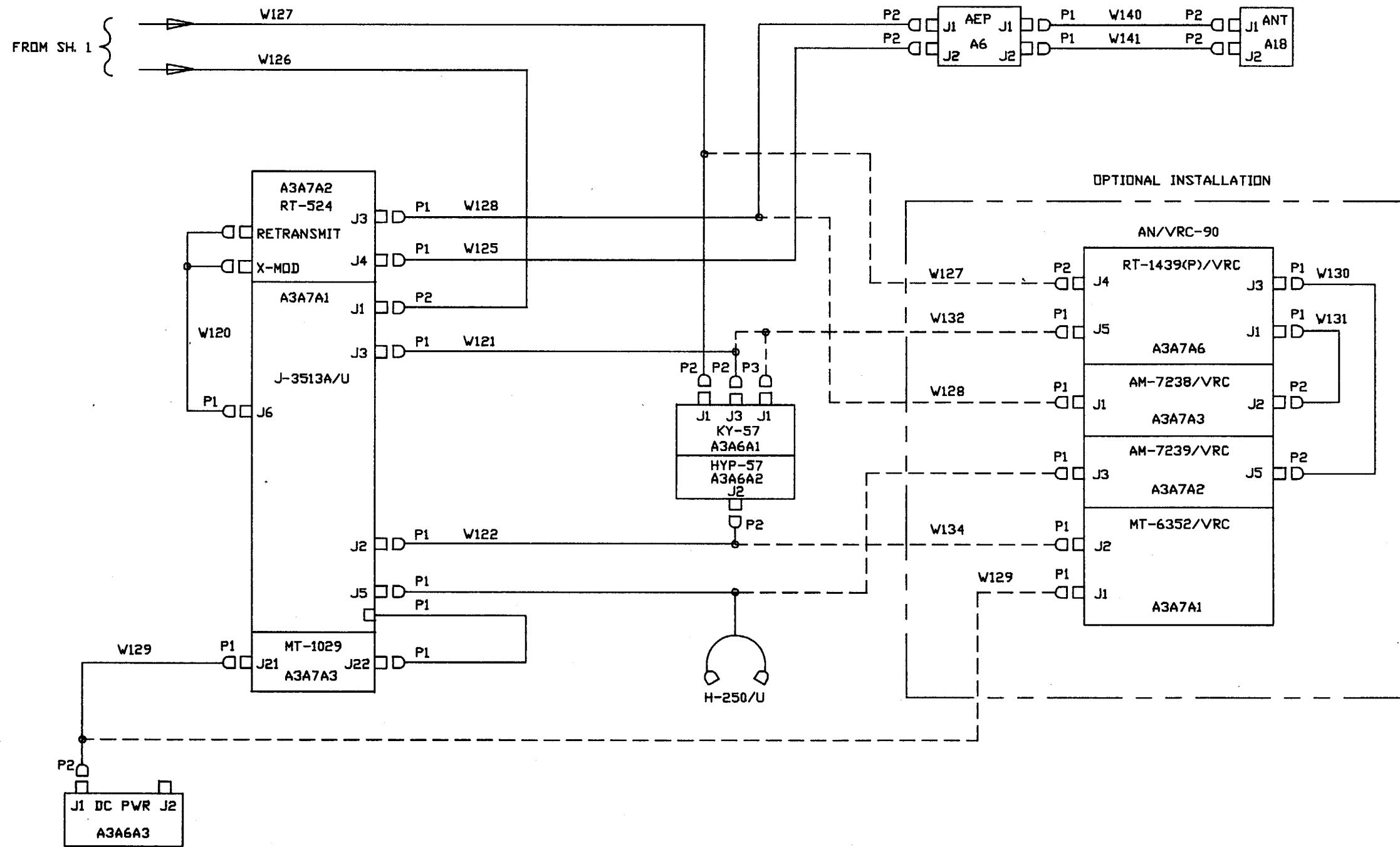

A3092752

Interconnecting Diagram, OPN System - AN/TYQ30 (Sheet 2 of 2)

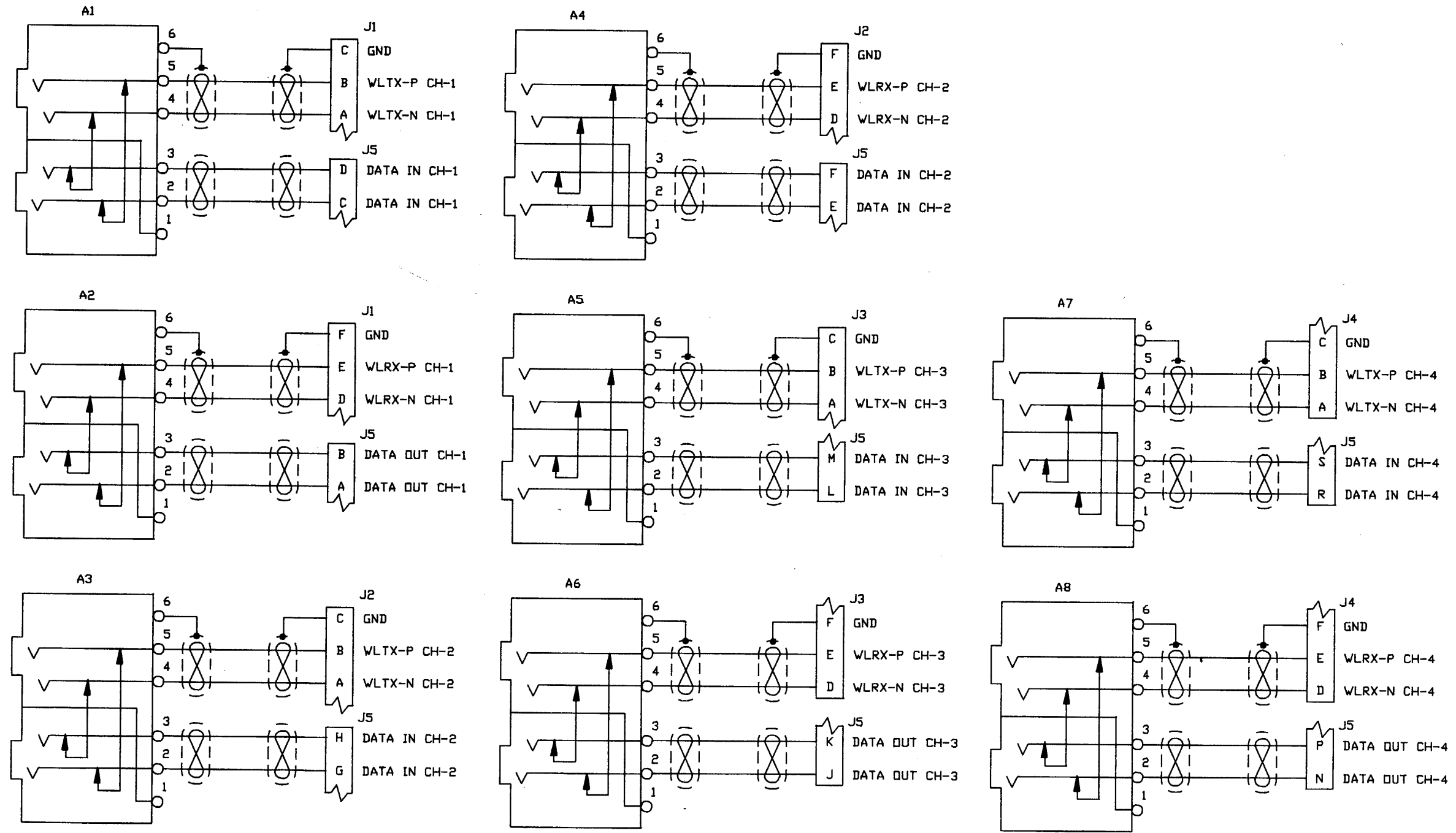

NOTES :

1. PARTIAL REFERENCE DESIGNATIONS ARE SHOWN.
FOR COMPLETE REFERENCE DESIGNATION, PREFIX WITH UNIT NUMBER AND SUBASSEMBLY DESIGNATION.
2. ALL UNUSED POSITIONS IN CONNECTORS J1-J7 WILL BE FILLED WITH CONTACTS.

A3092761

Schematic Diagram, Black Patch Panel, OPN (Sheet 1 of 2)

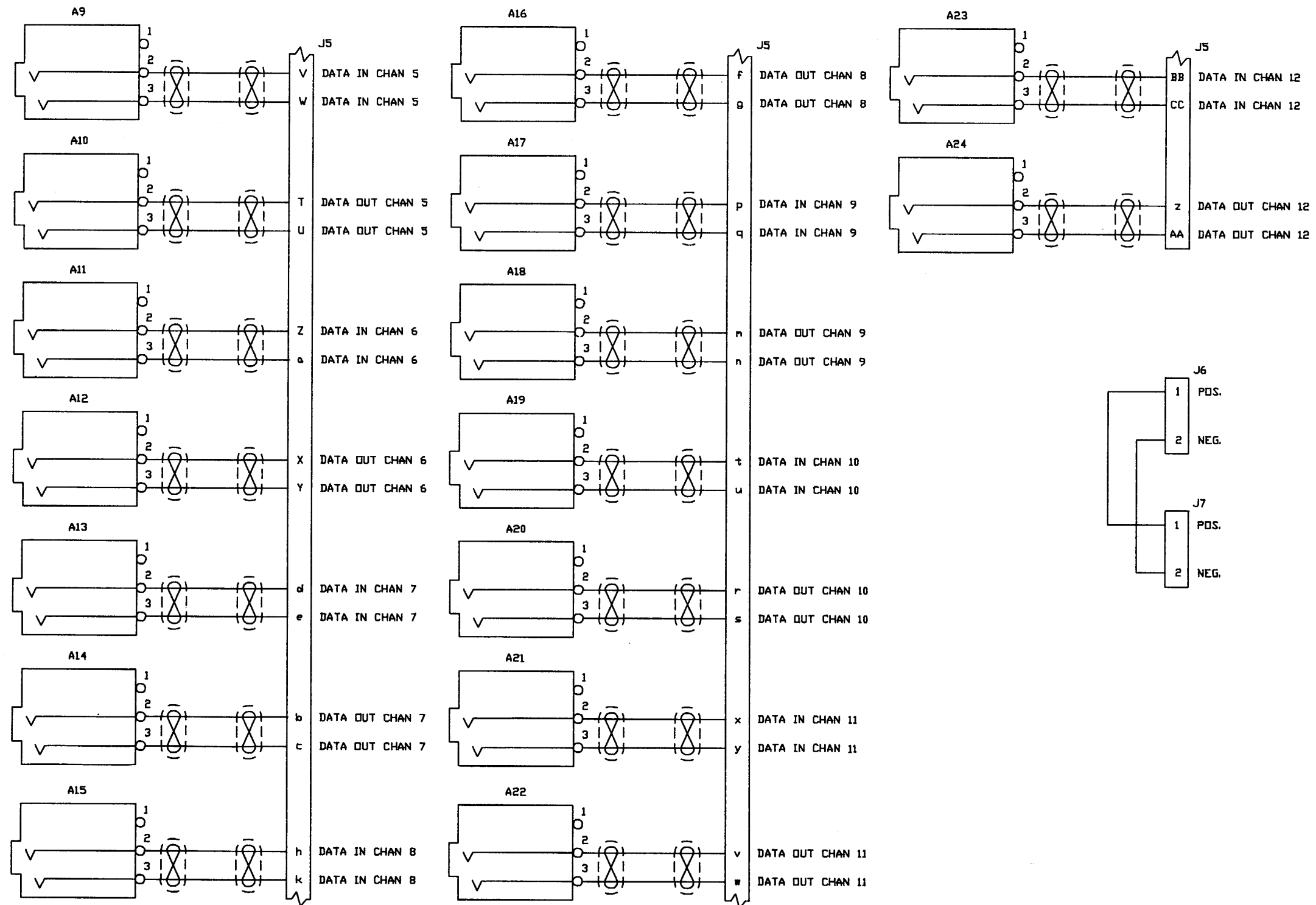

Schematic Diagram, Black Patch Panel, OPN (Sheet 2 of 2)

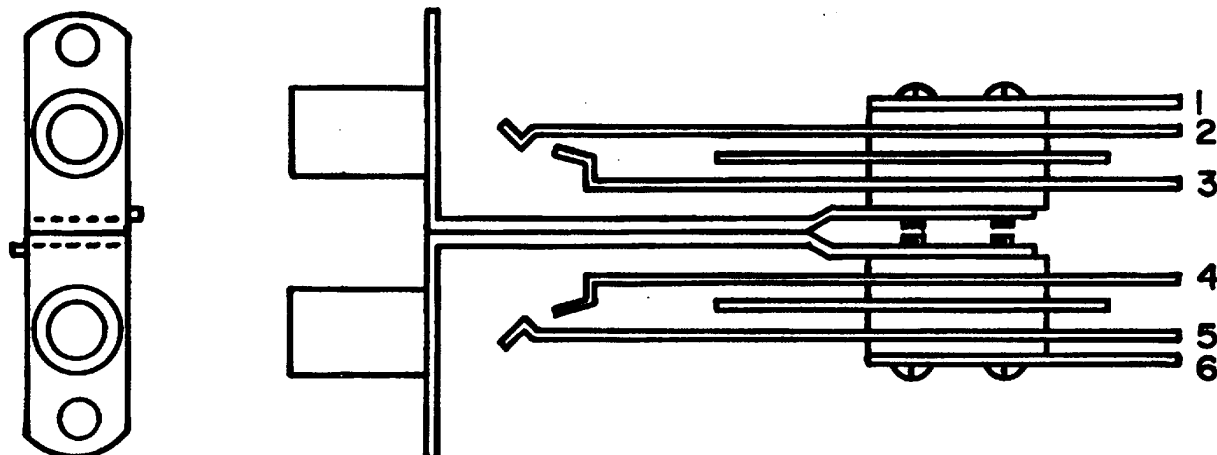

FIGURE 1

0364N	THIS DOCUMENT HAS BEEN PURCHASED BY THE GOVERNMENT AND MAY BE REPRODUCED AND USED IN CONNECTION WITH ANY GOVERNMENT PROCUREMENT OR MAINTENANCE OPERATION	SIZE	FSCM NO.	DRAWING NO	
		A	80063	A3092762	
		SCALE	NONE	LTR	H SHEET 3

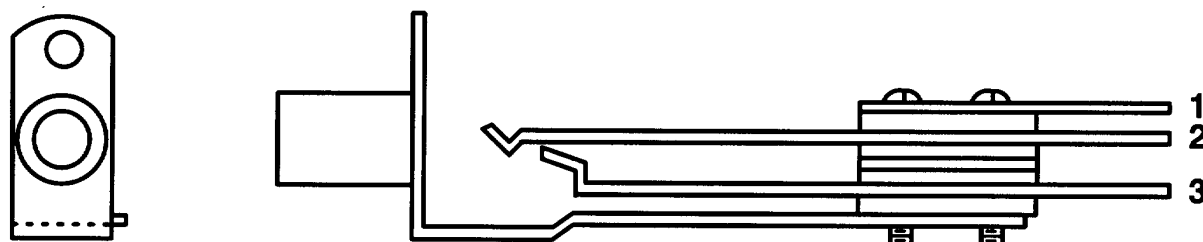

FIGURE 2

	THIS DOCUMENT HAS BEEN PURCHASED BY THE GOVERNMENT AND MAY BE REPRODUCED AND USED IN CONNECTION WITH ANY GOVERNMENT PROCUREMENT OR MAINTENANCE OPERATION	SIZE	FSCM NO.	DRAWING NO	
		A	80063	A3092762	
		SCALE	NONE	LTR	H SHEET 4

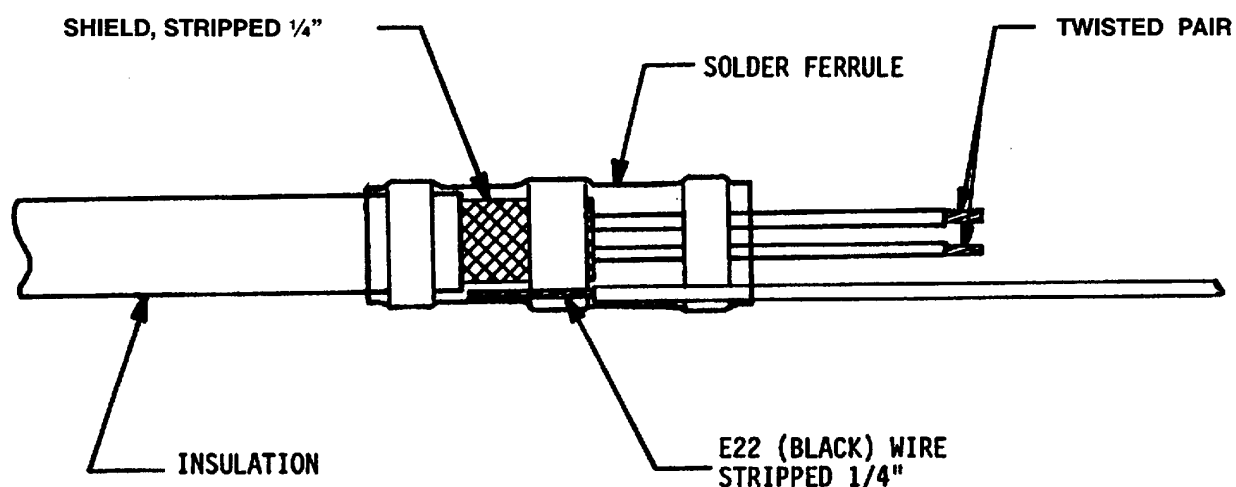

FIGURE 3

0364N	THIS DOCUMENT HAS BEEN PURCHASED BY THE GOVERNMENT AND MAY BE REPRODUCED AND USED IN CONNECTION WITH ANY GOVERNMENT PROCUREMENT OR MAINTENANCE OPERATION	SIZE	FSCM NO.	DRAWING NO	
		A	80063	A3092762	
		SCALE	NONE	LTR	H SHEET 5

QTY	ITEM	PART NO.	DESCRIPTION	SPEC. STD	FSCM NO.
5	1	M16878/4BFB0	WIRE, 22 AWG, STRANDED, BLACK (FT)	MIL-W-16878/4	81349
2					
9	3	M23053/4-201	TAT-125-1/4-CLEAR (FT)	MIL-I-23053/4	81349
50	4	M27500-22TE2TI4	WIRE, TWISTED, 22 AWG, SHIELDED (FT)	MIL-C-27500	81349
32	5	M83519/2-08	FERRULE, SOLDER	MIL-S-83519/2	81349
REF	6	MS27468T9B98P	CONNECTOR, CIRCULAR (J7)		96906
RFF	7	MS27468T9B98S	CONNECTOR, CIRCULAR (J6)		96906
REF	8	MS3124FI2-8P	CONNECTOR, CIRCULAR (J1-J4)		96906
REF	9	MS3124F22-55P	CONNECTOR, CIRCULAR (J5)		96906

THIS DOCUMENT HAS BEEN PURCHASED BY THE GOVERNMENT AND MAY BE REPRODUCED AND USED IN CONNECTION WITH ANY GOVERNMENT PROCUREMENT OR MAINTENANCE OPERATION	SIZE	FSCM NO.	DRAWING NO	
	A	80063	A3092762	
		SCALE	NONE	LTR H SHEET 6

A3092762

WIRING LIST, POINT-TO-POINT, BLACK OPN PATCH PANEL (Sheets 5 & 6 of 11)

WIRE NO. OR COLOR	FROM TERMINATION			TO TERMINATION			WIRE		FUNCTION	REMARKS
	REF DES	PIN	(I) ITEM (N) NOTE	REF DES	PIN	(I) ITEM (N) NOTE	ITEM	LENGTH		
1 BLU	A1	2	NI	J5	C	19N3	4	24 IN	DATA IN CH 1	SEP
2 WHT	A1	3	NI	J5	D	19N3	4	24 IN	DATA IN CH 1	SEP
3 WHT	A1	4	NI	J1	A	18N3	4	24 IN	WLTX-N CH 1	KY-68
4 BLU	A1	5	NI	J1	B	18N3	4	24 IN	WLTX-P CH 1	KY-68
5	A1	6	15N1N5	J1	C	1518N3N5	4	24 IN	GND	KY-68
6 BLU	A2	2	N1	J5	A	19N3	4	24 IN	DATA OUT CH 1	SEP
7 WHT	A2	3	N1	J5	B	19N3	4	24 IN	DATA OUT CH 1	SEP
8 WHT	A2	4	N1	J1	D	18N3	4	24 IN	WLRX-N CH 1	KY-68
9 BLU	A2	5	N1	J1	E	18N3	4	24 IN	WLRX-P CH 1	KY-68
10	A2	6	15N1N5	J1	F	1518N3N5	4	24 IN	GND	KY-68
11 BLU	A3	2	N1	J5	G	19N3	4	24 IN	DATA IN CH 2	SEP
12 WHT	A3	3	N1	J5	H	19N3	4	24 IN	DATA IN CH 2	SEP
13 WHT	A3	4	N1	J2	A	18N3	4	24 IN	WLTX IN CH 2	KY-68
14 BLU	A3	5	N1	J2	B	18N3	4	24 IN	WLTX-P CH 2	KY-68
15	A3	6	15N1N5	J2	C	1518N3N5	4	24 IN	GND	KY-68
16 BLU	A4	2	N1	J5	E	19N3	4	24 IN	DATA OUT CH 2	SEP
17 WHT	A4	3	N1	J5	F	19N3	4	24 IN	DATA OUT CH 2	SEP

0364N	THIS DOCUMENT HAS BEEN PURCHASED BY THE GOVERNMENT AND MAY BE REPRO- DUCED AND USED IN CONNECTION WITH ANY GOVERNMENT PROCUREMENT OR MAINTENANCE OPERATION	SIZE	FSCM NO.	DRAWING NO	
		A	80063	A3092762	
		SCALE	NONE	LTR	H SHEET 9

WIRE NO. OR COLOR	FROM TERMINATION			TO TERMINATION			WIRE		FUNCTION	REMARKS
	REF DES	PIN	(I) ITEM (N) NOTE	REF DES	PIN	(I) ITEM (N) NOTE	ITEM	LENGTH		
18 WHT	A4	4	N	J2	D	18N3	4	24 IN	WLRX-N CH 2	KY-68
19 BLU	A4	5	N1	J2	E	18N3	4	24 IN	WLRX-P CH 2	KY-68
20	A4	6	15N1N5	J2	F	1518N3N5	4	24 IN	GND	KY-68
21 BLU	A5	2	N1	J5	L	19N3	4	24 IN	DATA IN CH 3	SEP
22 WHT	A5	3	N1	J5	M	19N3	4	24 IN	DATA IN CH 3	SEP
23 WHT	A5	4	N1	J3	A	18N3	4	24 IN	WLRX-N CH 3	KY-68
24 BLU	A5	5	N1	J3	B	18N3	4	24 IN	WLRX-P CH 3	KY-68
25	A5	6	15N1N5	J3	C	1518N3N5	4	24 IN	GND	KY-68
26 BLU	A6	2	N1	J5	J	19N3	4	24 IN	DATA OUT CH 3	SEP
27 WHT	A6	3	N1	J5	K	19N3	4	24 IN	DATA OUT CH 3	SEP
28 WHT	A6	4	N1	J3	D	18N3	4	24 IN	WLRX-N CH 3	KY-68
29 BLU	A6	5	N1	J3	E	18N3	4	24 IN	WLRX-P CH 3	KY-68
30	A6	6	15N1N5	J3	F	1518N3N5	4	24 IN	GND	KY-68
31 BLU	A7	2	N1	J5	R	19N3	4	24 IN	DATA IN CH 4	SEP
32 WHT	A7	3	N1	J5	S	19N3	4	24 IN	DATA IN CH 4	SEP
33 WHT	A7	4	N1	J4	A	18N3	4	24 IN	WLTX-N CH 4	KY-68
34 BLU	A7	5	N1	J4	B	18N3	4	24 IN	WLTX-P CH 4	KY-68

THIS DOCUMENT HAS BEEN PURCHASED BY THE GOVERNMENT AND MAY BE REPRO- DUCED AND USED IN CONNECTION WITH ANY GOVERNMENT PROCUREMENT OR MAINTENANCE OPERATION	SIZE	FSCM NO.	DRAWING NO	
	A	80063	A3092762	
		SCALE	NONE	LTR H SHEET 10

WIRE NO. OR COLOR	FROM TERMINATION			TO TERMINATION			WIRE		FUNCTION	REMARKS
	REF DES	PIN	(I) ITEM (N) NOTE	REF DES	PIN	(I) ITEM (N) NOTE	ITEM	LENGTH		
35	A7	6	15N1 N5	J4	C	1518N3N5	4	24IN	GND	KY-68
36 BLU	A8	2	N1	J5	N	19N3	4	24 IN	DATA OUT CH 4	SEP
37 WHT	A8	3	N1	J5	P	19N3	4	24IN	DATA OUT CH 4	SEP
38 WHT	A8	4	N1	J4	D	18N3	4	24 IN	WLRX-N CH 4	KY-68
39 BLU	A8	5	N1	J4	E	18N3	4	24 IN	WLRX-P CH 4	KY-68
40	A8	6	15N1N5	J4	F	1518N3N5	4	24 IN	GND	KY-68
41 BLU	A9	2	N2	J5	V	19N3	4	24 IN	DATA IN CH 5	SEP
42 WHT	A9	3	N2	J5	W	19N3	4	24 IN	DATA IN CH 5	SEP
43 BLU	A10	2	N2	J5	T	19N3	4	24 IN	DATA OUT CH 5	SEP
44 WHT	A10	3	N2	J5	U	19N3	4	24IN	DATA OUT CH 5	SEP
45 BLU	All	2	N2	J5	Z	19N3	4	24 IN	DATA IN CH 6	SEP
46 WHT	A11	3	N2	J5	a	19N3	4	24 IN	DATA IN CH 6	SEP
47 BLU	A12	2	N2	J5	X	19N3	4	24 IN	DATA OUT CH 6	SEP
48 WHT	A12	3	N2	J5	Y	19N3	4	24 IN	DATA OUT CH 6	SEP
49 BLU	A13	2	N2	J5	d	19N3	4	24 IN	DATA IN CH 7	SEP
50 WHT	A13	3	N2	J5	e	19N3	4	24IN	DATA IN CH 7	SEP
51 BLU	A14	2	N2	J5	b	19N3	4	24 IN	DATA OUT CH 7	SEP

0364N

THIS DOCUMENT HAS BEEN PURCHASED BY THE GOVERNMENT AND MAY BE REPRODUCED AND USED IN CONNECTION WITH ANY GOVERNMENT PROCUREMENT OR MAINTENANCE OPERATION

SIZE
A

FSCM NO.
80063

DRAWING NO
A3092762

SCALE NONE LTR H SHEET 9

WIRE NO. OR COLOR	FROM TERMINATION			TO TERMINATION			WIRE		FUNCTION	REMARKS
	REF DES	PIN	(I) ITEM (N) NOTE	REF DES	PIN	(I) ITEM (N) NOTE	ITEM	LENGTH		
52 WHT	A14	3	N2	J5	c	19N3	4	24 IN	DATA OUT CH 7	SEP
53 BLU	A15	2	N2	J5	h	19N3	4	24 IN	DATA IN CH 8	SEP
54 WHT	A15	3	N2	J5	k	19N3	4	24 IN	DATA IN CH 8	SEP
55 BLU	A16	2	N2	J5	f	19N3	4	24 IN	DATA OUT CH 8	SEP
56 WHT	A16	3	N2	J5	g	19N3	4	24 IN	DATA OUT CH 8	SEP
57 BLU	A17	2	N2	J5	p	19N3	4	24 IN	DATA IN CH 9	SEP
58 WHT	A17	3	N2	J5	q	19N3	4	24 IN	DATA IN CH 9	SEP
59 BLU	A18	2	N2	J5	m	19N3	4	24 IN	DATA OUT CH 9	SEP
60 WHT	A18	3	N2	J5	n	19N3	4	24 IN	DATA OUT CH 9	SEP
61 BLU	A19	2	N2	J5	t	19N3	4	24 IN	DATA IN CH 10	SEP
62 WHT	A19	3	N2	J5	u	19N3	4	24 IN	DATA IN CH 10	SEP
63 BLU	A20	2	N2	J5	r	19N3	4	24 IN	DATA OUT CH 10	SEP
64 WHT	A20	3	N2	J5	s	19N3	4	24 IN	DATA OUT CH 10	SEP
65 BLU	A21	2	N2	J5	x	19N3	4	24 IN	DATA IN CH 11	SEP
66 WHT	A21	3	N2	J5	y	19N3	4	24 IN	DATA IN CH 11	SEP
67 BLU	A22	2	N2	J5	v	19N3	4	24 IN	DATA OUT CH 11	SEP
68 WHT	A22	3	N2	J5	w	19N3	4	24 IN	DATA OUT CH 11	SEP

THIS DOCUMENT HAS BEEN PURCHASED BY THE GOVERNMENT AND MAY BE REPRODUCED AND USED IN CONNECTION WITH ANY GOVERNMENT PROCUREMENT OR MAINTENANCE OPERATION

SIZE
A

FSCM NO.
80063

DRAWING NO
DRAWING NO
A3092762

SCALE NONE LTR H SHEET 10

A3092762

WIRE NO. OR COLOR	FROM TERMINATION			TO TERMINATION			WIRE		FUNCTION	REMARKS
	REF DES	PIN	(I) ITEM (N) NOTE	REF DES	PIN	(I) ITEM (N) NOTE	ITEM	LENGTH		
69 BLU	A23	2	N2	J5	BB	19N3	4	24 IN	DATA IN CH 12	SEP
70 WHT	A23	3	N2	J5	CC	19N3	4	24 IN	DATA IN CH 12	SEP
71 BLU	A24	2	N2	J5	z	19N3	4	24 IN	DATA OUT CH 12	SEP
72 WHT	14	3	N2	J5	1	19N3	4	24 IN	DATA OUT CH 12	SEP
74	J6	1	16N4	J7	1	17N4	1	8 IN	POS	LS/147
76	J6	2	16N4	J7	2	17N4	1	8 IN	NEG	LS/147

0364N	THIS DOCUMENT HAS BEEN PURCHASED BY THE GOVERNMENT AND MAY BE REPRO- DUCED AND USED IN CONNECTION WITH ANY GOVERNMENT PROCUREMENT OR MAINTENANCE OPERATION	SIZE	FSCM NO.	DRAWING NO	
		A	80063	A3092762	
		SCALE	NONE	LTR	H SHEET 11

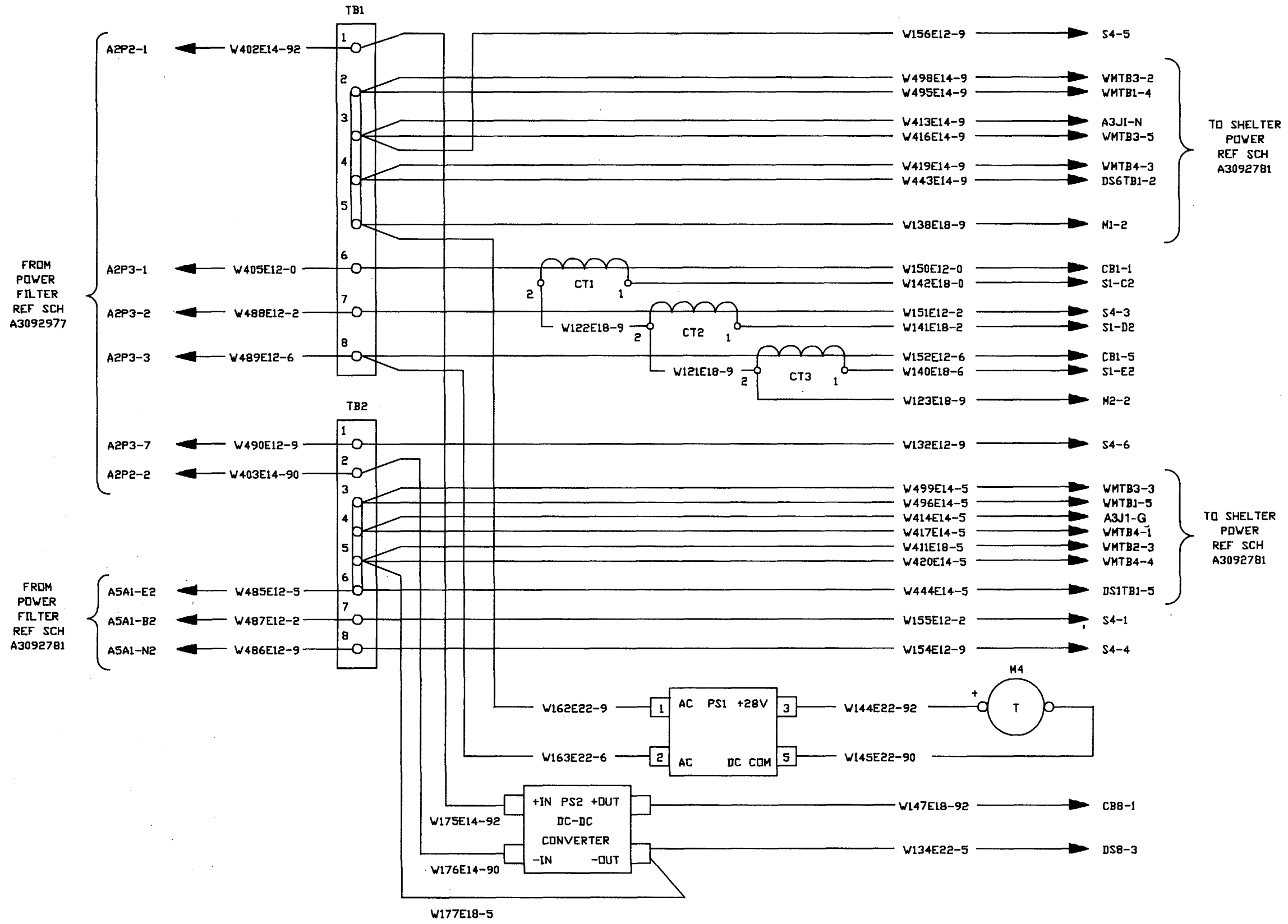

Schematic Diagram, Pwr Distr Panel, OPN (Sheet 1 of 2)

PARTS LIST					
QTY	ITEM	PART NO.	DESCRIPTION	SPEC/STD	FSCM NO.
13	1	MS25036-102	TERMINAL, LUG, RING, NO. 6, 22-18 AWG		96906
20	2	MS25036-103	TERMINAL, LUG, RING, NO. 10, 22-18 AWG		96906
8	3	MS25036-107	TERMINAL, LUG, RING, NO. 6, 16-14 AWG		96906
40	4	MS25036-108	TERMINAL, LUG, RING, NO. 10, 16-14 AWG		96906
5	5	MS25036-111	TERMINAL, LUG, RING, NO. 6, 12-10 AWG		96906
23	6	MS25036-112	TERMINAL, LUG, RING, NO. 10, 12-10 AWG		96906
4	7	MS25036-148	TERMINAL, LUG, RING, NO. 4, 22-18 AWG		96906
9	8	MS25036-149	TERMINAL, LUG, RING, NO. 8, 22-18 AWG		96906
8	9	MS25036-150	TERMINAL, LUG, RING, 1/4, 22-18 AWG		96906
2	10	MS25036-153	TERMINAL, LUG, RING, NO. 8, 16-14 AWG		96906
165	11	M23053/5-103-9	INSULATION SLEEVING (INCHES)	MIL-I-23053/5	81349
120	12	M23053/5-105-9	INSULATION SLEEVING (INCHES)	MIL-I-23053/5	81349
AR	E12-0	M16878/4BLE0	WIRE, 12 AWG, BLACK	MIL-W-16878/4	81349
AR	E12-2	M16878/4BLE2	WIRE, 12AWG, RED	MIL-W-16878/4	81349
AR	E12-6	M16878/4BLE6	WIRE, 12AWG, BLUE	MIL-W-16878/4	81349
AR	E12-9	M16878/4BLE9	WIRE, 12 AWG, WHITE	MIL-W-16878/4	81349
AR	E14-0	M16878/4BKE0	WIRE, 14 AWG, BLACK	MIL-W-16878/4	81349

THIS DOCUMENT HAS BEEN PURCHASED BY THE GOVERNMENT AND MAY BE REPRODUCED AND USED IN CONNECTION WITH ANY GOVERNMENT PROCUREMENT OR MAINTENANCE OPERATION	SIZE	FSCM NO.	DRAWING NO.	
	A	80063	A3092771	
	SCALE	NONE	LTR	D
			SHEET	3

PARTS LIST					
QTY	ITEM	PART NO.	DESCRIPTION	SPEC/STD	FSCM NO.
AR	E14-2	M16878/4BKE2	WIRE, 14 AWG, RED	MIL-W-16878/4	
AR	E14-5	M16878/4BKE5	WIRE, 14 AWG, GREEN	MIL-W-16878/4	
AR	E14-6	M16878/4BKE6	WIRE, 14 AWG, BLUE	MIL-W-16878/4	
AR	E14-9	M16878/4BKE9	WIRE, 14 AWG, WHITE	MIL-W-16878/4	
AR	E14-90	M16878/4BKE90	WIRE, 14 AWG, WHITE/BLACK	MIL-W-16878/4	
AR	E14-92	M16878/4BKE92	WIRE, 14 AWG, WHITE/RED	MIL-W-16878/4	
AR	E18-0	M16878/4BHE0,	WIRE, 18-AWG, BLACK	MIL-W-16878/4	
AR	E18-2	M16878/4BHE2	WIRE, 18 AWG, RED	MIL-W-16878/4	
AR	E18-6	M16878/4BHE6	WIRE, 18 AWG, BLUE	MIL-W-16878/4	
AR	E18-9	M16878/4BHE9	WIRE, 18 AWG, WHITE	MIL-W-16878/4	
AR	E18-5	M16878/4BHE5	WIRE, 18 AWG, GREEN	MIL-W-16878/4	
AR	E18-90	M16878/4BHE90	WIRE, 18 AWG, WHITE/BLACK	MIL-W-16878/4	
AR	E18-92	M16878/4BHE92	WIRE, 18 AWG, WHITE/RED	MIL-W-16878/4	
AR	E22-0	M16878/4BFEO	:WIRE, 22 AWG, BLACK	MIL-W-16878/4	
AR	E22-2	M16878/4BFE2	WIRE, 22 AWG, RED	MIL-W-16878/4	
AR	E22-6	M16878/4BFE6	WIRE, 22 AWG, BLUE	MIL-W-16878/4	
AR	E22-9	M16878/4BFE9	WIRE, 22 AWG, WHITE	MIL-W-16878/4	

THIS DOCUMENT HAS BEEN PURCHASED BY THE GOVERNMENT AND MAY BE REPRODUCED AND USED IN CONNECTION WITH ANY GOVERNMENT PROCUREMENT OR MAINTENANCE OPERATION	SIZE	FSCM NO.	DRAWING NO.	
	A	80063	A3092771	
	SCALE	NONE	LTR	C
			SHEET	4

A3092771

WIRING LIST, POINT-TO-POINT, POWER DISTRIBUTION PANEL-OPN (Sheets 3 & 4 of 11)

PARTS LIST					
QTY	ITEM	PART NO.	DESCRIPTION	SPEC/STD	FSCM NO.
AR	E22-5	M16878/4BFE5	WIRE, 22 AWG, GREEN	MIL-W-16878/4	813
AR	E22-90	M16878/4BFE90	WIRE, 22 AWG, WHITE/BLACK	MIL-W-16878/4	813
AR	E22-92	M16878/4BFE92	WIRE, 22 AWG, WHITE/RED	MIL-W-16878/4	813

THIS DOCUMENT HAS BEEN PURCHASED BY THE GOVERNMENT AND MAY BE REPRODUCED AND USED IN CONNECTION WITH ANY GOVERNMENT PROCUREMENT OR MAINTENANCE OPERATION	SIZE A	FSCM NO. 80063	DRAWING NO. A3092771 SHEET 5
	SCALE NONE	LTR C	SHEET 5

WIRE NO. OR COLOR	FROM TERMINATION			TO TERMINATION			WIRE		
			(1) ITEM			(1) ITEM			
W102E12-0	CB3	1	16	CB1	2	16	E12-0	PHASE A	BLACK
W105E12-6	CB4	1	16	CB1	6	16	E12-6	PHASE C	BLUE
W106E12-6	CB5	1	16	CB4	1	16	E12-6	PHASE C	BLUE
W107E12-2	CB6	1	16	CB1	4	16	E12-2	PHASE B	RED
W108E12-2	CB7	1	16	CB6	1	16	E12-2	PHASE B	RED
W109E12-2	CB2	1	16	CB7	1	16	E12-2	PHASE B	RED
W110E22-2	CB1	4	12	DS1	2	N2	E22-2	PHASE B	RED
W112E22-0	CB3	2	12	DS3	2	N2	E22-0	PHASE A	BLACK
W113E22-6	CB4	2	12	DS4	2	N2	E22-6	PHASE C	BLUE
W114E22-6	CB5	2	12	DS5	2	N2	E22-6	PHASE C	BLUE
W115E22-2	CB6	2	12	DS6	2	N2	E22-2	PHASE B	RED
W116E22-2	CB7	2	12	DS7	2	N2	E22-2	PHASE B	RED
W117E22-2	CB2	2	12	DS2	2	N2	E22-2	PHASE B	RED
W118E18-6	CB1	5	12	S1	E1	I1	E18-6	PHASE C	BLUE
W119E18-2	CB1	3	12	S1	D1	I1	E18-2	PHASE B	RED
W120E18-0	CB1	1	12	S1	C1	I1	E18-0	PHASE A	BLACK
W121E18-9	CT2	2	18	CT3	2	18	E18-9	CT COMMON	WHITE

A3092771

THIS DOCUMENT HAS BEEN PURCHASED BY THE GOVERNMENT AND MAY BE REPRODUCED AND USED IN CONNECTION WITH ANY GOVERNMENT PROCUREMENT OR MAINTENANCE OPERATION	SIZE A	FSCM NO. 80063	DRAWING NO. SHEET 6 A3092771
	SCALE NONE	LTR C	SHEET 6

WIRE NO. OR COLOR	FROM TERMINATION			TO TERMINATION			WIRE		FUNCTION	REMARKS
	REF DES	PIN	(I) ITEM (N) NOTE	REF DES	PIN	(I) ITEM (N) NOTE	ITEM	LENGTH		
W122E18-9	CT1	2	18	CT2	2	18	E18-9		CT COMMON	WHITE
W123E18-9	CT3	2	18	M2	2	19	E18-9		CT COMMON	WHITE
W124E14-2	CB2	2	14	S2	2	13	E14-2		PHASE B	RED
W125E22-9	DS1	1	N2	DS3	1	N2	E22-9		NEUTRAL	WHITE
W127E22-9	DS3	1	N2	DS4	1	N2	E22-9		NEUTRAL	WHITE
W128E22-9	DS4	1	N2	DS5	1	N2	E22-9		NEUTRAL	WHITE
W129E22-9	DS5	1	N2	DS6	1	N2	E22-9		NEUTRAL	WHITE
W130E22-9	DS6	1	N2	DS7	1	N2	E22-9		NEUTRAL	WHITE
W131E22-9	DS7	1	N2	DS2	1	N2	E22-9		NEUTRAL	WHITE
W132E12-9	TB2	1	16	S4	6	15	E12-9		NEUTRAL	WHITE
W133E22-92	DS8	1	N2	CB8	1	12	E22-92		28 VDC	WHT/RED
W134E22-5	PS2	-OUT	N2	DS8	3	N2	E22-5		GROUND	GREEN
W135E18-0	S1	H1	I1	M1	1	19	E18-0		V METER LEAD	BLACK
W136E18-0	M1	1	19	K1	1	I1	E18-0		XDCR LEAD	BLACK
W137E18-9	M1	2	19	K1	2	11	E18-9		NEUTRAL	WHITE
W138E18-9	TB1	5	12	MI	2	19	E18-9		NEUTRAL	WHITE
W139E18-0	S1	H2	I1	M2	1	19	E18-0		A METER LEAD	BLACK

THIS DOCUMENT HAS BEEN PURCHASED BY THE GOVERNMENT AND MAY BE REPRO- DUCED AND USED IN CONNECTION WITH ANY GOVERNMENT PROCUREMENT OR MAINTENANCE OPERATION	SIZE A	FSCM NO. 80063	DRAWING NO. A3092771 SHEET 7
	SCALE NONE	LTR B	SHEET 7

WIRE NO. OR COLOR	FROM TERMINATION			TO TERMINATION			WIRE		FUNCTION	REMARKS
	REF DES	PIN	(I) ITEM (N) NOTE	REF DES	PIN	(I) ITEM (N) NOTE	ITEM	LENGTH		
W140E18-6	CT3	1	18	S1	E2	I1	E18-6		PHASE C	BLUE
W141E18-2	CT2	1	18	S1	D2	I1	E18-2		PHASE B	RED
W142E18-0	CT1	1	18	S1	C2	I1	E18-0		PHASE A	BLACK
W143E14-2	S2	1	13	S3	2	13	E14-2		PHASE B	RED
W144E22-92	PS1	3	17	M4	+	N2	E22-92		28 VDC	WHT/RED
W145E22-90	PS1	5	17	M4	-	N2	E22-90		DC COMMON	WHT/BLK
W146E22-5	DS8	2	N2	CB8	NO	N2	E22-5		GROUND	GREEN
W147E18-92	PS2	+OUT	N2	CB8	1	12	E18-92		28 VDC	WHT/RED
W148E18-90	M3	-	19	K1	-	I1	E18-90		F METER NEG	WHT/BLK
W149E18-92	M3	+	19	K1	+	I1	E18-92		F METER POS	WHT/BLK
W150E12-0	TB1	6	16	CB1	1	16N5	E12-0		PHASE A	BLACK
W151E12-2	TB1	7	16	S4	3	16N5	E12-2		PHASE B	RED
W152E12-6	TB1	8	16	CB1	5	16N5	E12-6		PHASE C	BLUE
W153E22-92	DS10	1	N2	CB8	1	12	E22-92		28 VDC	WHT/RED
W154E12-9	TB2	8	16	S4	4	15	E12-9		NEUTRAL	WHITE
W155E12-2	TB2	7	16	S4	1	15	E12-2		PHASE B	RED
W156E12-9	TB1	3	16	S4	5	15	E12-9		NEUTRAL	WHITE

A3092771

THIS DOCUMENT HAS BEEN PURCHASED BY THE GOVERNMENT AND MAY BE REPRO- DUCED AND USED IN CONNECTION WITH ANY GOVERNMENT PROCUREMENT OR MAINTENANCE OPERATION	SIZE A	FSCM NO. 80063	DRAWING NO. A3092771 SHEET 8
	SCALE NONE	LTR A	SHEET 8

WIRING LIST, POINT-TO-POINT, POWER DISTRIBUTION PANEL-OPN (Sheets 7 & 8 of 11)

WIRE NO. OR COLOR	FROM TERMINATION			TO TERMINATION			WIRE		FUNCTION	REMARKS
	REF DES	PIN	(I) ITEM (N) NOTE	REF DES	PIN	(I) ITEM (N) NOTE	ITEM	LENGTH		
W157E22-9	DS9	1	N2	KI	2	11	E22-9		NEUTRAL	WHITE
W158E12-2	S4	2	15	CB1	3	16	E12-2		PHASE B	RED
W159E22-5	DS10	2	N2	DS8	3	N2	E22-5		GROUND	GREEN
W160E22-2	CB1.	3	12	DS9	2	N2	E22-2		PHASE B	RED
W161E22-9	DS9	1	N2	DS1	1	N2	E22-9		NEUTRAL	WHITE
W1 62E22-9	TB1	5	12	PS1	1	17	E22-9		NEUTRAL	WHITE
W163E22-6	TB1	8	12	PS1	2	17	E22-6		PHASE C	BLUE
W1 64E22-2	DS9	2	N2	DS9	3	N2	E22-2		PHASE B	RED
W1 65E22-2	DS9	3	N2	DS1	3	N2	E22-2		PHASE B	RED
W166E22-2	DS1	3	N2	DS6	3	N2	E22-2		PHASE B	RED
W1 67E22-2	DS6	3	N2	DS7	3	N2	E22-2		PHASE B	RED
W168E22-2	DS7	3	N2	DS2	3	N2	E22-2		PHASE D	RED
W169E22-6	CB1	5	12	DS4	3	N2	E22-6		PHASE C	BLUE
W170E22-6	DS4	3	N2	DS5	3	N2	E22-6		PHASE C	BLUE
W172E22-0	CB1	1	12	DS3	3	N2	E22-0		PHASE A	BLACK
W173E22-5	DS10	3	N2	CB8	C	N2	E22-5		GROUND	GREEN
W174E22-5	DS10	2	N2	DS10	3	N2	E22-5		GROUND	GREEN

THIS DOCUMENT HAS BEEN PURCHASED BY THE GOVERNMENT AND MAY BE REPRODUCED AND USED IN CONNECTION WITH ANY GOVERNMENT PROCUREMENT OR MAINTENANCE OPERATION	SIZE	FSCM NO.	DRAWING NO.
	A	80063	A3092771
SCALE	NONE	LTR	SHEET 9

WIRE NO. OR COLOR	FROM TERMINATION			TO TERMINATION			WIRE		FUNCTION	REMARKS
	REF DES	PIN	(I) ITEM (N) NOTE	REF DES	PIN	(I) ITEM (N) NOTE	ITEM	LENGTH		
W175E14-92	TB1	1	14	PS2	+IN	N2	E14-92		144 VDC	WHT/RED
W176E14-90	TB2	2	14	PS2	-IN	N2	E14-90		144 RTN	WHT/BLK
W177E18-5	TB2	5	12	PS2	-OUT	N2	E1 8-5		GROUND	GREEN
W410E18-92	CB8	2	12			18N4N7	E18-92	12	28 VDC	WHT/RED
W411E18-5	TB2	5	12			12N4N7	E18-5	12	GROUND	GREEN
W412E14-6	CB5	2	14			14N4N7	E14-6	120	PHASE C	BLUE
W413E14-9	TB1	3	14			14N4N7	E14-9	120	NEUTRAL	WHITE
W414E14-5	TB2	4	14			14N4N7	E14-5	120	GROUND	GREEN
W415E14-2	CB6	2	14			14N4N6	E14-2	12	PHASE B	RED
W416E14-9	TB1	3	14			14N4N6	E14-9	12	NEUTRAL	WHITE
W417E14-5	TB2	4	14.			14N4N6	E14-5	20	GROUND	GREEN
W418E14-2	CB7	2	14			14N4N6	E14-2	20	PHASE B	RED
W419E14-9	TB1	4	14			14N4N6	E14-9	20	NEUTRAL	WHITE
W420E14-5	TB2	5	14			14N4N6	E14-5	20	GROUND	GREEN
W427E14-2	S2	3	13			110N4N6	E14-2	108	PHASE B	RED
W443E14-9	TB1	4	14			14N4N7	E14-9	156	NEUTRAL	WHITE
W444E14-5	TB2	6	14			14N4N7	E14-5	156	GROUND	GREEN
W445E14-2	S3	2	13			110N4N6	E14-2	108	PHASE B	RED

THIS DOCUMENT HAS BEEN PURCHASED BY THE GOVERNMENT AND MAY BE REPRODUCED AND USED IN CONNECTION WITH ANY GOVERNMENT PROCUREMENT OR MAINTENANCE OPERATION	SIZE	FSCM NO.	DRAWING NO.
	A	80063	A3.92771
SCALE	NONE	LTR B	SHEET 10

WIRING LIST, POINT-TO -POINT, POWER DISTRIBUTION PANEL-OPN (Sheets 9 & 10 of 11)

WIRE NO. OR COLOR	FROM TERMINATION			TO TERMINATION			WIRE		FUNCTION	REMARKS
	REF DES	PIN	(I) ITEM (N) NOTE	REF DES	PIN	(I) ITEM (N) NOTE	ITEM	LENGTH		
W446E14-2	S3	1	13			14N4N7	E14-2	156	PHASE B	RED
W447E14-2	S3	3	13			14N4N7	E14-2	156	PHASE B	RED
W453E14-2	S3	1	13			14N4N7	E14-2	20	PHASE B	RED
W492E14-6	CB4	2	14			14N4N7	E14-6	20	PHASE C	BLUE
W495E14-9	TB1	2	14			14N4N7	E14-9	20	NEUTRAL	WHITE
W496E14-5	TB2	3	14			14N4N7	E14-5	20	GROUND	GREEN
W497E14-0	CB3	2	14			14N4N6	E14-0	12	PHASE A	BLACK
W498E14-9	TB1	2	14			14N4N6	E14-9	12	NEUTRAL	WHITE
W499E14-5	TB2	3	14			14N4N6	E14-5	12	GROUND	GREEN

0364N	THIS DOCUMENT HAS BEEN PURCHASED BY THE GOVERNMENT AND MAY BE REPRODUCED AND USED IN CONNECTION WITH ANY GOVERNMENT PROCUREMENT OR MAINTENANCE OPERATION	SIZE	FSCM NO.	DRAWING NO. A3092771
		A	80063	SHEET 11
		SCALE	NONE	LTR A SHEET 11

WIRING LIST, POINT-TO-POINT, POWER DISTRIBUTION PANEL - OPN (Sheet 11 OF 11)

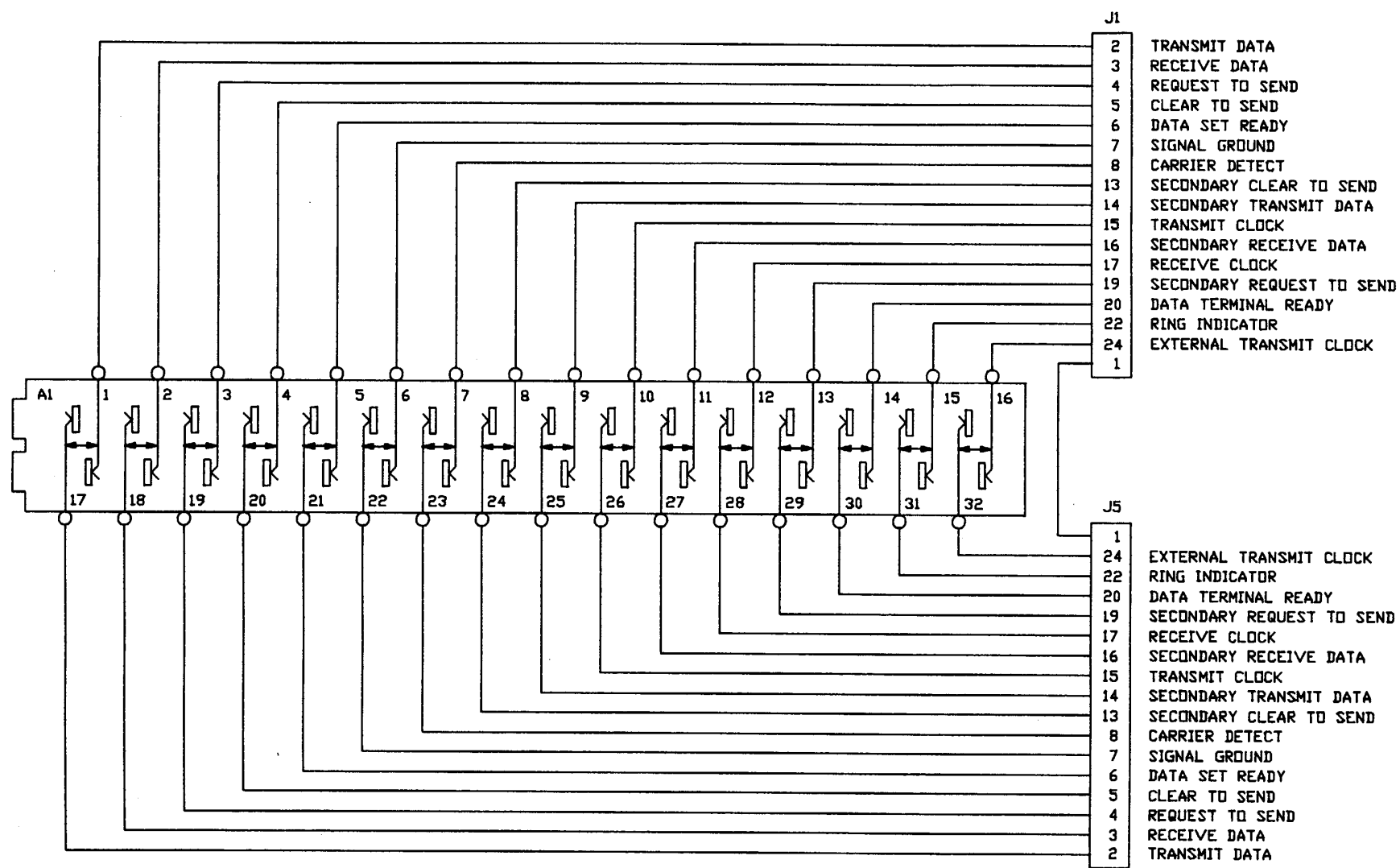

NOTES :

1. PARTIAL REFERENCE DESIGNATIONS ARE SHOWN.
FOR COMPLETE REFERENCE DESIGNATION, PREFIX WITH UNIT NUMBER AND SUBASSEMBLY DESIGNATION.
2. ALL UNUSED POSITIONS IN CONNECTORS J1-J11 WILL BE FILLED WITH CONTACTS.

Schematic Diagram, Red Patch-OPN (Sheet 1 of 7)

A3092772

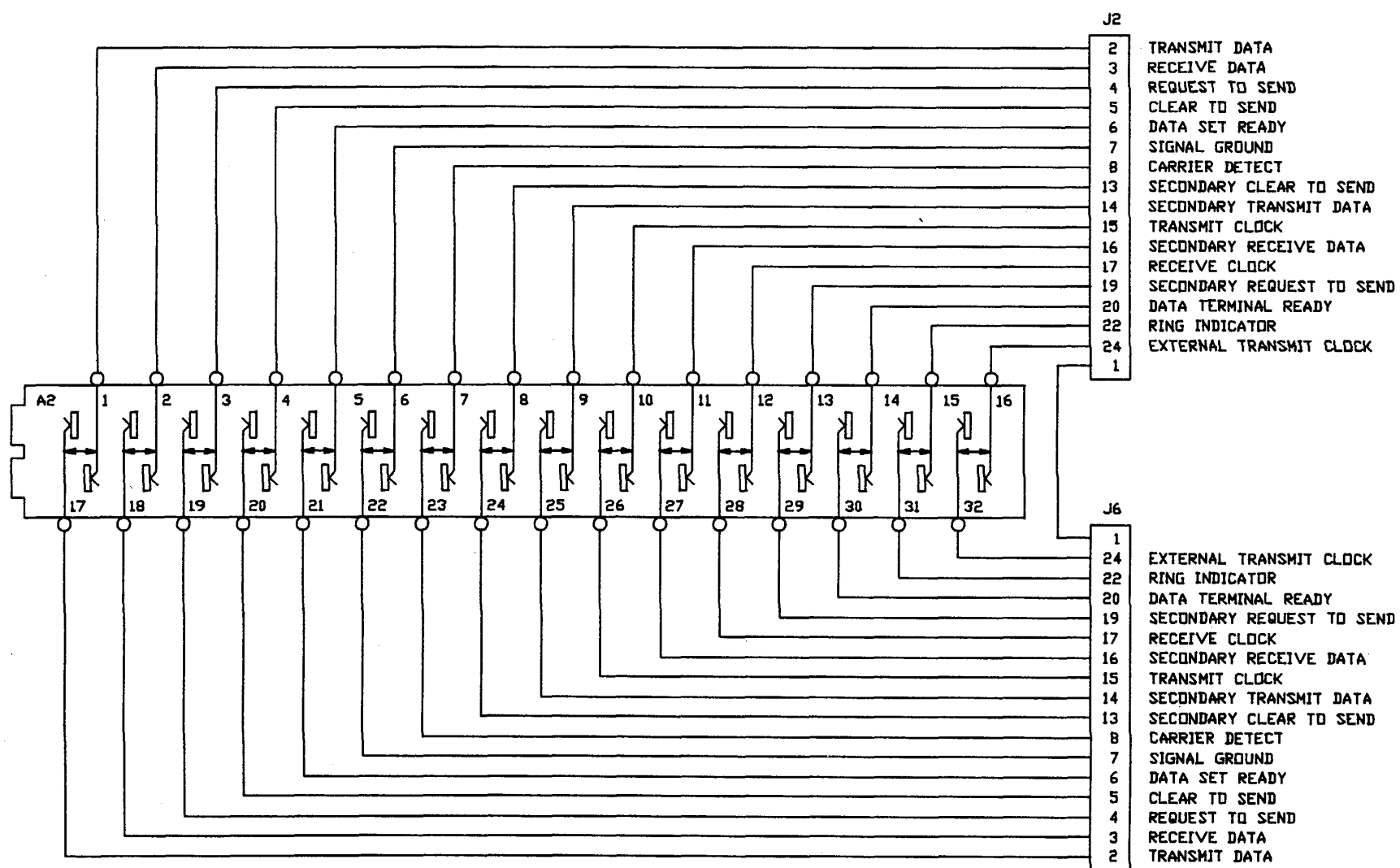

A3092772

Schematic Diagram, Red Patch Panel - OPN (Sheet 2 of 7)

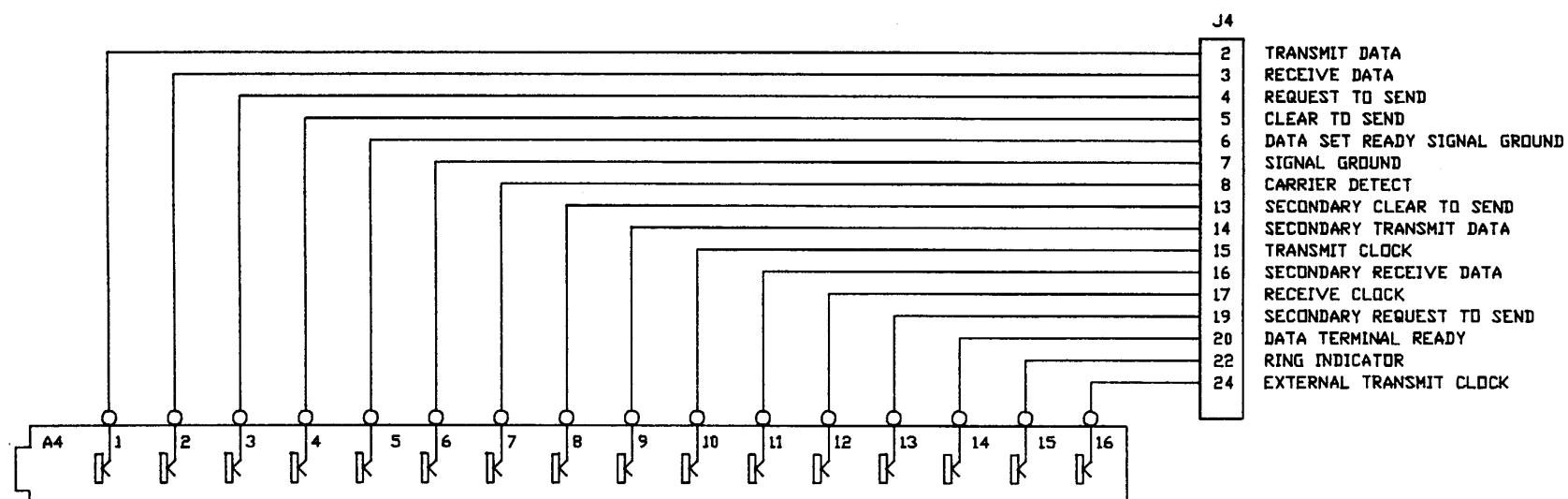
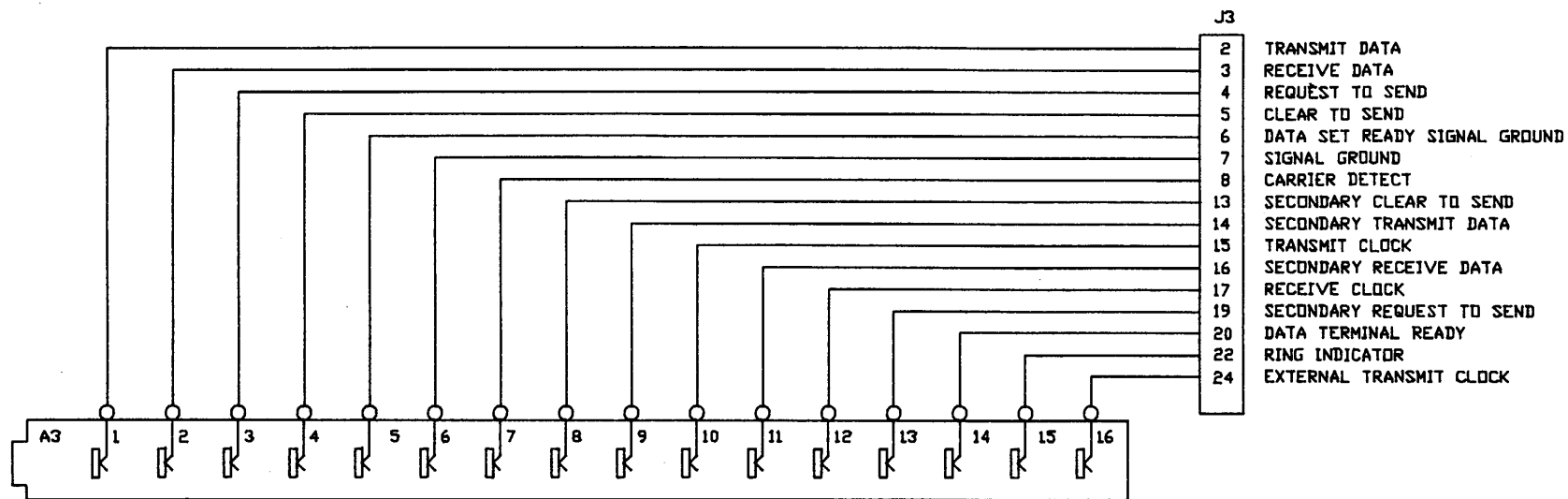

A3092772

Schematic Diagram, Red Patch Panel - OPN (Sheet 3 of 7)

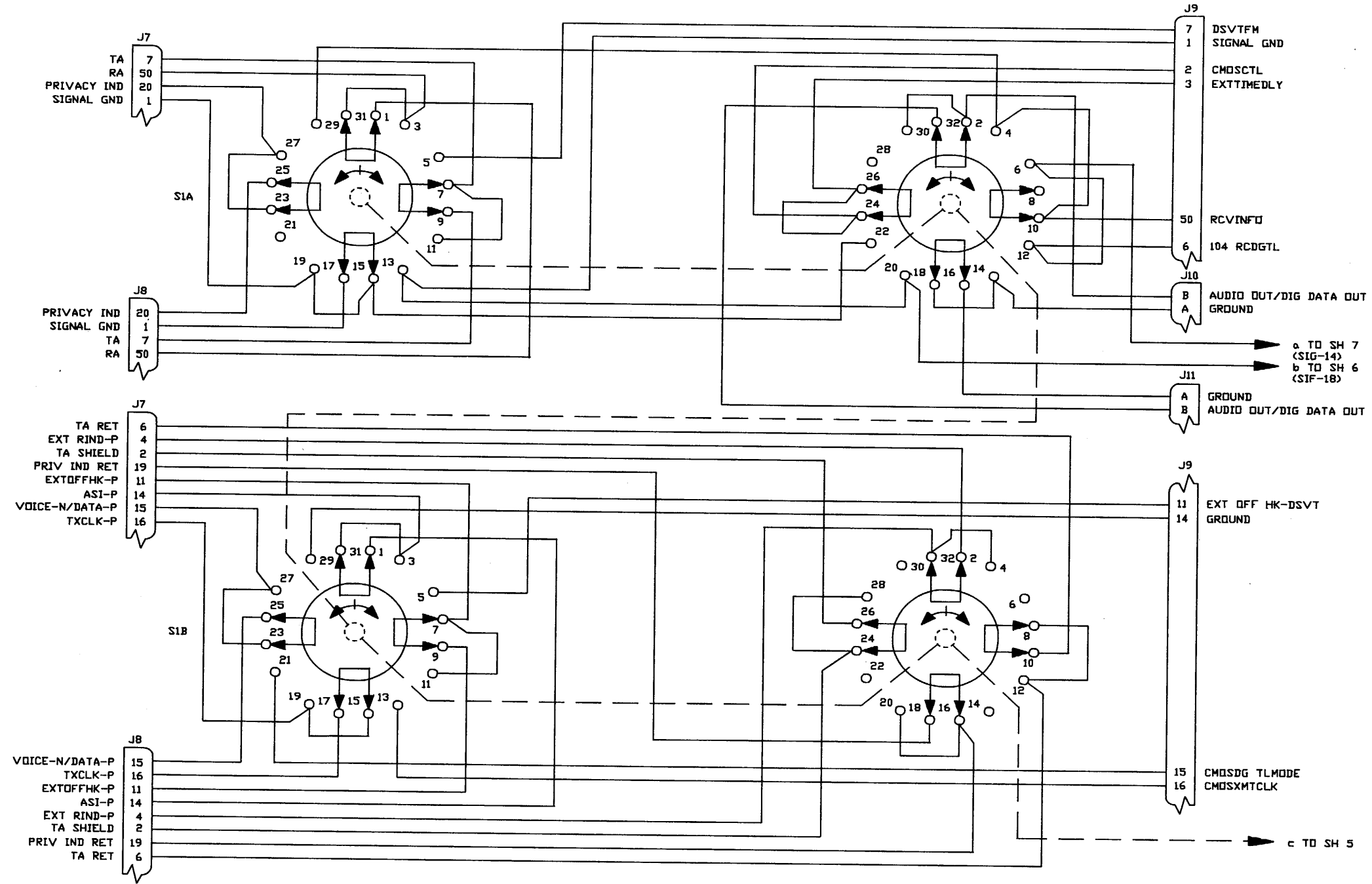

A3092772

Schematic Diagram, Red Patch Panel - OPN (Sheet 4 of 7)

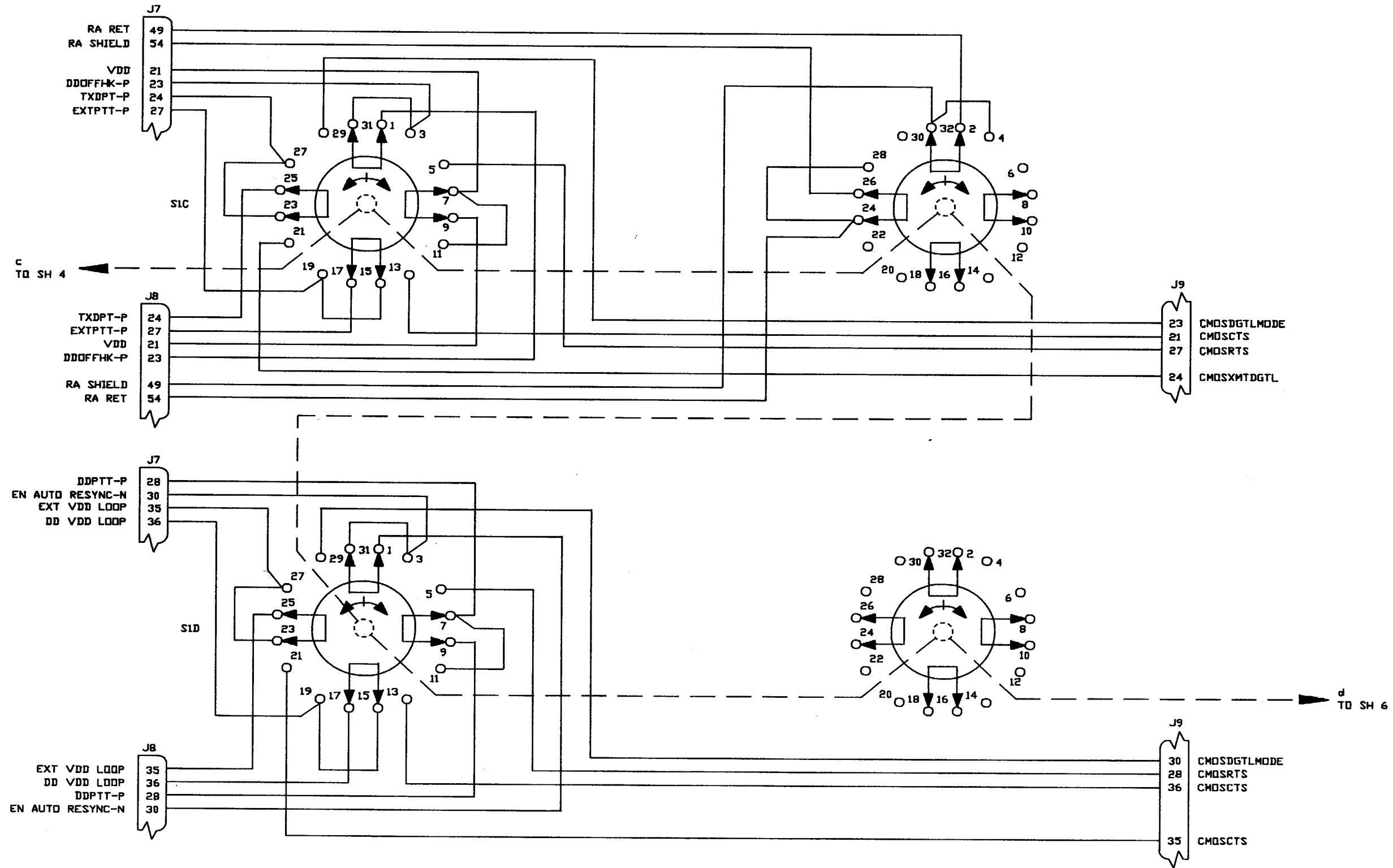

Schematic Diagram, Red Patch Panel - OPN (Sheet 5 of 7)

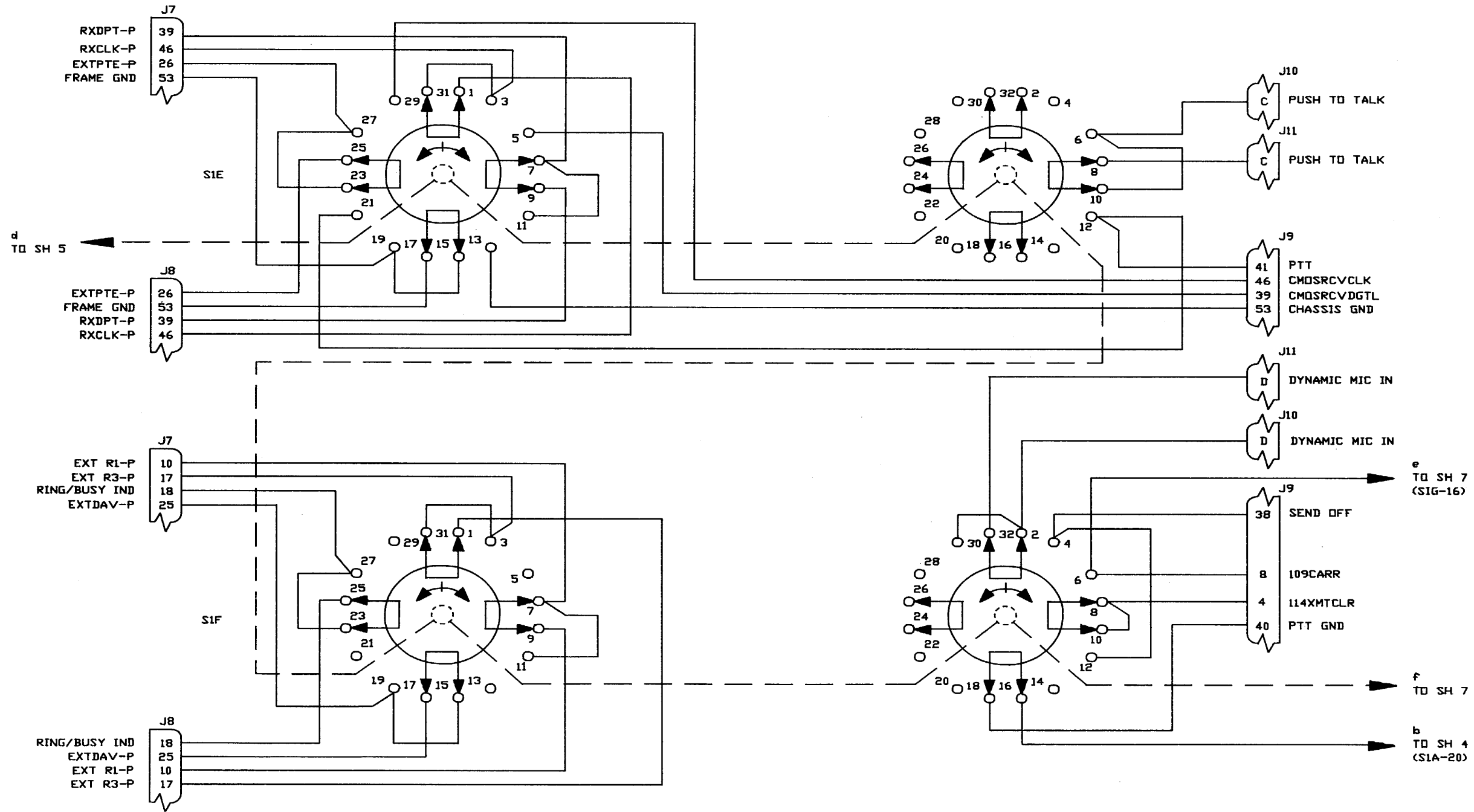

Schematic Diagram, Red Patch Panel - OPN (Sheet 6 of 7)

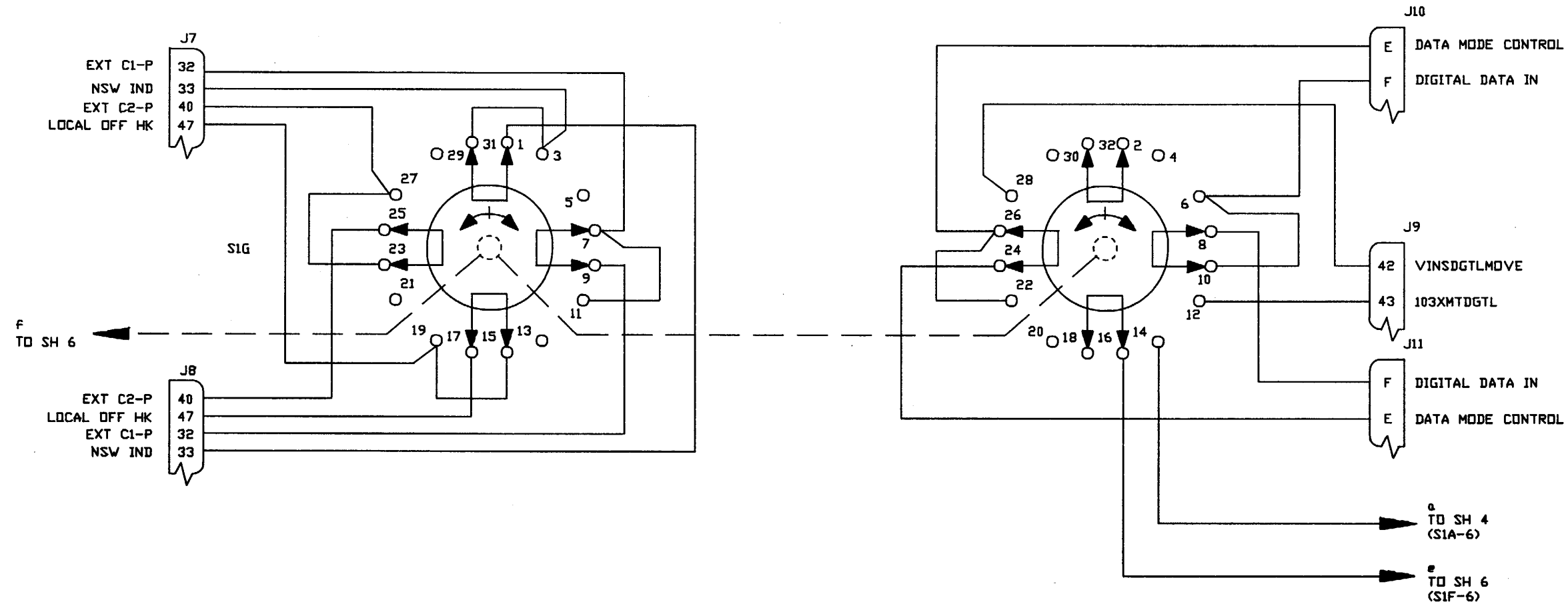

Schematic Diagram, Red Patch Panel - OPN (Sheet 7 of 7)

NOTES :

1. PARTIAL REFERENCE DESIGNATORS ARE SHOWN FOR COMPLETE REFERENCE DESIGNATION, PREFIX WITH UNIT NUMBER AND SUBASSEMBLY DESIGNATION.

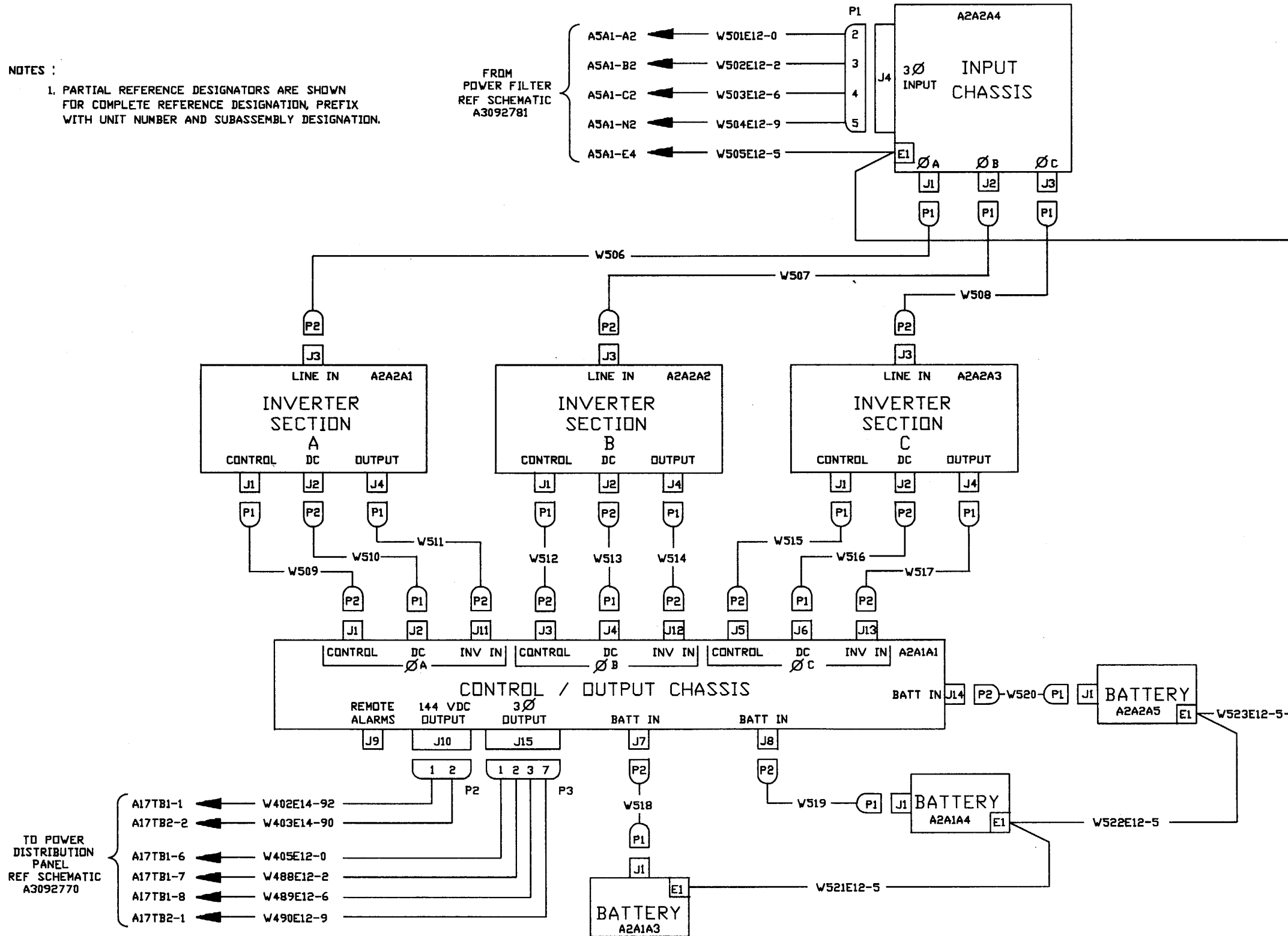

Schematic Diagram, Power Rack - OPN

PARTS LIST					
QTY	ITEM	PART NO.	DESCRIPTION	SPEC/STD	FSCM NO.
7	1 2 3	MS25036-112	TERMINAL LUG, RING, NO. 10, 12-10 AWG		96906
16	4	M2305315-104-9	HEAT SHRINKABLE WIRE MARKER	1 IN MIL-1-23053/5	81349
1	5 6 7 8	A3092921-2	CONNECTOR (P1)		80063
1	9	A3092918-2	BACKSHELL (P1)		80063
4	10 11	A3092919	CONTACT, SOCKET		80063
25	E12-0	M16878/4BLE0	WIRE, 12 AWG, BLACK	(FT) MIL-W-16878/4	81349
25	E12-2	M16878/4BLE2	WIRE, 12 AWG, RED	(FT) MIL-W-16878/4	81349
54.5	E12-5	M16878/4BLE5	WIRE, 12 AWG, GREEN	(FT) MIL-W-16878/4	81349
25	E12-6	M16878/4BLE6	WIRE, 12 AWG, BLUE	(FT) MIL-W-16878/4	81349
25	E12-9	M16878/4BLE9	WIRE, 12 AWG, WHITE	(FT) MIL-W-16878/4	81349

THIS DOCUMENT HAS BEEN PURCHASED BY THE GOVERNMENT AND MAY BE REPRODUCED AND USED IN CONNECTION WITH ANY GOVERNMENT PROCUREMENT OR MAINTENANCE OPERATION	SIZE A	FSCM NO. 80063	DRAWING NO. A392778
	SCALE NONE	LTR D	SHEET 3

WIRE NO. OR COLOR	FROM TERMINATION			TO TERMINATION			WIRE		FUNCTION	REMARKS
	REF DES	PIN	(I) ITEM (N) NOTE	REF DES	PIN	(I) ITEM (N) NOTE	ITEM	LENGTH		
W501E12-0	P1	2	110N3	A5AI		N2	E12-0	25 FT	PHASE A	BLACK
W502E12-2	P1	3	110N3	A5AI		N2	E12-2	25 FT	PHASE B	RED
W503E12-6	P1	4	110N3	A5AI		N2	E12-6	25 FT	PHASE C	BLUE
W504E12-9	P1	5	110N3	A5AI		N2	E12-9	25 FT	NEUTRAL	WHITE
W505E12-5	A5A1		N2	A1A3	EI	I1	E12-5	31 FT	GROUND	GREEN
W521E12-5	A1A3	EI	I1	A1A4	EI	I1	E12-5	7 FT	GROUND	GREEN
W522E12-5	A1A4	EI	I1	A2A5	EI	I1	E12-5	9.5 FT	GROUND	GREEN
W523E12-5	A2A5	EI	I1	A2A4	EI	I1	E12-5	7 FT	GROUND	GREEN

THIS DOCUMENT HAS BEEN PURCHASED BY THE GOVERNMENT AND MAY BE REPRODUCED AND USED IN CONNECTION WITH ANY GOVERNMENT PROCUREMENT OR MAINTENANCE OPERATION	SIZE A	FSCM NO. 80063	DRAWING NO. A3092778
	SCALE NONE	LTR B	SHEET 4

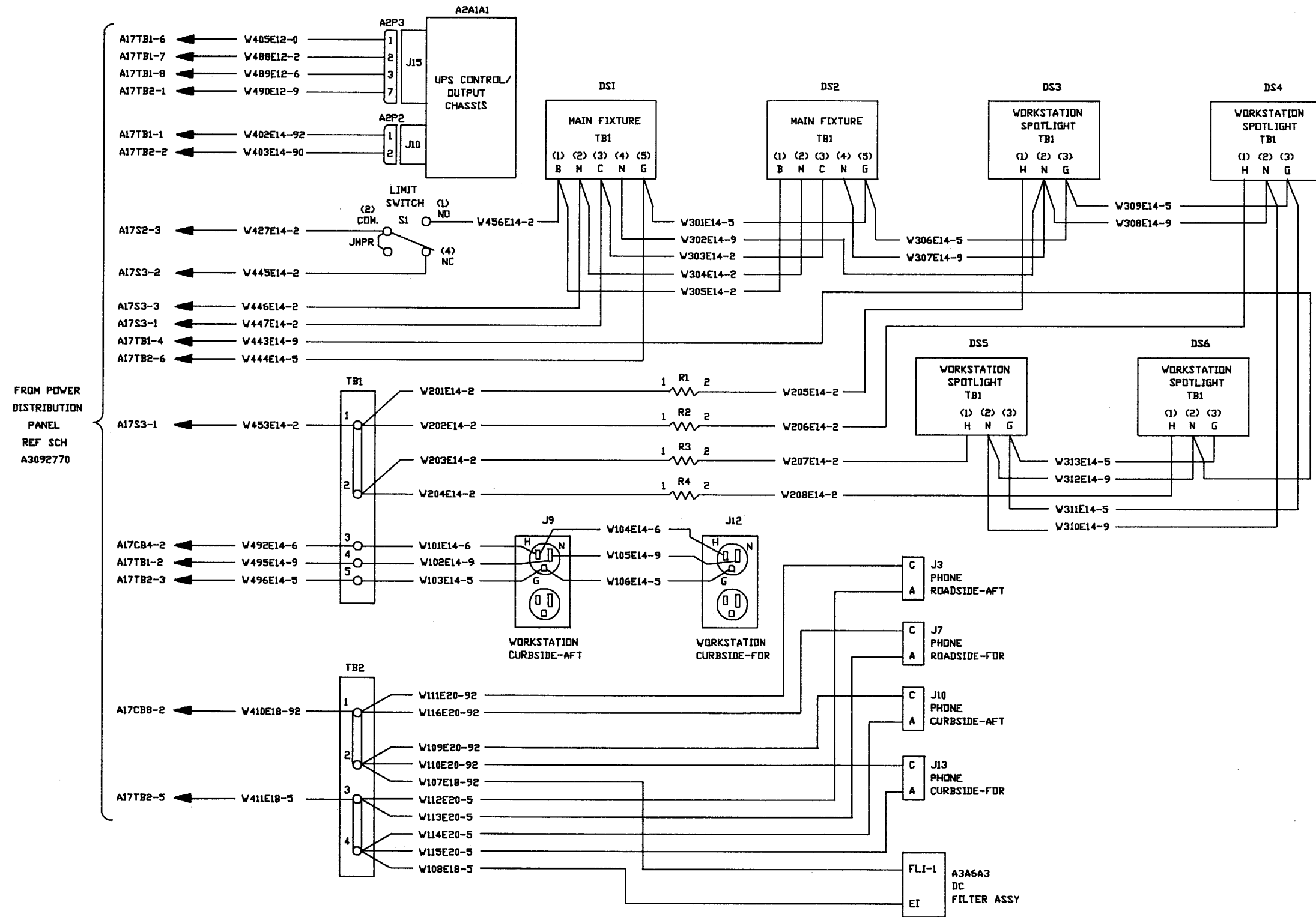

A3092781

Schematic Diagram, Shelter Power - OPN (Sheet 1 of 2)

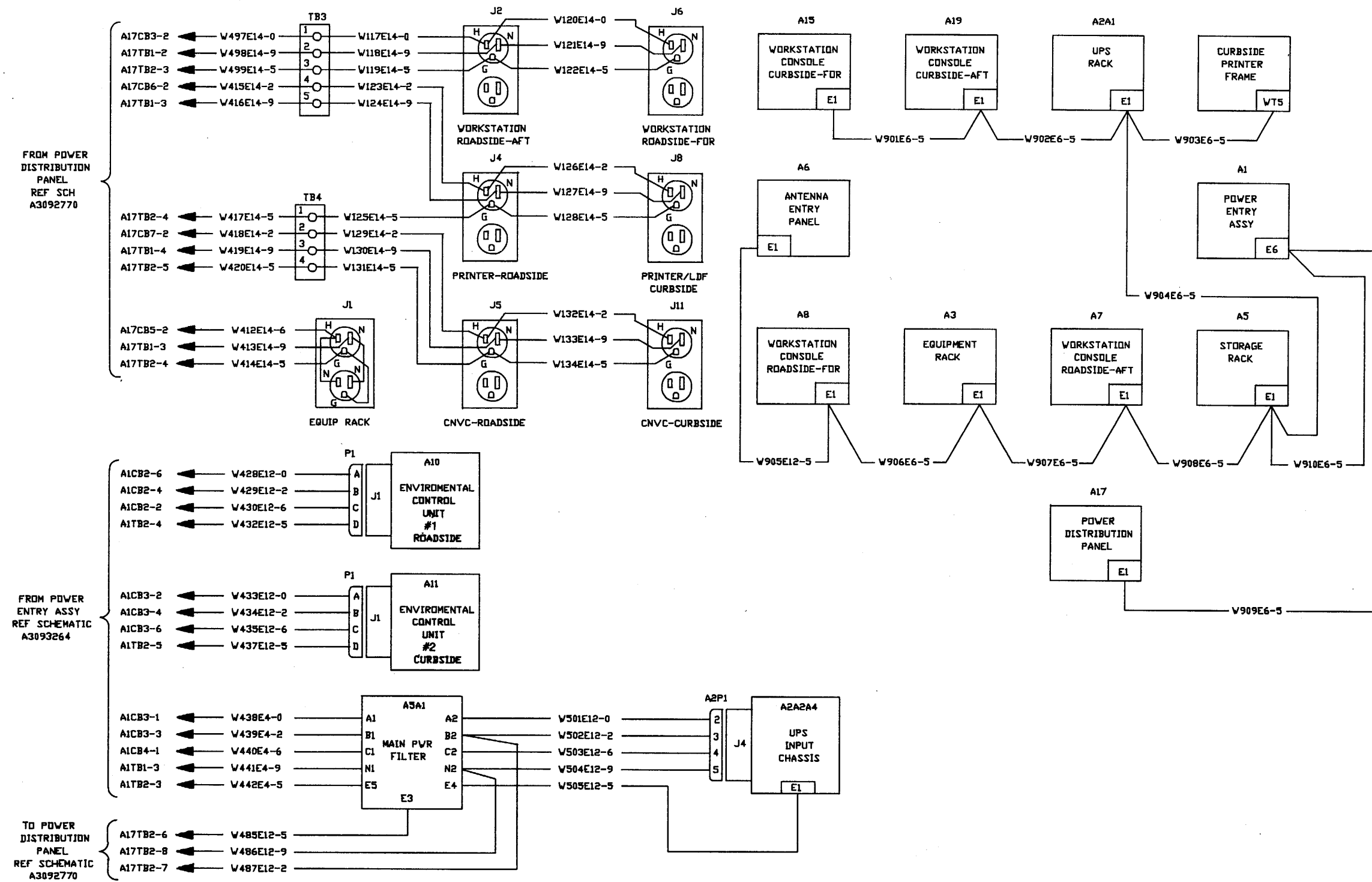

A3092781

Schematic Diagram, Shelter Power - OPN (Sheet 2 of 2)

NOTE: DATA MARKED WITH AN ASTERISK (*) IS PECULIAR TO A PRIOR MANUFACTURER. IT DOES NOT TAKE PRECEDENCE OVER ANY OTHER DATA ON THIS DRAWING, AND IS NOT CONTRACTUALLY BINDING ON EITHER THE CONTRACTOR OR THE GOVERNMENT.

THIS DOCUMENT HAS BEEN PURCHASED BY THE GOVERNMENT AND MAY BE REPRODUCED AND USED IN CONNECTION WITH ANY GOVERNMENT PROCUREMENT OR MAINTENANCE OPERATION.	REVISIONS																																																																																	
	<table border="1" style="width: 100%; border-collapse: collapse;"> <thead> <tr> <th style="width: 5%;">EFF</th> <th style="width: 5%;">LTR</th> <th style="width: 10%;">NO.</th> <th style="width: 55%;">DESCRIPTION</th> <th style="width: 10%;">DATE</th> <th style="width: 15%;">APPROVED</th> </tr> </thead> <tbody> <tr> <td>ALL</td> <td>A</td> <td></td> <td>INC ECN 92294, THESE SHEETS ADDED: 11 THRU 15</td> <td>88-05-27</td> <td>LC CP</td> </tr> <tr> <td>ALL</td> <td>B</td> <td></td> <td>INC ECN 93192</td> <td>88-08-03</td> <td>LC CP</td> </tr> <tr> <td>ALL</td> <td>C</td> <td></td> <td>INC ECN 93199</td> <td></td> <td>DD CP</td> </tr> <tr> <td>ALL</td> <td>D</td> <td></td> <td>INC ECN 97230</td> <td>87-06-01</td> <td>LC TB</td> </tr> <tr> <td></td> <td>E</td> <td></td> <td>INC ECN 104134, EFF: 89-04-19 ADDITION OF TEXT CHANGED SHEET COUNT FROM 17 TO 18.</td> <td>89-06-01</td> <td>DD TL</td> </tr> <tr> <td></td> <td>F</td> <td></td> <td>INC ECN 102401, EFF: 89-06-01</td> <td>89-07-10</td> <td>AH TB</td> </tr> <tr> <td></td> <td>G</td> <td></td> <td>INC ECN 115504, EFF: 89-07-13</td> <td>89-08-08</td> <td>AH KH</td> </tr> <tr> <td></td> <td>H</td> <td></td> <td>INC ECN 132203</td> <td>89-10-15</td> <td>LC</td> </tr> <tr> <td></td> <td>J</td> <td></td> <td>REPLACES REV H WITH CHANGES PER ECN 140612</td> <td>92-03-30</td> <td>MD 46 CP</td> </tr> </tbody> </table>	EFF	LTR	NO.	DESCRIPTION	DATE	APPROVED	ALL	A		INC ECN 92294, THESE SHEETS ADDED: 11 THRU 15	88-05-27	LC CP	ALL	B		INC ECN 93192	88-08-03	LC CP	ALL	C		INC ECN 93199		DD CP	ALL	D		INC ECN 97230	87-06-01	LC TB		E		INC ECN 104134, EFF: 89-04-19 ADDITION OF TEXT CHANGED SHEET COUNT FROM 17 TO 18.	89-06-01	DD TL		F		INC ECN 102401, EFF: 89-06-01	89-07-10	AH TB		G		INC ECN 115504, EFF: 89-07-13	89-08-08	AH KH		H		INC ECN 132203	89-10-15	LC		J		REPLACES REV H WITH CHANGES PER ECN 140612	92-03-30	MD 46 CP																					
EFF	LTR	NO.	DESCRIPTION	DATE	APPROVED																																																																													
ALL	A		INC ECN 92294, THESE SHEETS ADDED: 11 THRU 15	88-05-27	LC CP																																																																													
ALL	B		INC ECN 93192	88-08-03	LC CP																																																																													
ALL	C		INC ECN 93199		DD CP																																																																													
ALL	D		INC ECN 97230	87-06-01	LC TB																																																																													
	E		INC ECN 104134, EFF: 89-04-19 ADDITION OF TEXT CHANGED SHEET COUNT FROM 17 TO 18.	89-06-01	DD TL																																																																													
	F		INC ECN 102401, EFF: 89-06-01	89-07-10	AH TB																																																																													
	G		INC ECN 115504, EFF: 89-07-13	89-08-08	AH KH																																																																													
	H		INC ECN 132203	89-10-15	LC																																																																													
	J		REPLACES REV H WITH CHANGES PER ECN 140612	92-03-30	MD 46 CP																																																																													
<table border="1" style="width: 100%; border-collapse: collapse;"> <tr> <th style="width: 5%;">REV</th> <th style="width: 5%;">SHEET</th> <th style="width: 5%;">REV</th> <th style="width: 5%;">SHEET</th> <th style="width: 5%;">REV</th> <th style="width: 5%;">SHEET</th> <th style="width: 5%;">REV</th> <th style="width: 5%;">SHEET</th> <th style="width: 5%;">REV</th> <th style="width: 5%;">SHEET</th> <th style="width: 5%;">REV</th> <th style="width: 5%;">SHEET</th> <th style="width: 5%;">REV</th> <th style="width: 5%;">SHEET</th> <th style="width: 5%;">REV</th> <th style="width: 5%;">SHEET</th> <th style="width: 5%;">REV</th> <th style="width: 5%;">SHEET</th> <th style="width: 5%;">REV</th> <th style="width: 5%;">SHEET</th> </tr> <tr> <td></td><td></td><td></td><td></td><td></td><td></td><td></td><td></td><td></td><td></td><td></td><td></td><td></td><td></td><td></td><td></td><td></td><td></td><td></td><td></td><td></td> </tr> </table>	REV	SHEET	REV	SHEET	REV	SHEET	REV	SHEET	REV	SHEET	REV	SHEET	REV	SHEET	REV	SHEET	REV	SHEET	REV	SHEET																						<table border="1" style="width: 100%; border-collapse: collapse;"> <tr> <td style="width: 25%; padding: 5px;"> NOTES: 1. PREPARED IN ACCORDANCE WITH DOD-STD-100. 2. UNLESS OTHERWISE SPECIFIED, DIMENSIONS ARE IN INCHES. </td> <td style="width: 25%; padding: 5px; text-align: center;"> ELECTROSPACE SYSTEMS, INC. DAAB07-86-C-J008 </td> <td style="width: 50%; padding: 5px; text-align: center;"> U.S. ARMY COMMUNICATIONS - ELECTRONIC COMMAND FORT MONMOUTH, NEW JERSEY 07703 </td> </tr> <tr> <td style="padding: 5px;"> <table border="1" style="width: 100%; border-collapse: collapse;"> <tr> <th style="width: 10%;">APVD</th> <th style="width: 10%;">D. MORUE</th> <th style="width: 10%;">87-11-20</th> </tr> <tr> <td>ENGR</td> <td>M. MARTIN</td> <td>87-11-19</td> </tr> <tr> <td>ENGR</td> <td>C. PYBUS</td> <td>87-11-19</td> </tr> <tr> <td>CHECK</td> <td>C. REID</td> <td>87-11-20</td> </tr> <tr> <td>DRAWN</td> <td>L. CHATELAIN</td> <td>87-11-20</td> </tr> <tr> <td>REV</td> <td>P. PAO (ED-MX)</td> <td>9/30/92</td> </tr> <tr> <td>APVD</td> <td>R. RICCELLI (ED-MX)</td> <td></td> </tr> </table> </td> <td style="padding: 5px;"> <table border="1" style="width: 100%; border-collapse: collapse;"> <tr> <th style="width: 10%;">DRAWING TITLE</th> </tr> <tr> <td style="text-align: center;">WIRING LIST, POINT-TO-POINT, SHELTER POWER-OPN</td> </tr> </table> </td> </tr> <tr> <td style="padding: 5px;"> <table border="1" style="width: 100%; border-collapse: collapse;"> <tr> <th style="width: 10%;">SIZE</th> <th style="width: 10%;">FSCM NO.</th> <th style="width: 80%;">DRAWING NO.</th> </tr> <tr> <td style="text-align: center;">A</td> <td style="text-align: center;">80063</td> <td style="text-align: right;">A3092782</td> </tr> </table> </td> </tr> <tr> <td style="padding: 5px;"> <table border="1" style="width: 100%; border-collapse: collapse;"> <tr> <th style="width: 10%;">SCALE</th> <th style="width: 10%;">NONE</th> <th style="width: 10%;">J</th> <th style="width: 80%;">SHEET 1 OF 18</th> </tr> </table> </td> </tr> </table>	NOTES: 1. PREPARED IN ACCORDANCE WITH DOD-STD-100. 2. UNLESS OTHERWISE SPECIFIED, DIMENSIONS ARE IN INCHES.	ELECTROSPACE SYSTEMS, INC. DAAB07-86-C-J008	U.S. ARMY COMMUNICATIONS - ELECTRONIC COMMAND FORT MONMOUTH, NEW JERSEY 07703	<table border="1" style="width: 100%; border-collapse: collapse;"> <tr> <th style="width: 10%;">APVD</th> <th style="width: 10%;">D. MORUE</th> <th style="width: 10%;">87-11-20</th> </tr> <tr> <td>ENGR</td> <td>M. MARTIN</td> <td>87-11-19</td> </tr> <tr> <td>ENGR</td> <td>C. PYBUS</td> <td>87-11-19</td> </tr> <tr> <td>CHECK</td> <td>C. REID</td> <td>87-11-20</td> </tr> <tr> <td>DRAWN</td> <td>L. CHATELAIN</td> <td>87-11-20</td> </tr> <tr> <td>REV</td> <td>P. PAO (ED-MX)</td> <td>9/30/92</td> </tr> <tr> <td>APVD</td> <td>R. RICCELLI (ED-MX)</td> <td></td> </tr> </table>	APVD	D. MORUE	87-11-20	ENGR	M. MARTIN	87-11-19	ENGR	C. PYBUS	87-11-19	CHECK	C. REID	87-11-20	DRAWN	L. CHATELAIN	87-11-20	REV	P. PAO (ED-MX)	9/30/92	APVD	R. RICCELLI (ED-MX)		<table border="1" style="width: 100%; border-collapse: collapse;"> <tr> <th style="width: 10%;">DRAWING TITLE</th> </tr> <tr> <td style="text-align: center;">WIRING LIST, POINT-TO-POINT, SHELTER POWER-OPN</td> </tr> </table>	DRAWING TITLE	WIRING LIST, POINT-TO-POINT, SHELTER POWER-OPN	<table border="1" style="width: 100%; border-collapse: collapse;"> <tr> <th style="width: 10%;">SIZE</th> <th style="width: 10%;">FSCM NO.</th> <th style="width: 80%;">DRAWING NO.</th> </tr> <tr> <td style="text-align: center;">A</td> <td style="text-align: center;">80063</td> <td style="text-align: right;">A3092782</td> </tr> </table>	SIZE	FSCM NO.	DRAWING NO.	A	80063	A3092782	<table border="1" style="width: 100%; border-collapse: collapse;"> <tr> <th style="width: 10%;">SCALE</th> <th style="width: 10%;">NONE</th> <th style="width: 10%;">J</th> <th style="width: 80%;">SHEET 1 OF 18</th> </tr> </table>	SCALE	NONE	J	SHEET 1 OF 18
REV	SHEET	REV	SHEET	REV	SHEET	REV	SHEET	REV	SHEET	REV	SHEET	REV	SHEET	REV	SHEET	REV	SHEET	REV	SHEET																																																															
NOTES: 1. PREPARED IN ACCORDANCE WITH DOD-STD-100. 2. UNLESS OTHERWISE SPECIFIED, DIMENSIONS ARE IN INCHES.	ELECTROSPACE SYSTEMS, INC. DAAB07-86-C-J008	U.S. ARMY COMMUNICATIONS - ELECTRONIC COMMAND FORT MONMOUTH, NEW JERSEY 07703																																																																																
<table border="1" style="width: 100%; border-collapse: collapse;"> <tr> <th style="width: 10%;">APVD</th> <th style="width: 10%;">D. MORUE</th> <th style="width: 10%;">87-11-20</th> </tr> <tr> <td>ENGR</td> <td>M. MARTIN</td> <td>87-11-19</td> </tr> <tr> <td>ENGR</td> <td>C. PYBUS</td> <td>87-11-19</td> </tr> <tr> <td>CHECK</td> <td>C. REID</td> <td>87-11-20</td> </tr> <tr> <td>DRAWN</td> <td>L. CHATELAIN</td> <td>87-11-20</td> </tr> <tr> <td>REV</td> <td>P. PAO (ED-MX)</td> <td>9/30/92</td> </tr> <tr> <td>APVD</td> <td>R. RICCELLI (ED-MX)</td> <td></td> </tr> </table>	APVD	D. MORUE	87-11-20	ENGR	M. MARTIN	87-11-19	ENGR	C. PYBUS	87-11-19	CHECK	C. REID	87-11-20	DRAWN	L. CHATELAIN	87-11-20	REV	P. PAO (ED-MX)	9/30/92	APVD	R. RICCELLI (ED-MX)		<table border="1" style="width: 100%; border-collapse: collapse;"> <tr> <th style="width: 10%;">DRAWING TITLE</th> </tr> <tr> <td style="text-align: center;">WIRING LIST, POINT-TO-POINT, SHELTER POWER-OPN</td> </tr> </table>	DRAWING TITLE	WIRING LIST, POINT-TO-POINT, SHELTER POWER-OPN																																																										
APVD	D. MORUE	87-11-20																																																																																
ENGR	M. MARTIN	87-11-19																																																																																
ENGR	C. PYBUS	87-11-19																																																																																
CHECK	C. REID	87-11-20																																																																																
DRAWN	L. CHATELAIN	87-11-20																																																																																
REV	P. PAO (ED-MX)	9/30/92																																																																																
APVD	R. RICCELLI (ED-MX)																																																																																	
DRAWING TITLE																																																																																		
WIRING LIST, POINT-TO-POINT, SHELTER POWER-OPN																																																																																		
<table border="1" style="width: 100%; border-collapse: collapse;"> <tr> <th style="width: 10%;">SIZE</th> <th style="width: 10%;">FSCM NO.</th> <th style="width: 80%;">DRAWING NO.</th> </tr> <tr> <td style="text-align: center;">A</td> <td style="text-align: center;">80063</td> <td style="text-align: right;">A3092782</td> </tr> </table>	SIZE	FSCM NO.	DRAWING NO.	A	80063	A3092782																																																																												
SIZE	FSCM NO.	DRAWING NO.																																																																																
A	80063	A3092782																																																																																
<table border="1" style="width: 100%; border-collapse: collapse;"> <tr> <th style="width: 10%;">SCALE</th> <th style="width: 10%;">NONE</th> <th style="width: 10%;">J</th> <th style="width: 80%;">SHEET 1 OF 18</th> </tr> </table>	SCALE	NONE	J	SHEET 1 OF 18																																																																														
SCALE	NONE	J	SHEET 1 OF 18																																																																															

NOTES:

1. REFERENCE SCHEMATIC DIAGRAM A3092782.
2. RING LUG TERMINALS ARE CRIMPED USING M22520/5-01 TOOLING WITH M22520/5-100 DIE, PER MIL-C-22520.
3. WIRE IS PART OF WIRE HARNESS A3093528-2. THESE WIRES ARE ROUTED THROUGH CONDUIT TO THE ROADSIDE ENVIRONMENTAL CONTROL UNIT (A10). EACH WIRE IS TERMINATED TO A CONNECTOR PLUG (ITEM 20). TYPE ON ITEM 5 THE FOLLOWING:
 A3093528-2
 FSCM 80063
 M/H A10J2
 APPLY MARKER ON WIRE BUNDLE APPROXIMATELY TWO INCHES FROM CONNECTOR. SHRINK SLEEVING (ITEM 13) OVER EACH SOLDER CONNECTION.
4. EIGHT WIRES FROM POWER ENTRY ASSY (A1) EXIT THROUGH A ONE INCH DIAMETER OPENING AT THE BOTTOM OF THE ENCLOSURE. THESE WIRES ARE ROUTED THROUGH CONDUIT THAT RUNS ALONG THE ROADSIDE INTERIOR SHELTER WALL TO THE ECU'S. THE SHORTER FOUR WIRES END DESTINATION IS THE ROADSIDE ECU (A10). THE LONGER FOUR WIRES ARE ROUTED THROUGH A10 INTO ANOTHER RUN OF CONDUIT TO THE CURBSIDE ECU (A11). EACH SET OF WIRES SHALL BE SOLDERED TO A CABLE PLUG (ITEM 3) PER MIL-STD-454, REQUIREMENT 5. ON ITEM 5 TYPE THE FOLLOWING:

ECU POWER

M/W AXXJ1

 XX WILL BE EITHER 10 OR 11, DEPENDENT UPON THE LOCATION OF THE ECU. APPLY THE MARKER ON THE APPROPRIATE WIRE BUNDLE APPROXIMATELY TWO INCHES FROM THE CONNECTOR. THEN CONNECT CONNECTOR TO J1 OF THE ECU.
5. FIVE WIRES FROM THE POWER ENTRY ASSY EXIT THROUGH A 1 1/2 INCH DIAMETER OPENING AT THE BOTTOM OF THE ENCLOSURE. THESE FIVE WIRES ARE ROUTED IN CONDUIT TO THE POWER FILTER IN THE STORAGE RACK (A5).
6. WIRE HAS ONE END THAT IS CONNECTED IN THE POWER DISTRIBUTION ASSY (A17). THE OTHER END IS ROUTED OUT THE BOTTOM OPENING OF A17 INTO WIREMOLD RACEWAY.

THIS DOCUMENT HAS BEEN PURCHASED BY THE GOVERNMENT AND MAY BE REPRODUCED AND USED IN CONNECTION WITH ANY GOVERNMENT PROCUREMENT OR MAINTENANCE OPERATION	<table border="1" style="width: 100%; border-collapse: collapse;"> <tr> <th style="width: 50%;">SIZE</th> <th style="width: 50%;">FSCM NO.</th> </tr> <tr> <td style="text-align: center;">A</td> <td style="text-align: center;">80063</td> </tr> </table>	SIZE	FSCM NO.	A	80063	<table border="1" style="width: 100%; border-collapse: collapse;"> <tr> <th style="width: 100%;">DRAWING NO.</th> </tr> <tr> <td style="text-align: right;">A3092782</td> </tr> </table>	DRAWING NO.	A3092782
SIZE	FSCM NO.							
A	80063							
DRAWING NO.								
A3092782								
<table border="1" style="width: 100%; border-collapse: collapse;"> <tr> <th style="width: 50%;">SCALE</th> <th style="width: 50%;">NONE</th> </tr> </table>	SCALE	NONE	<table border="1" style="width: 100%; border-collapse: collapse;"> <tr> <th style="width: 25%;">LTR</th> <th style="width: 25%;">J</th> <th style="width: 25%;">SHEET</th> <th style="width: 25%;">2</th> </tr> </table>	LTR	J	SHEET	2	
SCALE	NONE							
LTR	J	SHEET	2					

NOTES (CONTINUED):

7. WIRE HAS ONE END THAT IS CONNECTED IN THE POWER DISTRIBUTION ASSY (A17). THE OTHER END IS ROUTED OUT THE TOP OPENING OF A17 INTO WIREMOLD RACEWAY.
8. TYPE APPROPRIATE "W" NUMBER ON EACH OF TWO 1 1/2 INCH LENGTHS OF SHRINK SLEEVING. SLIDE SLEEVE OVER WIRE BEFORE CRIMPING RING LUG. SHRINK TO WIRE APPROXIMATELY ONE INCH FROM EACH END. USE ITEM 12 FOR 20-18 AWG WIRE, ITEM 13 FOR 14-12 AWG WIRE, AND ITEM 14 FOR 6 AWG WIRE.
9. THIS NOTE INTENTIONALLY LEFT BLANK.
10. DUPLEX OUTLETS ARE PINNED OUT AS FOLLOWS:
THE HOT PIN (H) WILL BE THE GOLD SCREW, THE NEUTRAL PIN (N) WILL BE THE SILVER SCREW AND THE GROUND PIN (G) WILL BE THE GREEN OR CLEARLY MARKED AS THE GROUND TERMINAL.
11. CRIMP SOCKET CONTACTS WITH M22520/1 -02 TOOL, PER MIL-C-22520 INSERTION TOOL IS M81969/8-07, PER MIL-1-81969, EXTRACTION TOOL IS M81969/8-08, PER MIL-I-81969, PER MIL-I-81969. FILL UNUSED CONTACT POSITION (PIN B) WITH ADDITIONAL SOCKET CONTACT.
12. WIRE IS PART OF WIRE HARNESS A3093528-1. THESE WIRES ARE ROUTED THROUGH CONDUIT TO THE CURBSIDE ENVIRONMENTAL CONTROL UNIT (A11). EACH WIRE IS TERMINATED TO A CONNECTOR PLUG (ITEM 20). TYPE ON ITEM 5 THE FOLLOWING:

A3093528-1

FSCM 80063

M/W A11J2

APPLY MARKER ON WIRE BUNDLE APPROXIMATELY TWO INCHES FROM CONNECTOR. SHRINK SLEEVING (ITEM 13) OVER EACH SOLDER CONNECTION.

13. THIS WIRE END ALREADY CONNECTED AS PART OF ECU CONTROL HARNESS.

L-1	THIS DOCUMENT HAS BEEN PURCHASED BY THE GOVERNMENT AND MAY BE REPRODUCED AND USED IN CONNECTION WITH ANY GOVERNMENT PROCUREMENT OR MAINTENANCE OPERATION	SIZE A	FSCM NO. 80063	DRAWING NO. A3092782		
		SCALE	NONE	LTR	J	SHEET 3

NOTES (CONTINUED):

14. PARTS USAGE-

<u>REFERENCE DESIGNATOR</u>	<u>QTY</u>	<u>ITEM</u>	<u>DESCRIPTION</u>
A10J2, A11J2	2	20	CONNECTOR, ECU
ECU A10J1, A11J1	2	3	CONNECTOR, CIRCULAR
J3, J7, J10, J13	4	4	CONNECTOR, CIRCULAR
R1-R4	4	16	DIMMER, LIGHTING
A3J1, J2, J4-J6, J8, J9, J11, J12	9	17	OUTLET, DUPLEX

15. ONE END OF THESE WIRES IS ATTACHED TO THE POWER RACK BAY (A2). THE OTHER END IS ROUTED FROM THE REAR OF THE RACK INTO THE WIREMOLD RACEWAY TO THE OUTPUT SIDE OF THE POWER FILTER THAT IS LOCATED IN THE STORAGE RACK (A5).
16. W107 AND W108 EACH HAVE ONE END PREVIOUSLY TERMINATED AT DC FILTER BOX IN RACK A3. OTHER ENDS OF WIRES ARE ROUTED TO TB2.
17. GROUND STUD E3 IS THE UPPER RIGHT MOUNTING STUD FOR THE LEFT MOST FILTER (A PHASE FILTER). GROUND STUD E4 IS THE UPPER RIGHT MOUNTING STUD FOR THE FILTER LOCATED ADJACENT TO THE LEFT MOST FILTER (B PHASE FILTER)SEE FIGURE 1 FOR PICTORIAL LOCATION.
18. GROUND STUD E5 IS LOCATED IN THE SHIELDED COMPARTMENT ON THE POWER ENTRY SIDE OF THE FILTER. SEE FIGURE 1.
19. NO ASSEMBLY REQUIRED FOR WIRE END. WIRE IS ROUTED OUT BOTTOM OF POWER DISTRIBUTION ASSY TO POWER RACK. W485-W487 HAVE TERMINAL LUGS AND ARE CONNECTED TO POWER FILTER. W402 AND W403 ARE TERMINATED IN "P2" CONNECTOR. "P2" IS CONNECTED TO J10 OF UPS CONTROL CHASSIS. W405 AND W488-W490 ARE TERMINATED IN "P3" CONNECTOR. "P3" IS CONNECTED TO J15 OF UPS CONTROL CHASSIS. TERMINATE "P2" CONNECTOR USING ITEM 21, ITEM 22 AND ITEM 18. TERMINATE "P3" CONNECTOR USING ITEM 24, ITEM 23 AND ITEM. 18.
20. INSTALL ITEM NO. 25 ON TB1 - POSITIONS 1 AND 2. INSTALL ITEM NO. 25 ON TB2 - POSITIONS 1 AND 2; POSITIONS 3 AND 4.

THIS DOCUMENT HAS BEEN PURCHASED BY THE GOVERNMENT AND MAY BE REPRODUCED AND USED IN CONNECTION WITH ANY GOVERNMENT PROCUREMENT OR MAINTENANCE OPERATION	SIZE A	FSCM NO. 80063	DRAWING NO. A3092782		
	SCALE	NONE	LTR	J	SHEET 3

A3092782
WIRING LIST, POINT-TO-POINT, SHELTER POWER - OPN (Sheets 3 & 4 of 18)

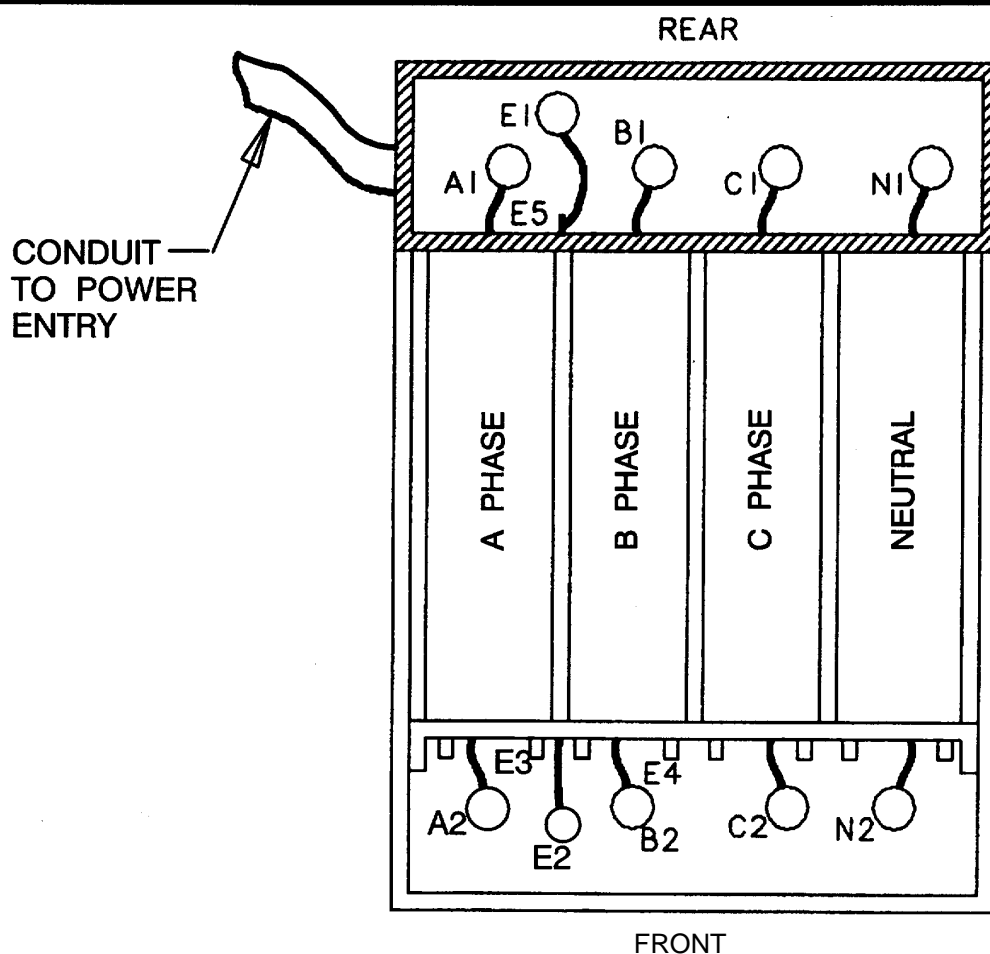

FIGURE 1 POWER FILTER

(3092782A)	THIS DOCUMENT HAS BEEN PURCHASED BY THE GOVERNMENT AND MAY BE REPRODUCED AND USED IN CONNECTION WITH ANY GOVERNMENT PROCUREMENT OR MAINTENANCE OPERATION	SIZE	FSCM NO.	DRAWING NO.	
		A	80063	A3092782	
		SCALE	NONE	LTR	J SHEET 5

PARTS LIST

QTY	ITEM	PART NO.	DESCRIPTION	SPEC/STD	FSCM NO.
31	1	MS25036-153	TERMINAL LUG, RING, NO. 8, 16-14 AWG		96906
1	2	MS25036-107	TERMINAL LUG, RING, NO. 6, 16-14 AWG		96906
2	3	MS3106R18-11 S	CONNECTOR, CIRCULAR		96906
4	4	MS27468T9B8S	CONNECTOR, CIRCULAR		96906
4	5	A3092925-4	CABLE MARKER (SEE NOTE 4)		80063
16	6	MS25036-119	TERMINAL LUG, RING, NO. 10, 6 AWG		96906
8	7	MS25036-112	TERMINAL LUG, RING, NO. 10, 12-10 AWG		96906
2	8	MS20659-143	TERMINAL LUG, RING, 1/2 INCH STUD, 6 AWG		96906
54	9	MS25036-108	TERMINAL LUG, RING, NO. 10, 16-14 AWG		96906
8	10	MS25036-103	TERMINAL LUG, RING, NO. 10, 22-18 AWG		96906
	11				
40	12	M23053/5-103-9	HEAT SHRINK SLEEVING, 3/32 DIA (IN)	MIL-I-23053/5	81349
144	13	M23053/5-104-9	HEAT SHRINK SLEEVING, 1/8 DIA (IN)	MIL-I-23053/5	81349
27	14	M23053/5-107-9	HEAT SHRINK SLEEVING, 3/8 DIA (IN)	MIL-I-23053/5	81349
8	15	M7928/3-3	SPLICE, CRIMP	MIL-T-7928/3	81349
4	16	A3092907	DIMMER, LIGHTING		80063
9	17	WC596/12-2	RECEPTACLE, OUTLET, DUPLEX MIL-STD-1353		96906

THIS DOCUMENT HAS BEEN PURCHASED BY THE GOVERNMENT AND MAY BE REPRODUCED AND USED IN CONNECTION WITH ANY GOVERNMENT PROCUREMENT OR MAINTENANCE OPERATION	SIZE	FSCM NO.	DRAWING NO.	
	A	80063	A3092782	
		SCALE	NONE	LTR J SHEET 6

PARTS LIST					
QTY	ITEM	PART NO.	DESCRIPTION	SPEC/STD	FSCM NO.
6	18	A3092928	CONTACT, PIN		80063
9	19	MS25036-157	TERMINAL, LUG, RING, 1/4 INCH, 12 AWG		96906
REF	20	A3105766	PLUG, REMOTE CONNECTOR - MODIFIED (A10P2, A11P2)		80063
1	21	A3092921-4	CONNECTOR, (P2)		80063
1	22	A3092918-1	BACKSHELL		80063
1	23	A3092921-3	CONNECTOR, (P3)		80063
1	24	A3092918-2	BACKSHELL		80063
AR	E14-90	M16878/4BKE90	WIRE, 14 AWG, WHITE/BLK	MIL-W-16878/4	81349
AR	E14-92	M16878/4BKE92	WIRE, 14 AWG, WHITE/RED	MIL-W-16878/4	81349
AR	E12-0	M16878/4BLE0	WIRE, 12 AWG, BLACK	MIL-W-16878/4	81349
AR	E12-6	M16878/4BLE6	WIRE, 12 AWG, BLUE	MIL-W-16878/4	81349
3	25	MS25266-4-2	BUS BAR, 2 HOLE		96906
5	26	MS25036-123	TERMINAL, LUG, RING, 1/4 INCH, 4 AWG		96906
6	27	MS25036-120	TERMINAL, LUG, RING, 1/4 INCH, 6 AWG		96906
AR	E6-5	M16878/12BPL5	WIRE, 6 AWG. GREEN	MIL-W-16878/12	81349

L-1	THIS DOCUMENT HAS BEEN PURCHASED BY THE GOVERNMENT AND MAY BE REPRODUCED AND USED IN CONNECTION WITH ANY GOVERNMENT PROCUREMENT OR MAINTENANCE OPERATION	SIZE	FSCM NO.	DRAWING NO.	
		A	80063	A 3092782	
		SCALE	NONE	LTR	J SHEET 7

PARTS LIST					
QTY	ITEM	PART NO.	DESCRIPTION	SPEC/STD	FSCM NO.
AR	E12-5	M16878/4BKE5	WIRE, 14 AWG, GREEN	MIL-W-16878/4	81349
AR	E14-2	M16878/4BKE0	WIRE, 14 AWG, BLACK	MIL-W-16878/4	81349
AR	E14-2	M16878/4BKE2	WIRE, 14 AWG, RED	MIL-W-16878/4	81349
AR	E14-5	M16878/4BKE5	WIRE, 14 AWG, GREEN	MIL-W-16878/4	81349
AR	E14-6	M16878/4BKE6	WIRE, 14 AWG, BLUE	MIL-W-16878/4	81349
AR	E14-9	M16878/4BKE9	WIRE, 14 AWG, WHITE	MIL-W-16878/4	81349
AR	E18-5	M16878/4BHE5	WIRE, 18 AWG, GREEN	MIL-W-16878/4	81349
AR	E18-92	M16878/4BHE92	WIRE, 18 AWG, WHITE/RED	MIL-W-16878/4	81349
AR	E20-5	M16878/4BGE5	WIRE, 20, GREEN	MIL-W-16878/4	81349
AR	E20-92	M16878/4BGE92	WIRE, 20 AWG, WHITE/RED	MIL-W-16878/4	81349
AR	E12-9	M16878/4BLE9	WIRE, 12 AWG, WHITE	MIL-W-16878/4	81349
AR	E12-2	M16878/4BLE2	WIRE, 12 AWG, RED	MIL-W-16878/4	81349

THIS DOCUMENT HAS BEEN PURCHASED BY THE GOVERNMENT AND MAY BE REPRODUCED AND USED IN CONNECTION WITH ANY GOVERNMENT PROCUREMENT OR MAINTENANCE OPERATION	SIZE	FSCM NO.	DRAWING NO.	
	A	80063	A3092771	
		SCALE	NONE	LTR J SHEET 8

WIRE NO. OR COLOR	FROM TERMINATION			TO TERMINATION			WIRE		FUNCTION	REMARKS
	REF DES	PIN	(I) ITEM (N) NOTE	REF DES	PIN	(I) ITEM (N) NOTE	ITEM	LENGTH		
W101E14-6	TB1	3	I9	J9	H	I9 N10	E14-6		PHASE C	BLUE
W102E14-9	TB1	4	I9	J9	N	I9 N10	E14-9		NEUTRAL	WHITE
W103E14-5	TB1	5	I9	J9	G	I1 N10	E14-5		GROUND	GREEN
W104E14-6	J9	H	I9 N10	J12	H	I9 N10	E14-6		PHASE C	BLUE
W105E14-	9	J9	N	I9 N10	J12	N	I9 N10	E14-9	NEUTRAL	WHITE
W106E14-5	J9	G	I1 N10	J12	G	I1 N10	E14-5		GROUND	GREEN
W107E18-92	TB2	2	N16			N16	E18-92		28 VDC	WHITE/RED
W108E18-5	TB2	4	N16			N16	E18-5		DC RTN	GREEN
W109E20-92	TB2	2	125110N20	J10	C		E20-92		28 VDC	WHITE/RED
W110E20-92	TB2	2	125110N20	J13	C		E20-92		28 VDC	WHITE/RED
W111E20-92	TB2	1	125110N20	J3	C		E20-92		28 VDC	WHITE/RED
W112E20-5	TB2	3	125110N20	J3	A		E20-5		DC RTN	GREEN
W113E20-5	TB2	3	125110N20	J7	A		E20-5		DC RTN	GREEN
W114E20-5	TB2	4	125110N20	J10	A		E20-5		DC RTN	GREEN
W115E20-5	TB2	4	125110N20	J13	A		E20-5		DC RTN	GREEN
W116E20-92	TB2	1	125110N20	J7	C		E20-92		28 VDC	WHITE/RED
W117E14-0	TB3	1	I9	J2	H	I9 N10	E14-0		PHASE A	BLACK

L-1	THIS DOCUMENT HAS BEEN PURCHASED BY THE GOVERNMENT AND MAY BE REPRODUCED AND USED IN CONNECTION WITH ANY GOVERNMENT PROCUREMENT OR MAINTENANCE OPERATION	SIZE	FSCM NO.	DRAWING NO.	
		A	80063	A3092782	
		SCALE	NONE	LTR	J SHEET 9

WIRE NO. OR COLOR	FROM TERMINATION			TO TERMINATION			WIRE		FUNCTION	REMARKS
	REF DES	PIN	(I) ITEM (N) NOTE	REF DES	PIN	(I) ITEM (N) NOTE	ITEM	LENGTH		
W118E14-9	TB3	2	I9	J2	N	I9 N10	E14-9		NEUTRAL	WHITE
W119E14-5	TB3	3	I9	J2	G	I1 N10	E14-5		GROUND	GREEN
W120E14-0	J2	H	I9 N10	J6	H	I9 N10	E14-0		PHASE A	BLACK
W121E14-9	J2	N	I9 N10	J6	N	I9 N10	E14-9		NEUTRAL	WHITE
W122E14-5	J2	G	I1 N10	J6	G	I1 N10	E14-5		GROUND	GREEN
W123E14-2	TB3	4	I9	J4	H	I9 N10	E14-2		PHASE B	RED
W124E14-9	TB3	5	I9	J4	N	I9 N10	E14-9		NEUTRAL	WHITE
W125E14-5	TB4	1	I9	J4	G	I1 N10	E14-5		GROUND	GREEN
W126E14-2	J4	H	I9 N10	J8	H	I9 N10	E14-2		PHASE B	RED
W127E14-9	J4	N	I9 N10	J8	N	I9 N10	E14-9		NEUTRAL	WHITE
W128E14-5	J4	G	I1 N10	J8	G	I1 N10	E14-5		GROUND	GREEN
W129E14-2	TB4	2	I9	J5	H	I9 N10	E14-2		PHASE B	RED
W130E14-9	TB4	3	I9	J5	N	I9 N10	E14-9		NEUTRAL	WHITE
W131E14-5	TB4	4	I9	J5	G	I1 N10	E14-5		GROUND	GREEN
W132E14-2	J5 -	H	I9 N10	J11	H	I9 N10	E14-2		PHASE B	RED
W133E14-9	J5	N	I9 N10	J11	N	I9 N10	E14-9		NEUTRAL	WHITE
W134E14-5	J5	G	I1 N10	J11	G	I1 N10	E14-5		GROUND	GREEN

THIS DOCUMENT HAS BEEN PURCHASED BY THE GOVERNMENT AND MAY BE REPRODUCED AND USED IN CONNECTION WITH ANY GOVERNMENT PROCUREMENT OR MAINTENANCE OPERATION	SIZE	FSCM NO.	DRAWING NO.	
	A	80063	A3092782	
		SCALE	NONE	LTR J SHEET 10

WIRE NO. OR COLOR	FROM TERMINATION			TO TERMINATION			WIRE		FUNCTION	REMARKS
	REF DES	PIN	(I) ITEM (N) NOTE	REF DES	PIN	(I) ITEM (N) NOTE	ITEM	LENGTH		
W201E14-2	TB1	1	I25 I9 N20 R1	1	115		E14-2		PHASE B	RED
W202E14-2	TB1	1	I25 I9 N20 R2	1	115		E14-2		PHASE B	RED
W203E14-2	TB1	2	I25 I9 N20 R3	1	115		E14-2		PHASE B	RED
W204E14-2	TB1	1	I9 N20 R4	1	115		E14-2		PHASE B	RED
W205E14-2	DS3TB1	1	I1	R2	2	115	E14-2		PHASE B	RED
W206E14-2	DS4TB1	1	I1	R2	2	115	E14-2		PHASE B	RED
W207E14-2	DS5TB1	1	I1	R3	2	115	E14-2		PHASE B	RED
W208E14-2	DS6TB1	1	I1	R4	2	115	E14-2		PHASE B	RED
W301 E14-5	DS1TB1	5	I9	DS2TB1	5	I9	E14-5		GROUND	GREEN
W302E14-9	DS1TB1	4	I9	DS3TB1	2	I9	E14-9		NEUTRAL	WHITE
W303E14-2	DS1TB1	3	I9	DS2TB1	3	I9	E14-2		PHASE B	RED
W304E14-2	DS1TB1	2	I9	DS2TB1	2	I9	E14-2		PHASE B	RED
W305E14-2	DS1TB1	1	I9	DS2TB1	1	I9	E14-2		PHASE B	RED
W306E14-5	DS3TB1	3	I1	DS2TB1	5	I9	E14-5		GROUND	GREEN
W307E14-9	DS3TB1	2	I1	DS2TB1	4	I9	E14-9		NEUTRAL	WHITE
W308E14-9	DS3TB1	2	I1	DS4TB1	2	I1	E14-9		NEUTRAL	WHITE

L-1	THIS DOCUMENT HAS BEEN PURCHASED BY THE GOVERNMENT AND MAY BE REPRODUCED AND USED IN CONNECTION WITH ANY GOVERNMENT PROCUREMENT OR MAINTENANCE OPERATION	SIZE	FSCM NO.	DRAWING NO.	
		A	80063	A3092782	
		SCALE	NONE	LTR	J SHEET 11

WIRE NO. OR COLOR	FROM TERMINATION			TO TERMINATION			WIRE		FUNCTION	REMARKS
	REF DES	PIN	(I) ITEM (N) NOTE	REF DES	PIN	(I) ITEM (N) NOTE	ITEM	LENGTH		
W309E14-5	DS3TB1	3	I1	DS4TB1	3	11	E14-5		GROUND	GREEN
W310E14-9	DS4TB1	2	I1	DS5TB1	2	11	E14-9		NEUTRAL	WHITE
W311E14-5	DS4TB1	3	I1	DS5TB1	3	11	E14-5		GROUND	GREEN
W312E14-9	DS5TB1	2	I1	DS6TB1	2	11	E14-9		NEUTRAL	WHITE
W313E14-5	DS5TB1	3	I1	DS6TB1	3	11	E14-5		GROUND	GREEN
W402E14-92	A17TB1	1	I7	A2A1A1P21		N19	E14-92		144 VDC	WHT/RED
W403E14-90	A17TB2	2	I7	A2A1A1P22		N19	E14-90		DC COMMON	WHT/BLK
W405E12-0	A17TB1	6	I7	A2A1A1P31		N19	E12-0		PHASE A	BLACK
W410E18-92			N7	TB2	1				28 VDC	WHT/RED
W411 E18-5			N7	TB2	3				GROUND	GREEN
W412E14-6			N7	A3J1	H	I9 N10	E14-6		PHASE C	BLUE
W413E14-9			N7	A3J1	N	I9 N10	E14-9		NEUTRAL	WHITE
W414E14-5			N7	A3J1	G	I1 N10	E14-5		GROUND	GREEN
W415E14-2			N6	TB3	4				PHASE B	RED
W416E14-9			N6	TB3	5				NEUTRAL	WHITE
W417E14-5			N6	TB4	1				GROUND	GREEN
W418E14-2			N6	TB4	2				PHASE B	RED

THIS DOCUMENT HAS BEEN PURCHASED BY THE GOVERNMENT AND MAY BE REPRODUCED AND USED IN CONNECTION WITH ANY GOVERNMENT PROCUREMENT OR MAINTENANCE OPERATION	SIZE	FSCM NO.	DRAWING NO.	
	A	80063	A3092782	
		SCALE	NONE	LTR J SHEET 12

A3092782

WIRE NO. OR COLOR	FROM TERMINATION			TO TERMINATION			WIRE		FUNCTION	REMARKS
	REF DES	PIN	(I) ITEM (N) NOTE	REF DES	PIN	(I) ITEM (N) NOTE	ITEM	LENGTH		
W419E14-9			N6	TB4	3				NEUTRAL	WHITE
W420E14-5			N6	TB4	4				GROUND	GREEN
W427E14-2			N6	S1	2				PHASE B	RED
W428E12-0			N4	A10P1	A	I3 N4			PHASE A	BLACK
W429E12-2			N4	A10P1	B	I3 N4			PHASE B	RED
W430E12-6			N4	A10P1	C	I3 N4			PHASE C	BLUE
W432E12-5			N4	A10P1	D	I3 N4			GROUND	GREEN
W433E12-0			N4	A11P1	A	I3 N4			PHASE A	BLACK
W434E12-2			N4	A11P1	B	I3 N4			PHASE B	RED
W435E12-6			N4	A11P1	C	I3 N4			PHASE C	BLUE
W437E12-5			N4	A11P1	D	I3 N4			GROUND	GREEN
W438E4-0			N5 I25	A5A1	A1	N5			PHASE A	BLACK
W439E4-2			N5 I26	A5A1	B1	N5			PHASE B	RED
W440E4-6				N5 I26	A5A1	C1	N5		PHASE C	BLUE
W441 E4-9				N5 I26	A5A1	N1	N5		NEUTRAL	WHITE
W442E4-5				N5 I26	A5A1	E5	N5 N18		GROUND	GREEN
W443E14-9			N7	DS6TB1	2				NEUTRAL	WHITE

L-1	THIS DOCUMENT HAS BEEN PURCHASED BY THE GOVERNMENT AND MAY BE REPRODUCED AND USED IN CONNECTION WITH ANY GOVERNMENT PROCUREMENT OR MAINTENANCE OPERATION	SIZE	FSCM NO.	DRAWING NO.			
		A	80063	A3092782			
		SCALE	NONE	LTR	J	SHEET	13

WIRE NO. OR COLOR	FROM TERMINATION			TO TERMINATION			WIRE		FUNCTION	REMARKS
	REF DES	PIN	(I) ITEM (N) NOTE	REF DES	PIN	(I) ITEM (N) NOTE	ITEM	LENGTH		
W444E14-5			N7	DS1TB1	5				GROUND	GREEN
W445E14-2			N6	S1	4				PHASE B	RED
W446E14-2			N7	DS1TB1	2				PHASE B	RED
W447E14-2			N7	DS1TB1	3				PHASE B	RED
W448E14-2	S1	2	I2	S1	3	12	E14-2		PHASE B	RED
W453E14-2			N7	TB1	1				PHASE B	RED
W456E14-2	DS1TB1	1	19	S1	1	I2	E14-2		PHASE B	RED
W485E12-5	A5A1	E3	I19 N17	A17TB2	6	N6	E12-5		GROUND	GREEN
W486E12-9	A5A1	N2	I19	A17TB2	8	N6	E12-9		NEUTRAL	WHITE
W487E12-2	A5A1	B2	I19	A17TB2	7	N6	E12-2		PHASE B	RED
W488E12-2	A17TB1	7	I7	A2A1A1P32		N19	E12-2		PHASE B	RED
W489E12-6	A17TB1	8	I7	A2A1A1P33		N19	E12-6		PHASE C	BLUE
W490 E12-9	A17TB2	1	I7	A2A1A1P37		N19	E12-9		NEUTRAL	WHITE
W492E14-6			N7	TB1	3				PHASE C	BLUE
W495E14-9			N7	TB1	4				NEUTRAL	WHITE
W496E14-5			N7	TB1	5				GROUND	GREEN
W497E14-0			N6	TB3	1				PHASE A	BLACK
W498 E14-9			N6	TB3	2				NEUTRAL	WHITE

THIS DOCUMENT HAS BEEN PURCHASED BY THE GOVERNMENT AND MAY BE REPRODUCED AND USED IN CONNECTION WITH ANY GOVERNMENT PROCUREMENT OR MAINTENANCE OPERATION	SIZE	FSCM NO.	DRAWING NO.			
	A	80063	A3092782			
	SCALE	NONE	LTR	J	SHEET	13

WIRE NO. OR COLOR	FROM TERMINATION			TO TERMINATION			WIRE		FUNCTION	REMARKS
	REF DES	PIN	(I) ITEM (N) NOTE	REF DES	PIN	(I) ITEM (N) NOTE	ITEM	LENGTH		
W499E14-5			N6	TB3	3	N14			GROUND	GREEN
W501E12-0			N15	A5A1	A2	I19			PHASE A	BLACK
W502E12-2			N15	A5A1	B2	I19			PHASE B	RED
W503E12-6			N15	A5A1	C2	I19			PHASE C	BLUE
W504E12-9			N15	A5A1	N2	I19			NEUTRAL	WHITE
W505E12-5			N15	A5A1	E4	I19 N17			GROUND	GREEN
W901E6-5	A15E1		I27	A19E1		I27	E6-5	36	GND BUS	GREEN
W902E6-5	A19E1		I27	A2A1E1		I6	E6-5	108	GND BUS	GREEN
W903E6-5	A2A1E1		I6	WT5		I6	E6-5	72	GND BUS	GREEN
W904E6-5	A2A1E1		I6	A5E1		I6	E6-5	143	GND BUS	GREEN
W905E12-5	A6E1		I7	A8E1		I19	E12-5	108	GND BUS	GREEN
W906E6-5	A8E1		I27	A3E1		I6	E6-5	156	GND BUS	GREEN
W907E6-5	A3E1		I6	A7E1		I27	E6-5	146	GND BUS	GREEN
W908E6-5	A7E1		I27	A5E1		I6	E6-5	120	GND BUS	GREEN
W909E6-5	A17E1		I6	A1E6		I8	E6-5	72	GND BUS	GREEN
W910E6-5	A5E1		I6	A1E6		I8	E6-5	42	GND BUS	GREEN
91			N13	A10P2	A1	I20 N3			ECU CONTROL	WHITE/BROWN

L-1	THIS DOCUMENT HAS BEEN PURCHASED BY THE GOVERNMENT AND MAY BE REPRODUCED AND USED IN CONNECTION WITH ANY GOVERNMENT PROCUREMENT OR MAINTENANCE OPERATION	SIZE	FSCM NO.	DRAWING NO.			
		A	80063	A6092782			
		SCALE	NONE	LTR	J	SHEET	15

WIRE NO. OR COLOR	FROM TERMINATION			TO TERMINATION			WIRE		FUNCTION	REMARKS
	REF DES	PIN	(I) ITEM (N) NOTE	REF DES	PIN	(I) ITEM (N) NOTE	ITEM	LENGTH		
92			N13	A10P2	A2	I20 N3			ECU CONTROL	WHITE/RED
95			N13	A10P2	A3	I20 N3			ECU CONTROL	WHITE/GREEN
906			N13	A10P2	A4	I20 N3			ECU CONTROL	WHITE/BLK/BLU
905			N13	A10P2	A5	I20 N3			ECU CONTROL	WHITE/BLK/GRN
98			N13	A10P2	A6	I20 N3			ECU CONTROL	WHITE/GRAY
901			N13	A10P2	A7	I20 N3			ECU CONTROL	WHITE/BLK/BRN
94			N13	A10P2	A8	I20 N3			ECU CONTROL	WHITE/YELLOW
93			N13	A10P2	A9	I20 N3			ECU CONTROL	WHITE/ORANGE
4			N13	A10P2	A11	I20 N3			ECU CONTROL	YELLOW
0			N13	A10P2	A12	I20 N3			ECU CONTROL	BLACK
2			N13	A10P2	A13	I20 N3			ECU CONTROL	RED
6			N13	A10P2	A14	I20 N3			ECU CONTROL	BLUE
5			N13	A10P2	A15	I20 N3			ECU CONTROL	GREEN
9			N13	A10P2	A16	I20 N3			ECU CONTROL	WHITE
8			N13	A10P2	B2	I20 N3			ECU CONTROL	GRAY
908			N13	A10P2	B3	I20 N3			ECU CONTROL	WHITE/BLK/GRA
907			N13	A10P2	B4	I20 N3			ECU CONTROL	WHITE/BLK/VIO

L-1	THIS DOCUMENT HAS BEEN PURCHASED BY THE GOVERNMENT AND MAY BE REPRODUCED AND USED IN CONNECTION WITH ANY GOVERNMENT PROCUREMENT OR MAINTENANCE OPERATION	SIZE	FSCM NO.	DRAWING NO.			
		A	80063	A3092782			
		SCALE	NONE	LTR	J	SHEET	16

WIRE NO. OR COLOR	FROM TERMINATION			TO TERMINATION			WIRE		FUNCTION	REMARKS
	REF DES	PIN	(I) ITEM (N) NOTE	REF DES	PIN	(I) ITEM (N) NOTE	ITEM	LENGTH		
914			N13	A10P2	B5	I20 N3			ECU CONTROL	WHITE/BRN/YEL
96			N13	A10P2	B6	I20 N3			ECU CONTROL	WHITE/BLUE
7			N13	A10P2	B7	I20 N3			ECU CONTROL	VIOLET
913			N13	A10P2	B8	I20 N3			ECU CONTROL	WHITE/BRN/ORN
90			N13	A10P2	B9	I20 N3			ECU CONTROL	WHITE/BLACK
912			N13	A10P2	B10	I20 N3			ECU CONTROL	WHITE/BRN/RED
3			N13	A10P2	B11	I20 N3			ECU CONTROL	ORANGE
91			N13	A11P2	A1	I20 N12			ECU CONTROL	WHITE/BROWN
92			N13	A11P2	A2	I20 N12			ECU CONTROL	WHITE/RED
95			N13	A11P2	A3	I20 N12			ECU CONTROL	WHITE/GREEN
906			N13	A11P2	A4	I20 N12			ECU CONTROL	WHITE/BLK/BLU
905			N13	A11P2	A5	I20 N12			ECU CONTROL	WHITE/BLK/GRN
98			N13	A11P2	A6	I20 N12			ECU CONTROL	WHITE/GRAY
901			N13	A11P2	A7	I20 N12			ECU CONTROL	WHITE/BLK/BRN
94			N13	A11P2	A8	I20 N12			ECU CONTROL	WHITE/YELLOW
93			N13	A11P2	A9	I20 N12			ECU CONTROL	WHITE/ORANGE
4			N13	A11P2	A11	I20 N12			ECU CONTROL	YELLOW

L-1	THIS DOCUMENT HAS BEEN PURCHASED BY THE GOVERNMENT AND MAY BE REPRODUCED AND USED IN CONNECTION WITH ANY GOVERNMENT PROCUREMENT OR MAINTENANCE OPERATION	SIZE	FSCM NO.	DRAWING NO.	
		A	80063	A3092782	
		SCALE	NONE	LTR	J
				SHEET	17

WIRE NO. OR COLOR	FROM TERMINATION			TO TERMINATION			WIRE		FUNCTION	REMARKS
	REF DES	PIN	(I) ITEM (N) NOTE	REF DES	PIN	(I) ITEM (N) NOTE	ITEM	LENGTH		
0			N13	A11P2	A12	I20 N12			ECU CONTROL	BLACK
2			N13	A11P2	A13	I20 N12			ECU CONTROL	RED
6			N13	A11P2	A14	I20 N12			ECU CONTROL	BLUE
5			N13	A11P2	A15	I20 N12			ECU CONTROL	GREEN
9			N13	A11P2	A16	I20 N12			ECU CONTROL	WHITE
8			N13	A11P2	B2	I20 N12			ECU CONTROL	GRAY
908			N13	A11P2	B3	I20 N12			ECU CONTROL	WHITE/BLK/GRA
907			N13	A11P2	B4	I20 N12			ECU CONTROL	WHITE/BLK/VIO
914			N13	A11P2	B5	I20 N12			ECU CONTROL	WHITE/BRN/YEL
96			N13	A1 P2	B6	I20 N12			ECU CONTROL	WHITE/BLUE
7			N13	A11P2	B7	I20 N12			ECU CONTROL	VIOLET
913			N13	A11P2	B8	I20 N12			ECU CONTROL	WHITE/BRN/ORN
90			N13	A11P2	B9	I20 N12			ECU CONTROL	WHITE/BLACK
912			N13	A11P2	B10	I20 N12			ECU CONTROL	WHITE/BRN/RED
3			N13	A11P2	B11	I20 N12			ECU CONTROL	ORANGE

THIS DOCUMENT HAS BEEN PURCHASED BY THE GOVERNMENT AND MAY BE REPRODUCED AND USED IN CONNECTION WITH ANY GOVERNMENT PROCUREMENT OR MAINTENANCE OPERATION	SIZE	FSCM NO.	DRAWING NO.		
	A	80063	A3092782		
		SCALE	NONE	LTR	J
				SHEET	18

NOTES :

1. PARTIAL REFERENCE DESIGNATORS ARE SHOWN FOR COMPLETE REFERENCE DESIGNATION, PREFIX WITH UNIT NUMBER AND SUBASSEMBLY DESIGNATION.

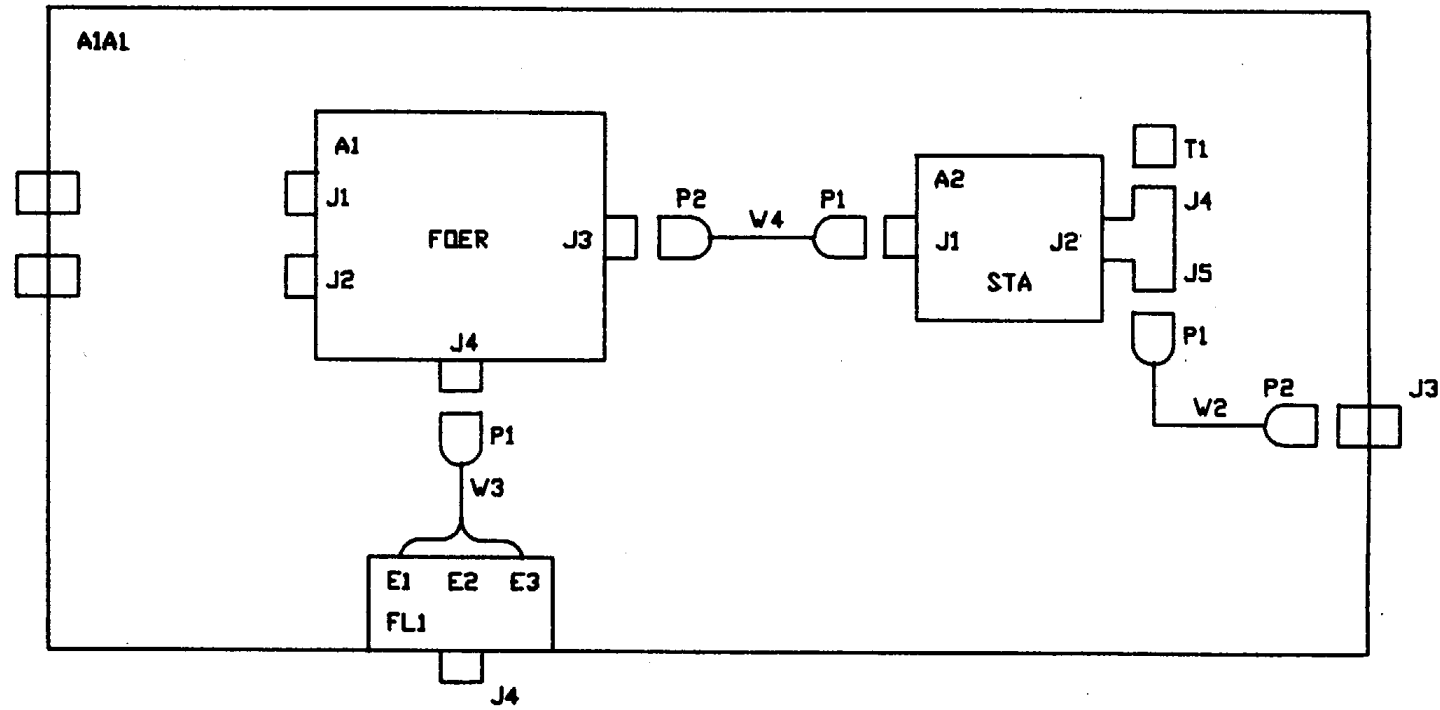

A3092862

A3092862
 Interconnection Diagram, Repeater/Station Adapter

NOTES :

1. IDENTIFY PART PER MIL-STD-130, TAG.
2. WORKMANSHIP SHALL BE IN ACCORDANCE WITH MIL-STD-454, REQUIREMENT 9.
3. DIMENSIONAL DATA IS BASED ON AMERICAN NATIONAL STANDARD ANSI Y14.5-1973.
4. CRIMP INSERTION TOOL NO. M81969/8-07, REMOVAL TOOL NO. M81969/8-08, PER MIL-I-81969.
5. CRIMPING TOOL NO. M22520/1-01 WITH M22520/1-04 BL TURRET, PER MIL-C-22520.
6. EACH CONDUCTOR SHALL BE TESTED FOR CONTINUITY AND CORRECT CONNECTIONS BETWEEN ITS TERMINATIONS, USING A POTENTIAL OF NOT MORE THAN 10 VOLTS. CONTINUITY CHECKS SHALL BE MADE FROM CONNECTOR CONTACT TO CONNECTOR CONTACT USING A CONTINUITY TESTER. CONTINUITY POINTS SHALL BE OBTAINED FROM THE CABLE WIRING DIAGRAM. WHERE SHIELD IS BONDED TO CONNECTOR ON BOTH ENDS, THE SHIELD CONTINUITY SHALL BE CHECKED FROM CONNECTOR SHELL TO CONNECTOR SHELL.
7. INSULATION RESISTANCE SHALL BE IN ACCORDANCE WITH METHOD 302 OF MIL-STD-202, TEST CONDITION B. THE POTENTIAL SHALL BE APPLIED BETWEEN EACH CONDUCTOR AND THE REMAINING CONDUCTORS CONNECTED TOGETHER AND TO THE SHIELD, AND CONNECTOR. THE INSULATION RESISTANCE OF THE CABLE ASSEMBLY SHALL NOT BE LESS THAN 100 MEGOHMS. EXCEPT THE INSULATION RESISTANCE OF A SHIELDED CONDUCTOR SHALL NOT BE LESS THAN 30 MEGOHMS.
8. DIELECTRIC WITHSTAND VOLTAGE. DIELECTRIC STRENGTH SHALL BE PERFORMED IN ACCORDANCE WITH METHOD 301 OF MIL-STD-202. A POTENTIAL OF 500 VOLTS DC SHALL BE APPLIED FOR 30 SECONDS MINIMUM. THE POTENTIAL SHALL BE APPLIED BETWEEN EACH CONDUCTOR AND THE REMAINING CONDUCTORS CONNECTED TOGETHER AND TO THE SHIELD AND CONNECTOR.
9. PARTIAL REFERENCE DESIGNATION ARE SHOWN. FOR COMPLETE REFERENCE DESIGNATION, PREFIX WITH UNIT NUMBER AND SUBASSEMBLY DESIGNATION.

△ ALL UNUSED POSITIONS IN CONNECTOR P2 ARE TO BE FILLED WITH CONTACTS.

11. DETETED
- △12 ALL SHIELDS MUST TERMINATE INSIDE OF EMI BACKSHELL.
13. TRIM FIND NO. 2 TO LENGTH ON CABLE PROFILE.
- △14 TOLERANCE ON CABLE LENGTH SHALL BE +2, -1 INCHES.
- △15 DIMENSIONS SHOWN ON CABLE PREPARATION ILLUSTRATION ARE FOR REFERENCE ONLY.
16. VENDOR ITEM, SEE SPECIFICATION CONTROL DRAWING.

1	12	96906	MS27467T15B5S	CONNECTOR, ELECTRICAL			
	11						
1	10	81349	M85049/37-14W03L	BACKSHELL, EMI/RFI	MIL-C-85049/37		
	9						
5	8	81349	M39029/56-352	CONTACT, CRIMP, SOCKET	MIL-C-39029/56		
	7						
	6						
REF	5	80063	A3092728	TEST PROCEDURE/DATA SHEET POWER AND SIGNAL CABLE TEST			
	4						
	3						
1	2	80063	A3092927-1	CABLE ASSEMBLY, MOLDED CONNECTOR			13 , 16
	1						
QTY REQD.	FIND NO.	FSCM NO.	PART NUMBER OR IDENTIFYING NO.	NOMENCLATURE OR DESCRIPTION	SPEC/STD	SHEET NO.	NOTE
PARTS LIST							

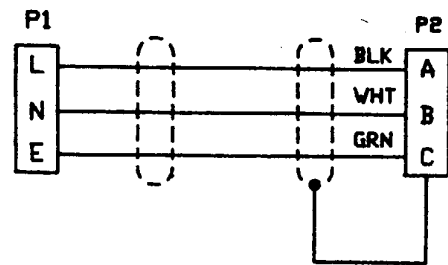
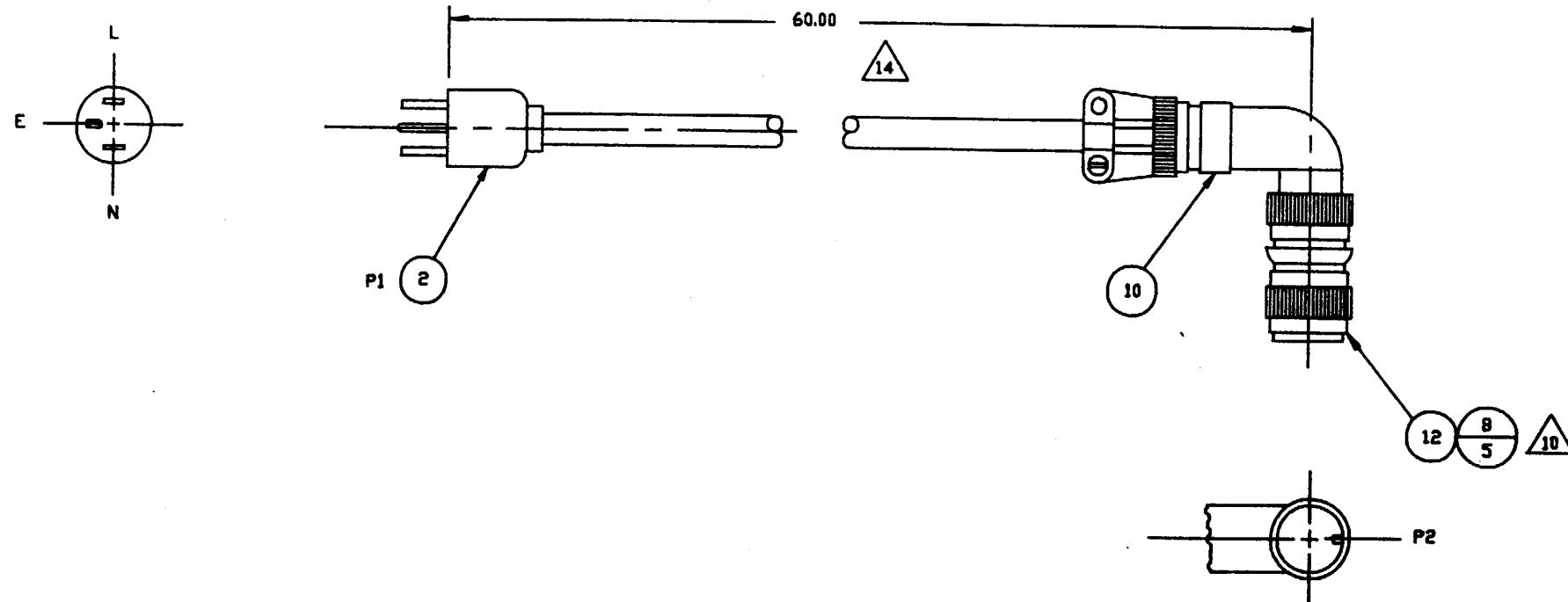

WIRING DIAGRAM

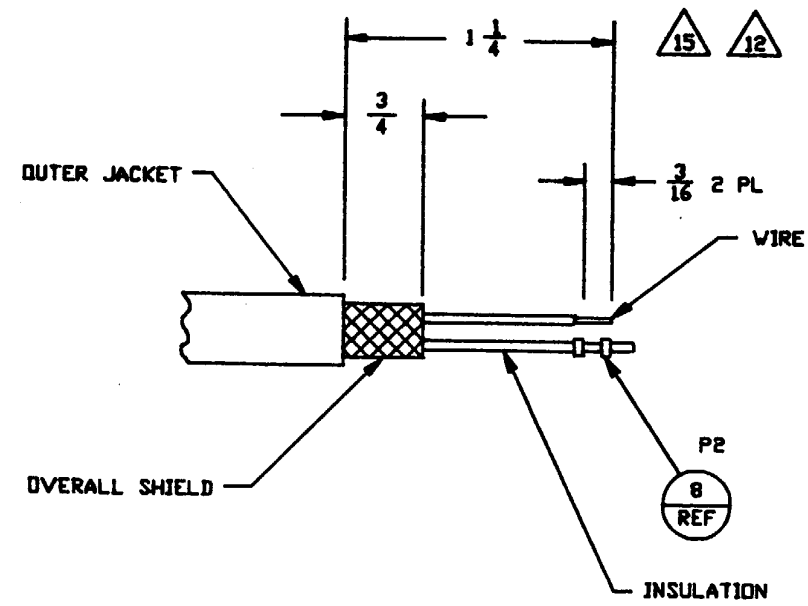

CABLE PREPARATION
SCALE : NONE
P2 END

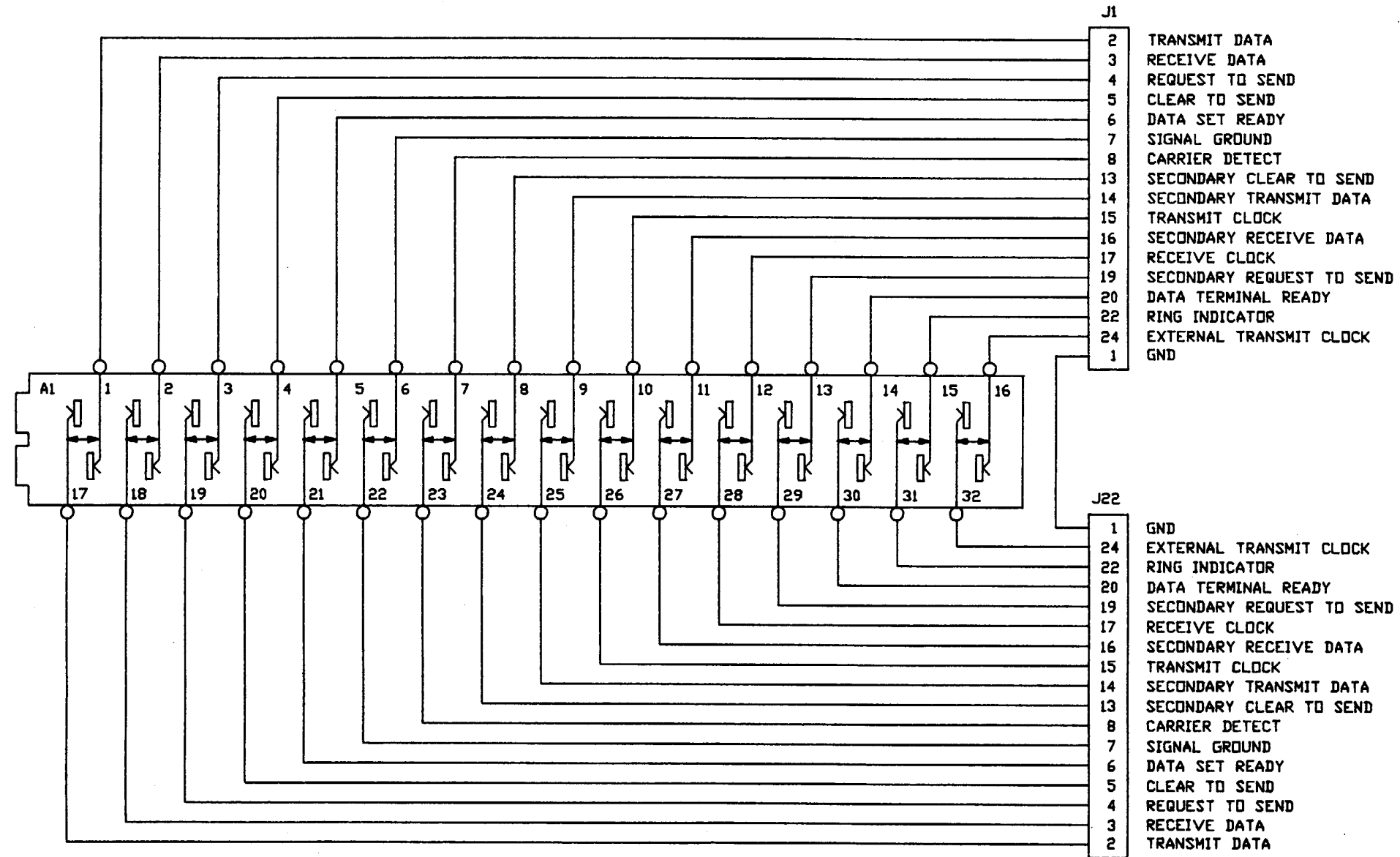

NOTES :

1. PARTIAL REFERENCE DESIGNATIONS ARE SHOWN.
FOR COMPLETE REFERENCE DESIGNATION, PREFIX WITH UNIT NUMBER AND SUBASSEMBLY DESIGNATION.
2. ALL UNUSED POSITIONS IN CONNECTORS J1-J43 WILL BE FILLED WITH CONTACTS.
3. # DENOTES LOWER CASE LETTERS.
4. J42 NOT USED.

A3093161

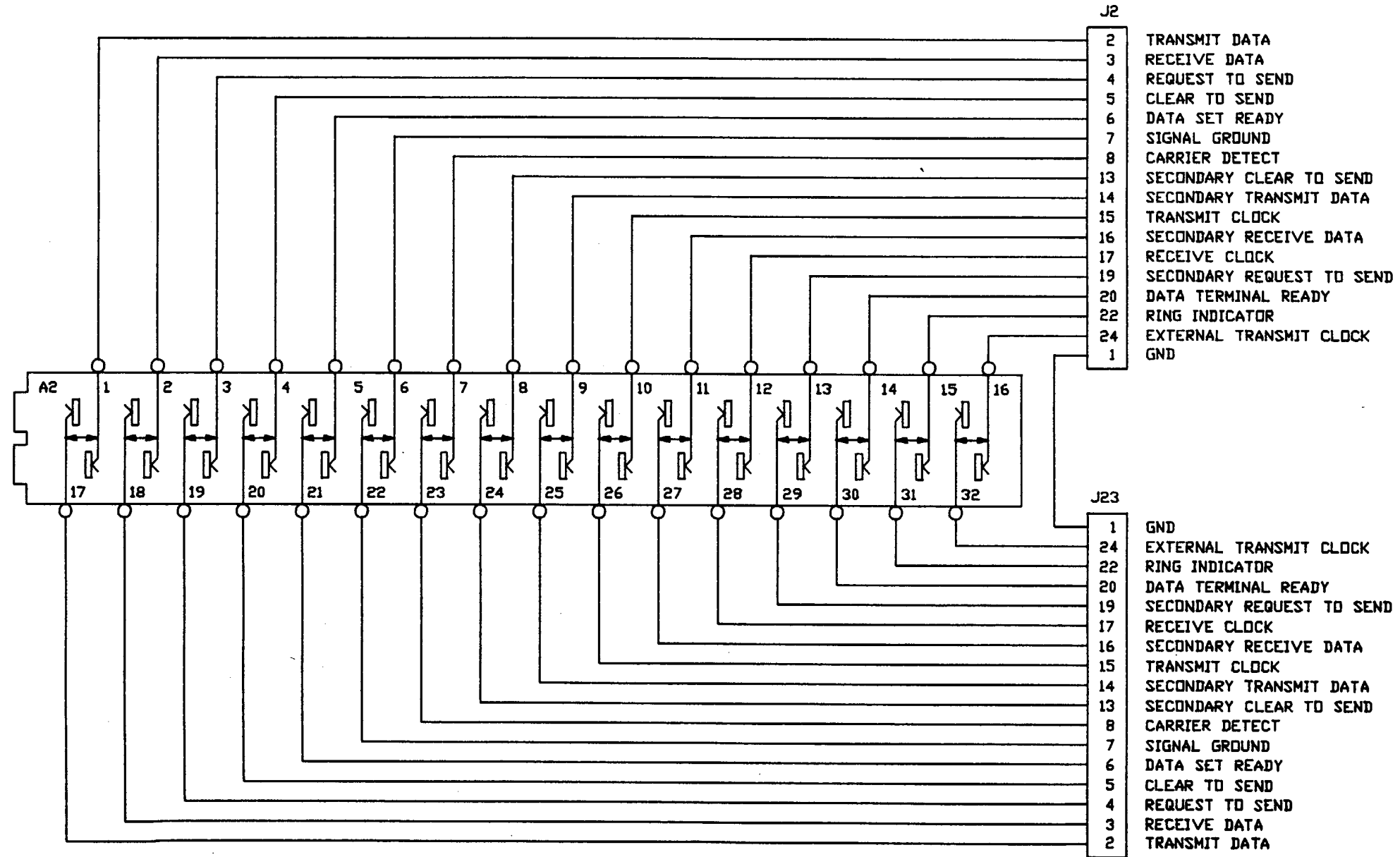

A3093161

Schematic Diagram, Patch Panel - Red (Sheet 2 of 22)

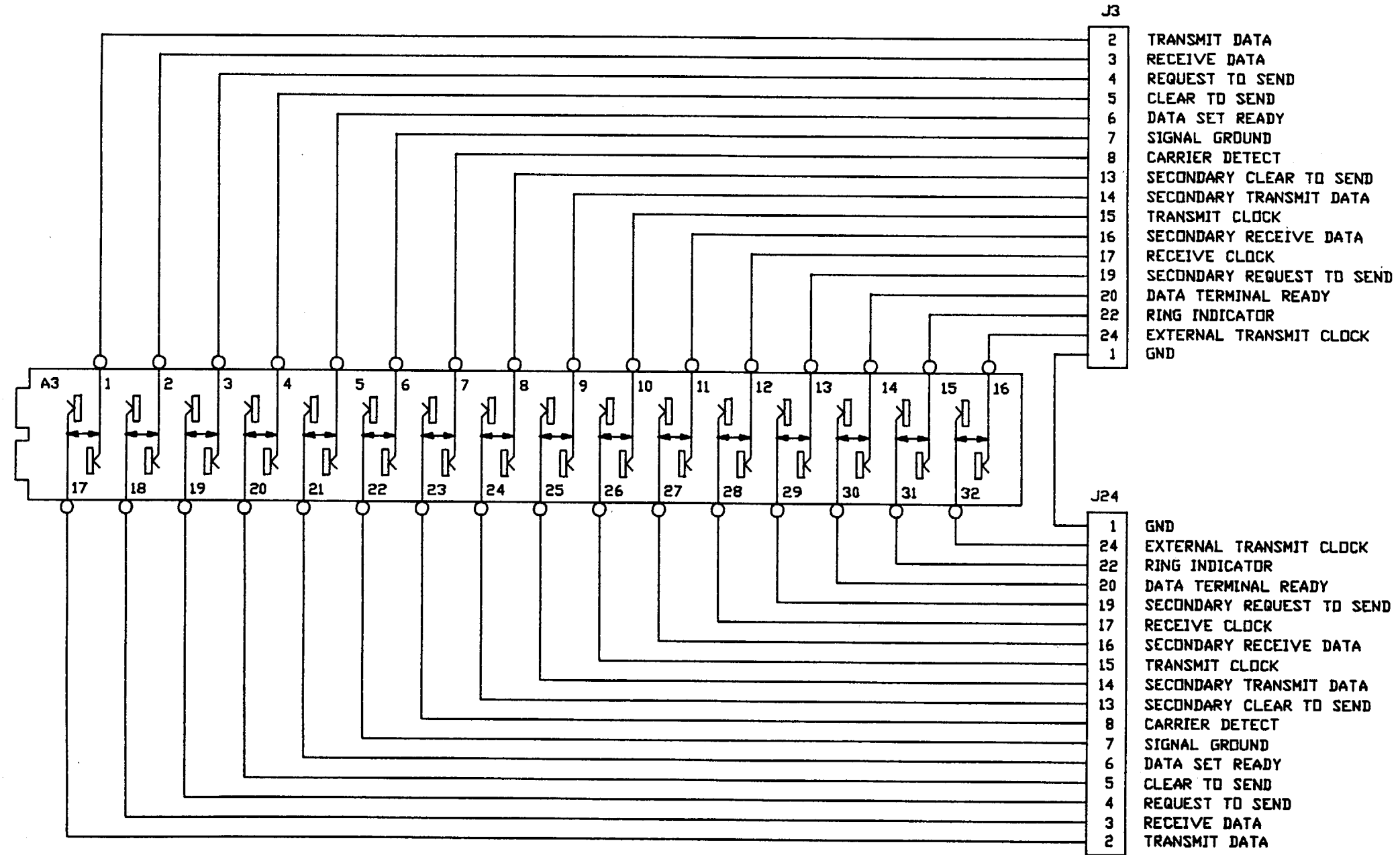

A3093161

Schematic Diagram, Patch Panel - Red (Sheet 3 of 22)

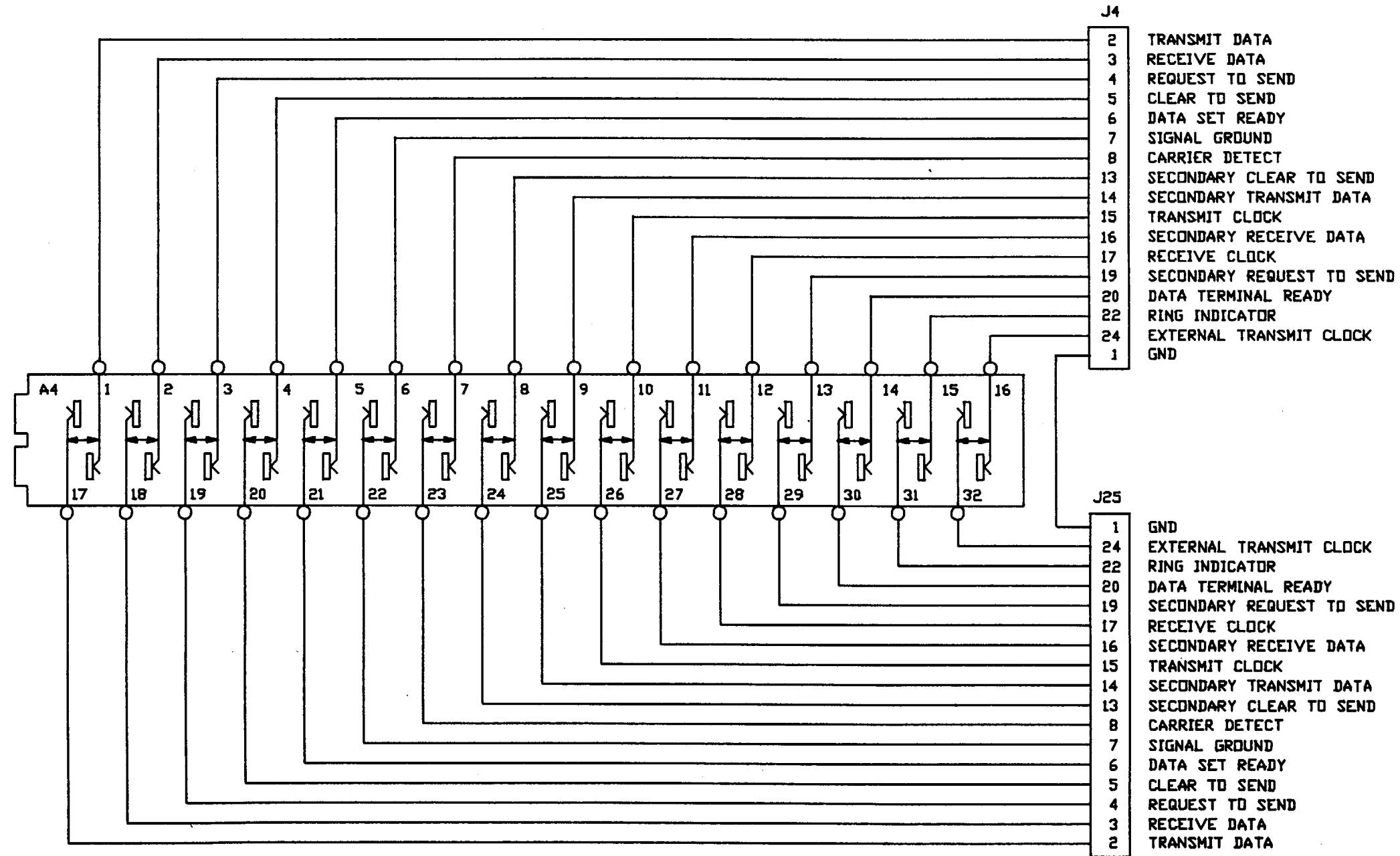

A3093161

Schematic Diagram, Patch Panel - Red (Sheet 4 of 22)

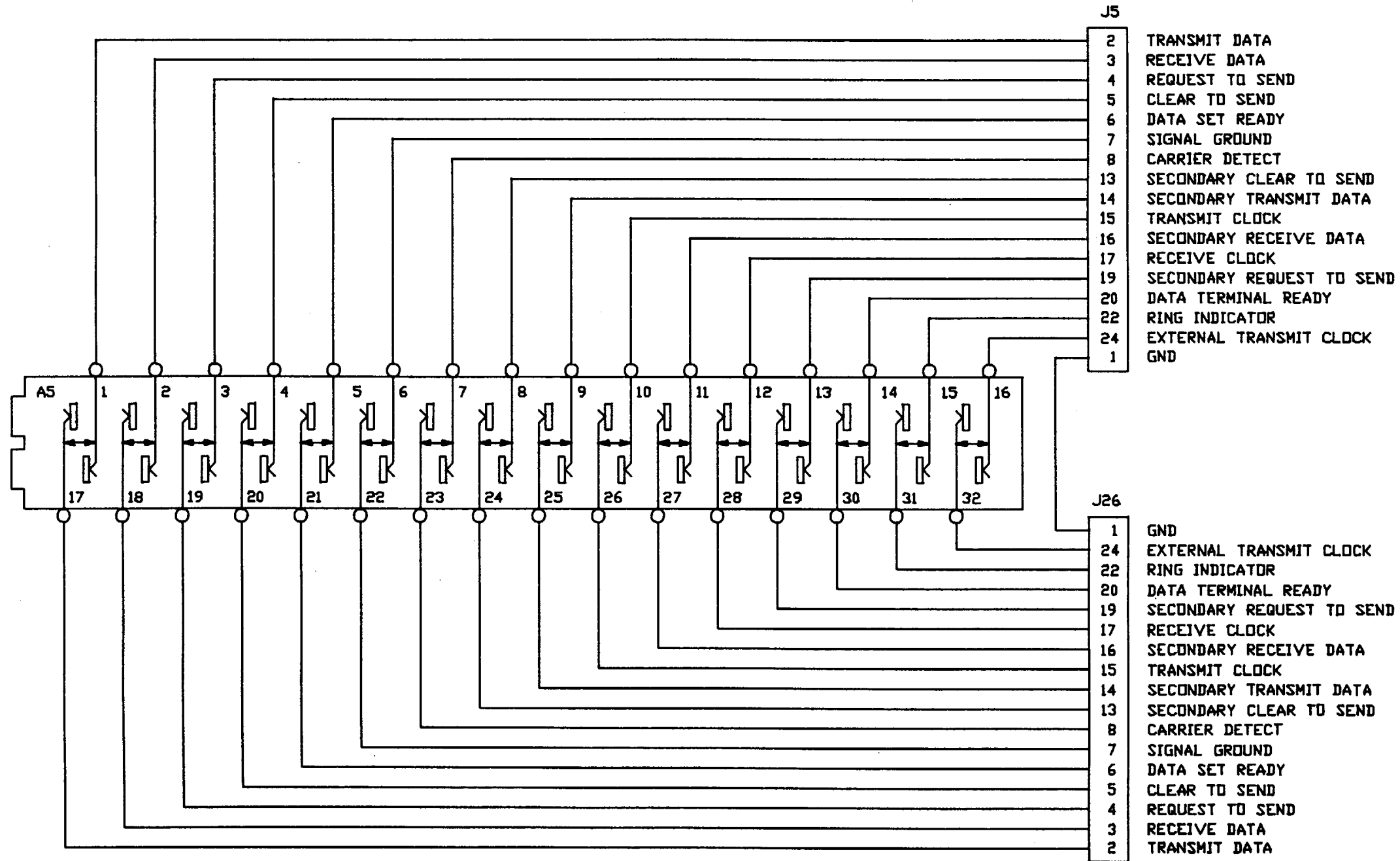

A3093161

Schematic Diagram, Patch Panel - Red (Sheet 5 of 22)

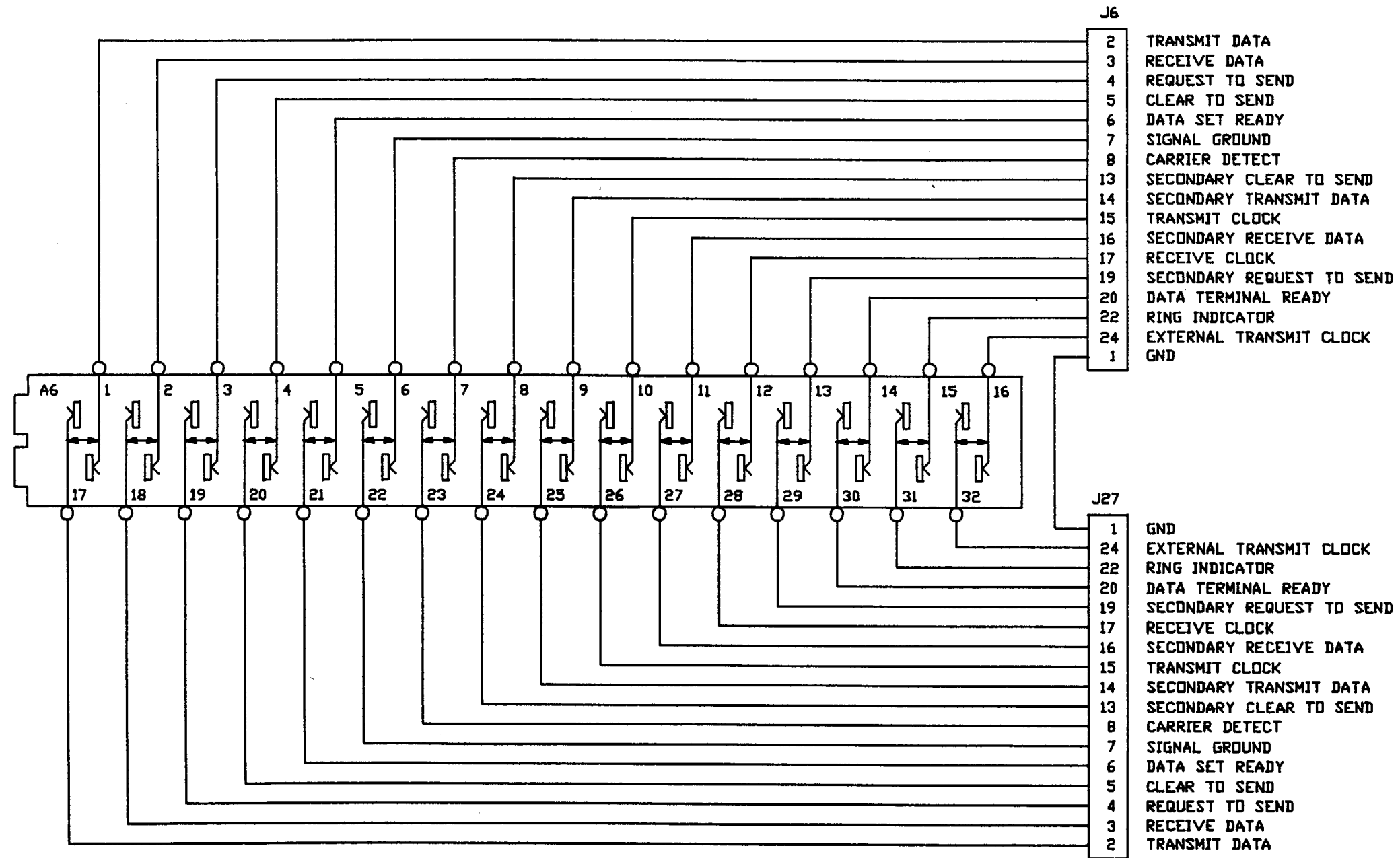

A3093161

Schematic Diagram, Patch Panel - Red (Sheet 6 of 22)

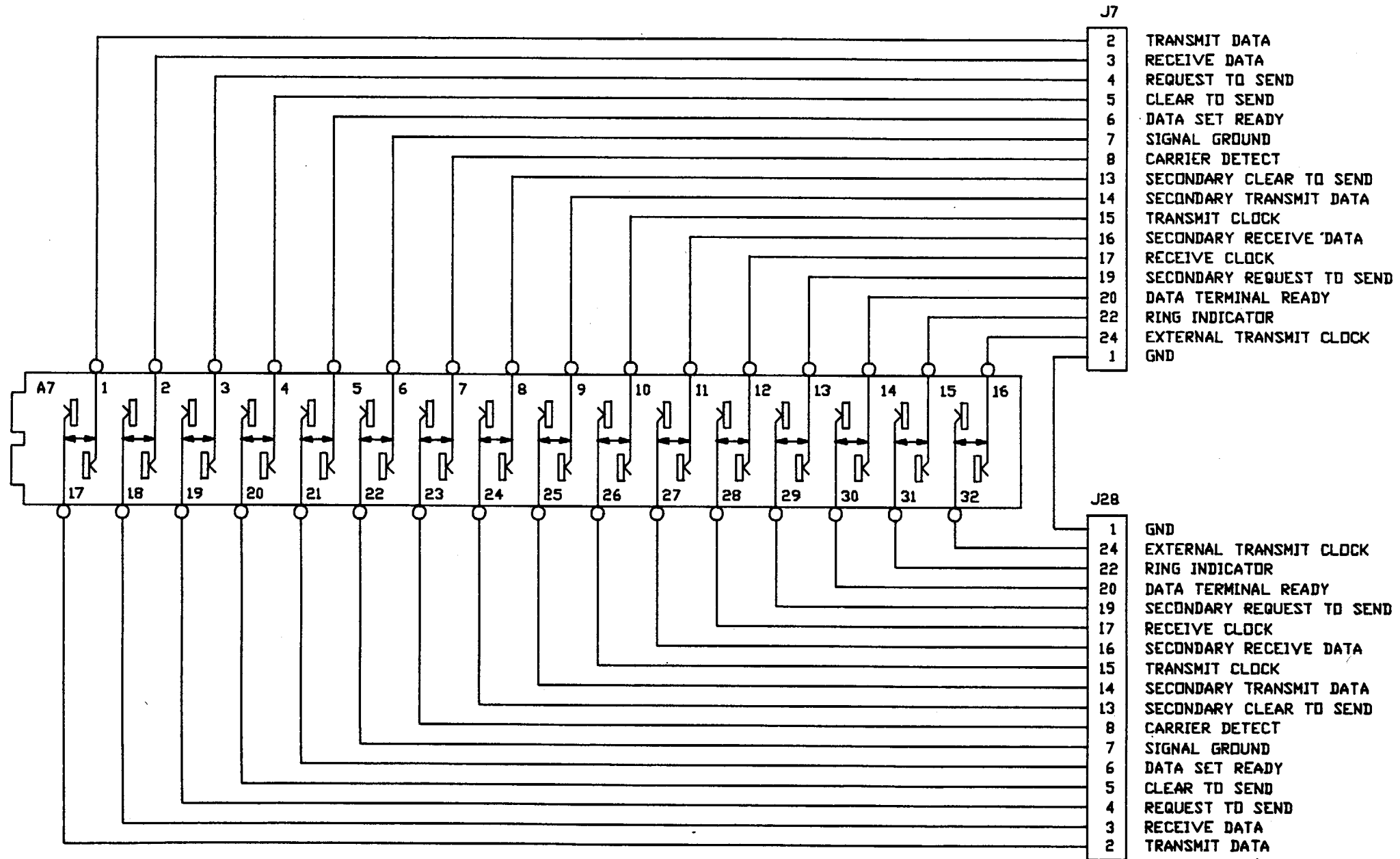

A3093161

Schematic Diagram, Patch Panel - Red (Sheet 7 of 22)

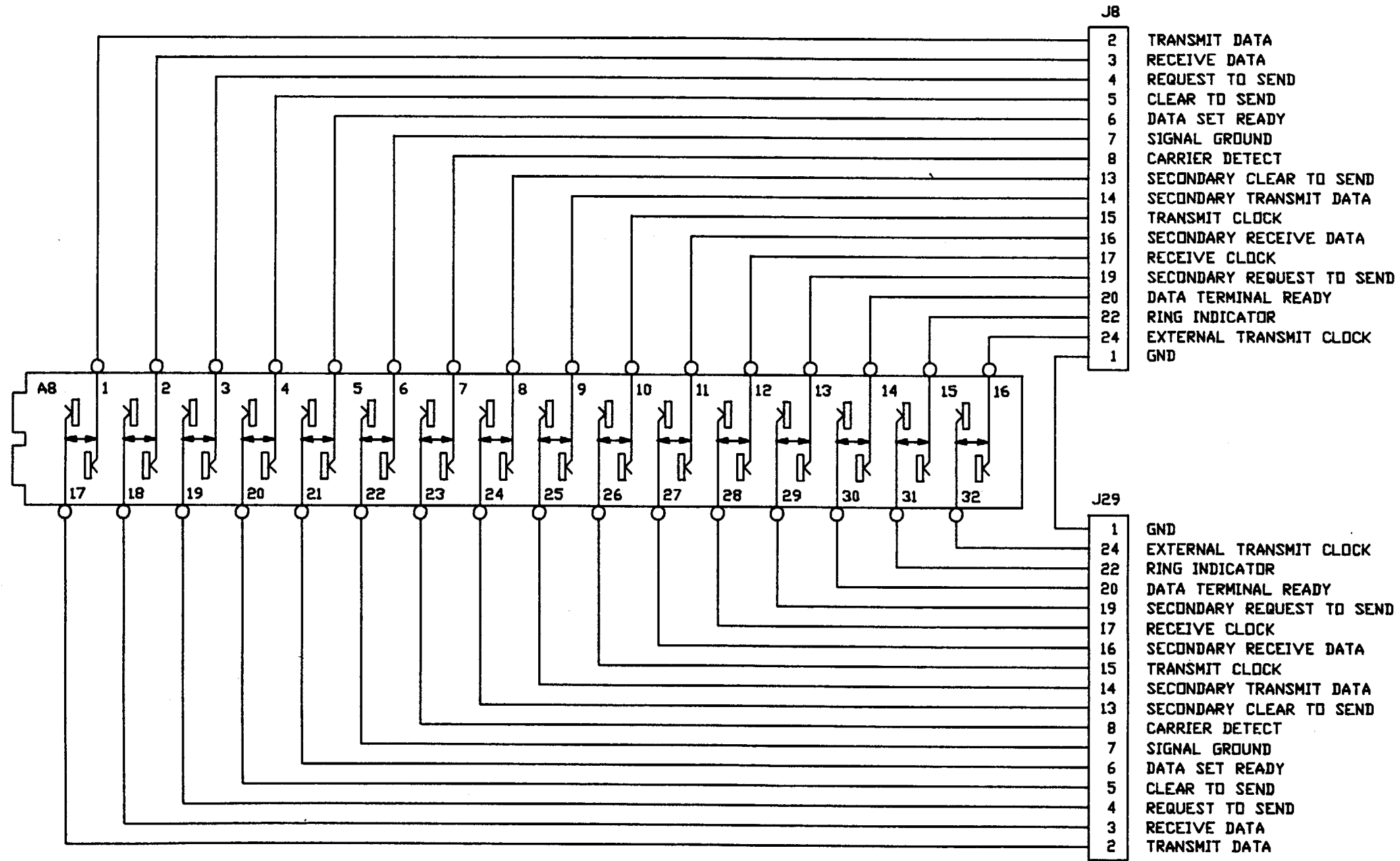

A3093161

Schematic Diagram, Patch Panel - Red (Sheet 8 of 22)

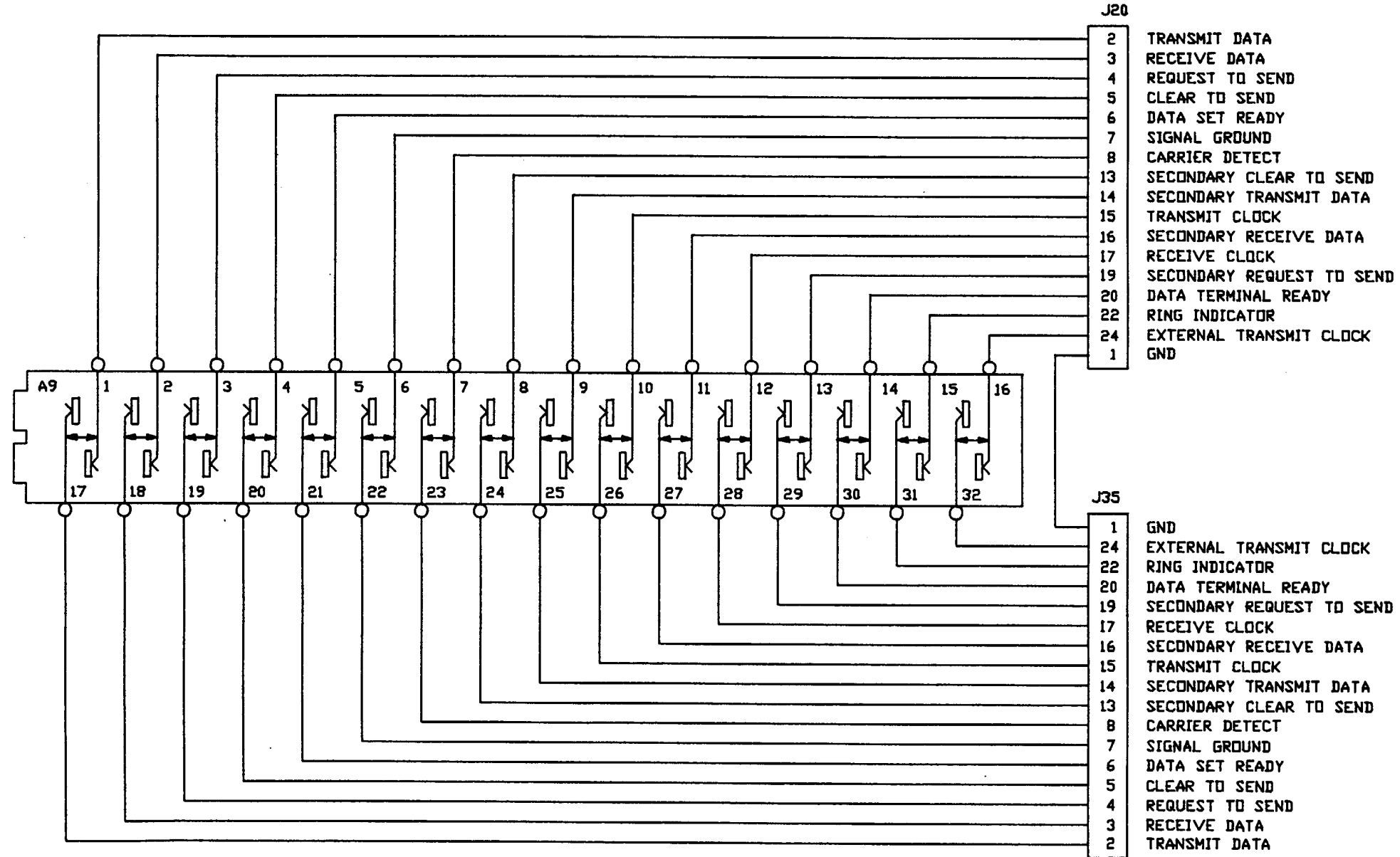

A3093161

Schematic Diagram, Patch Panel - Red (Sheet 9 of 22)

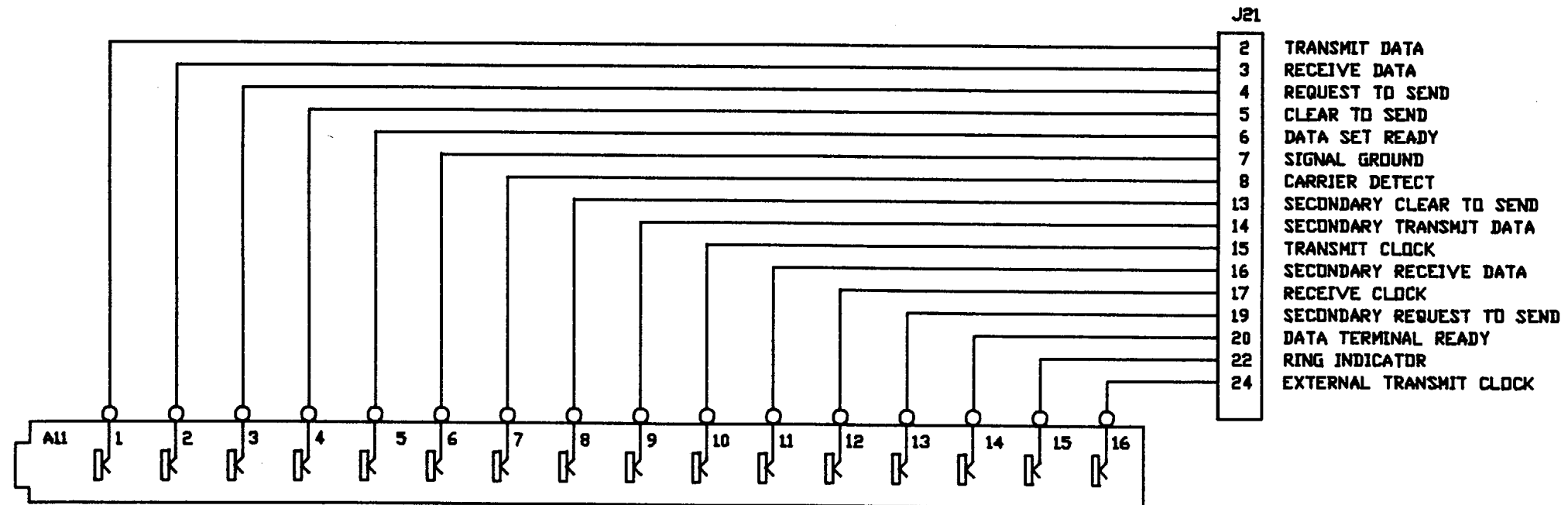
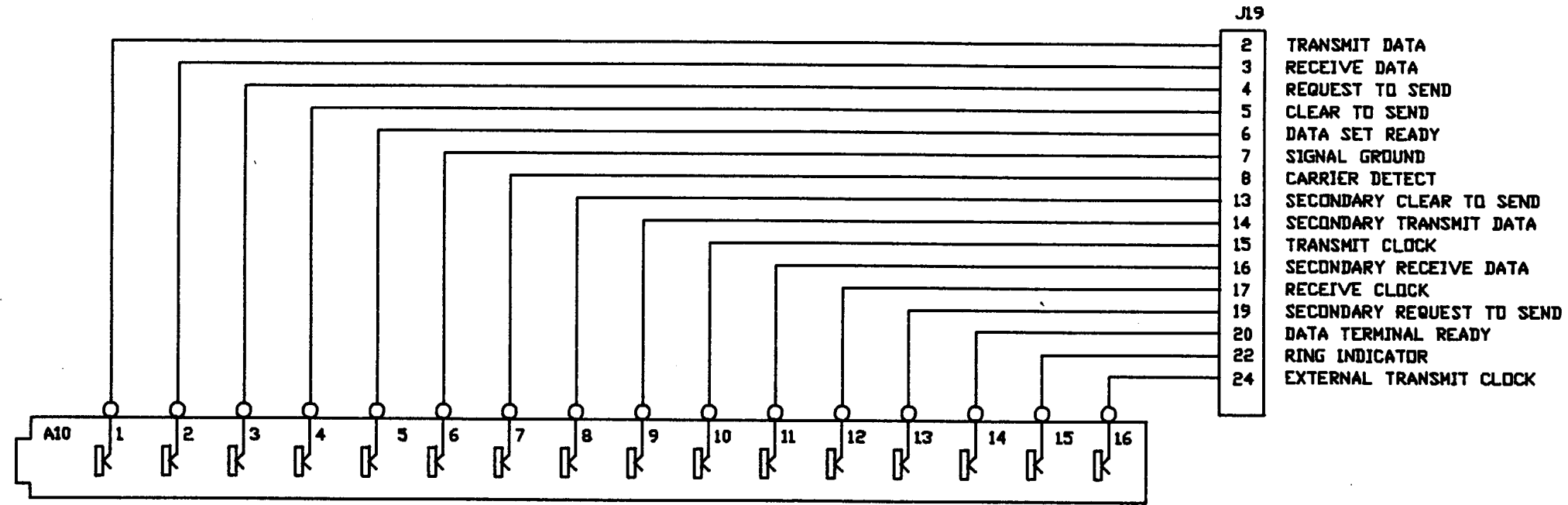

A3093161

Schematic Diagram, Patch Panel - Red (Sheet 10 of 22)

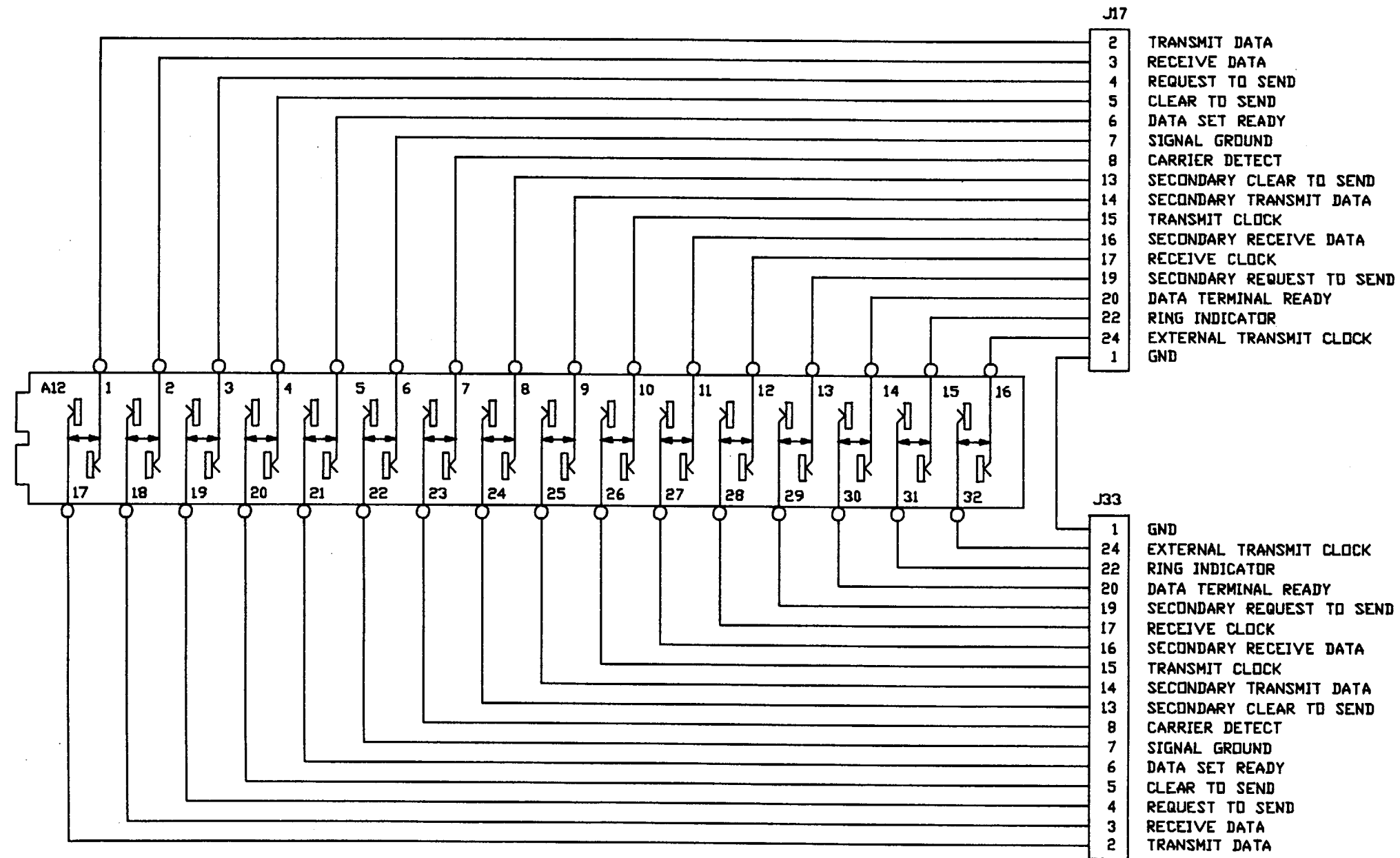

A3093161

Schematic Diagram, Patch Panel - Red (Sheet 11 of 22)

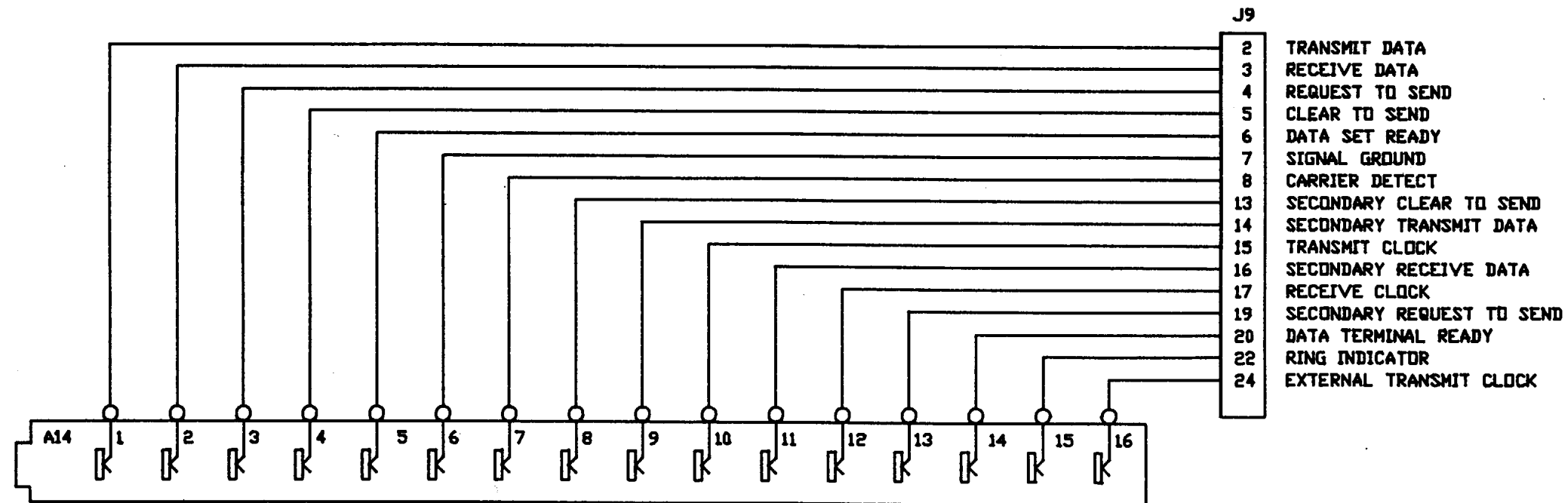
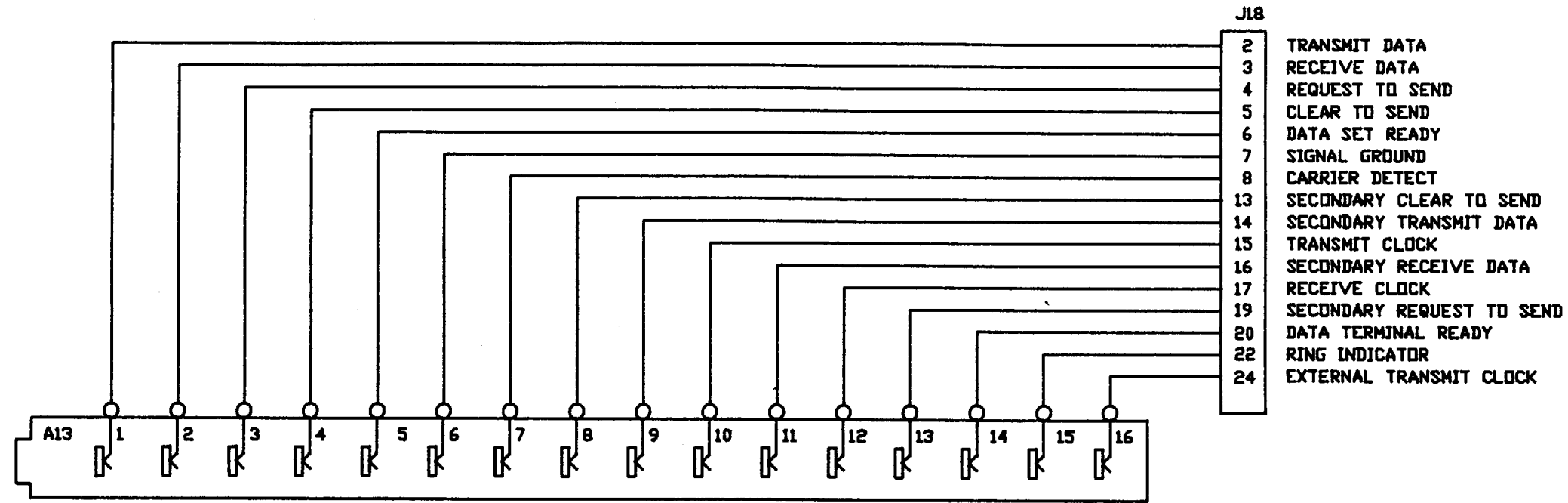

A3093161

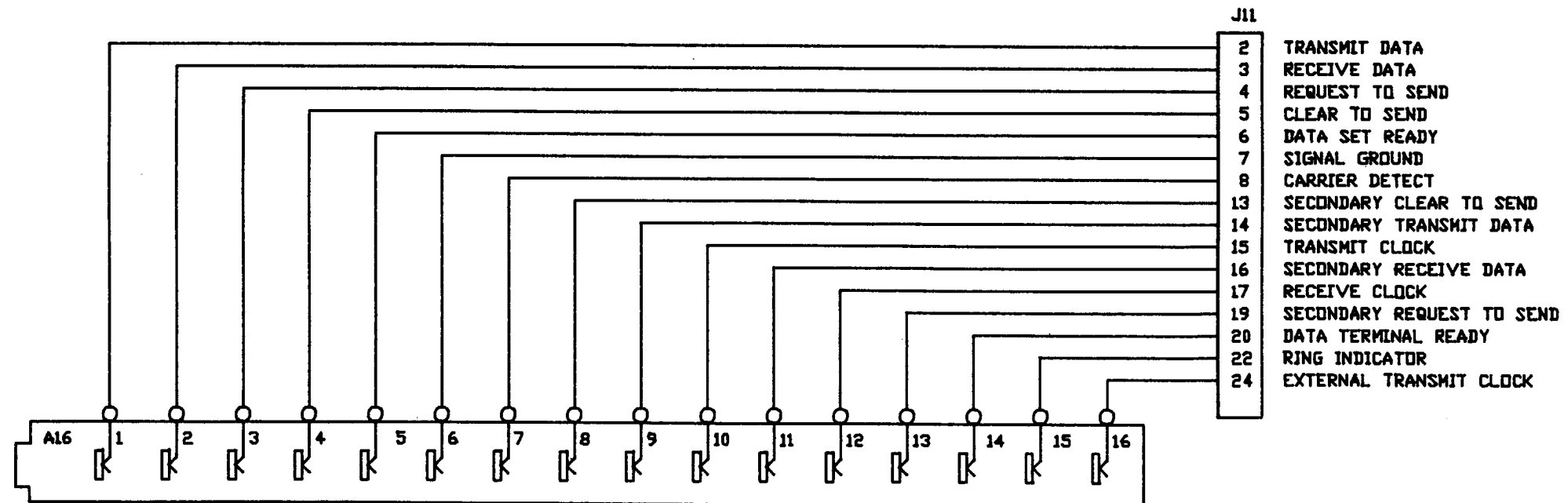
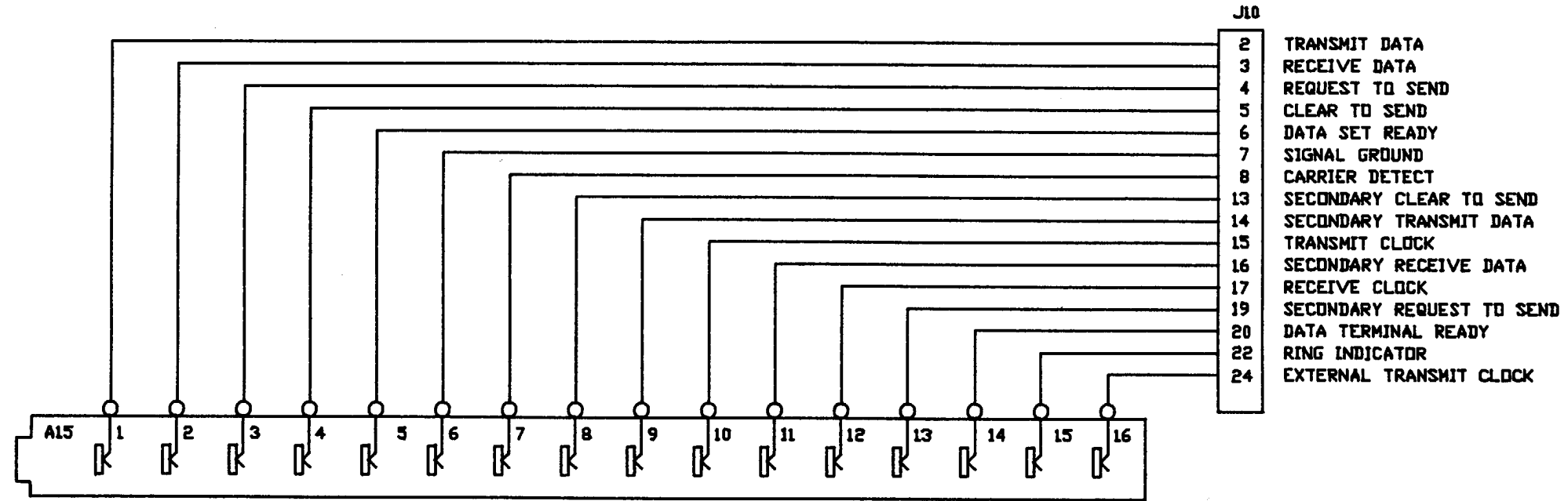

A3093161

Schematic Diagram, Patch Panel - Red (Sheet 13 of 22)

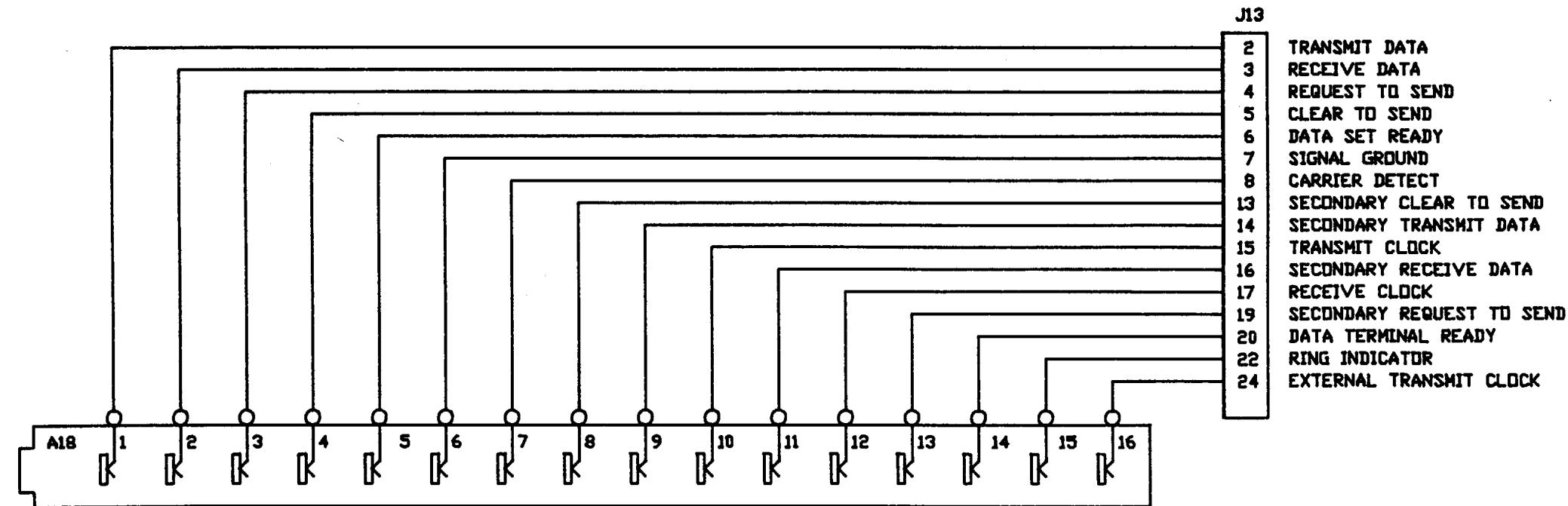
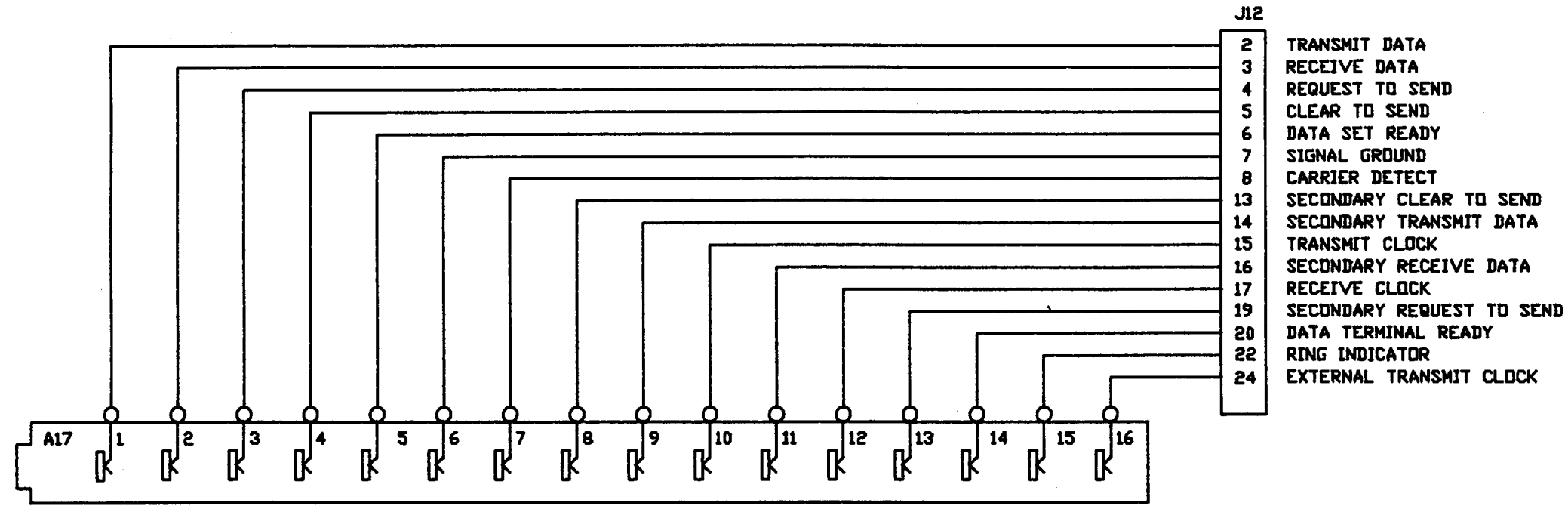

A3093161

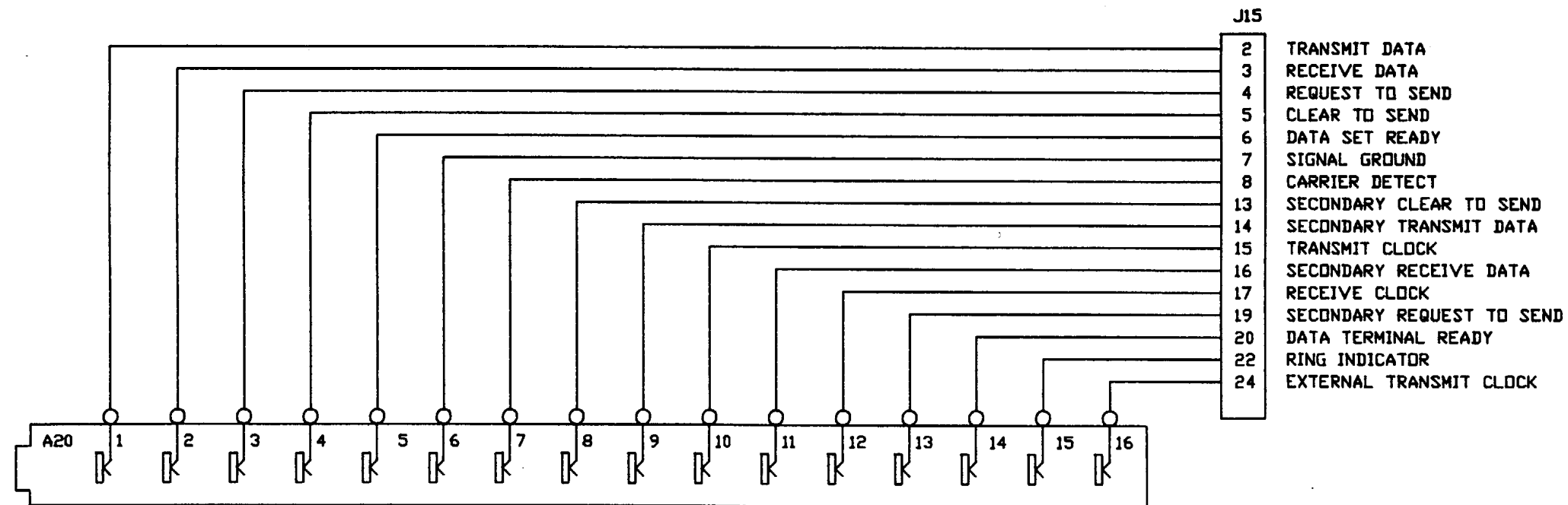
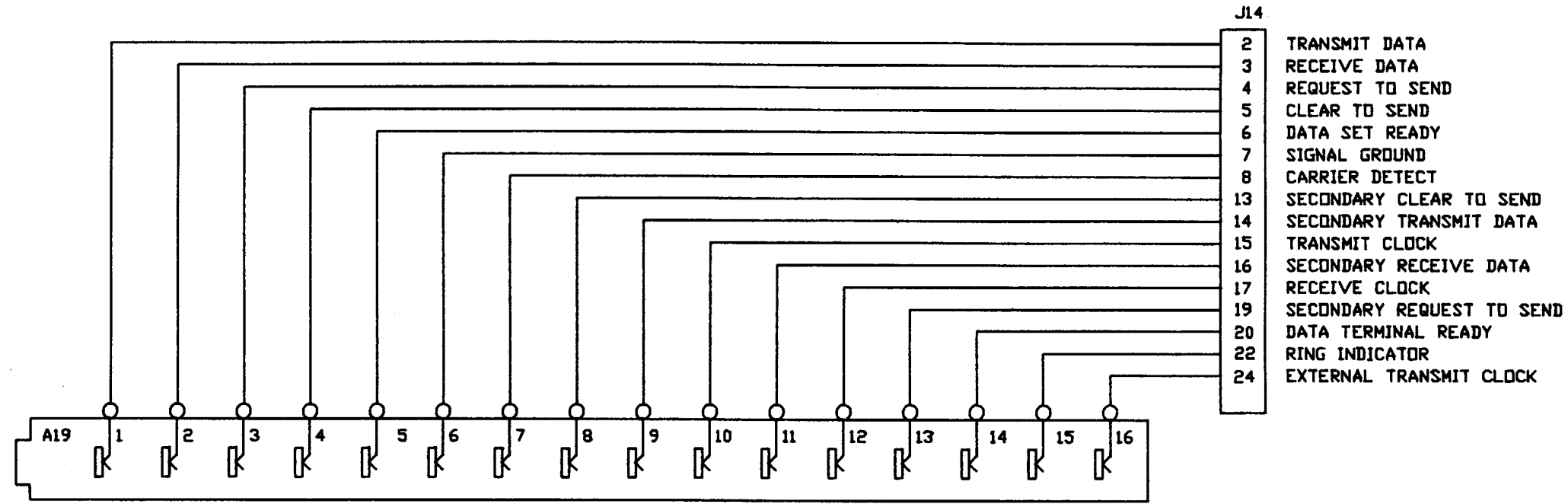

A3093161

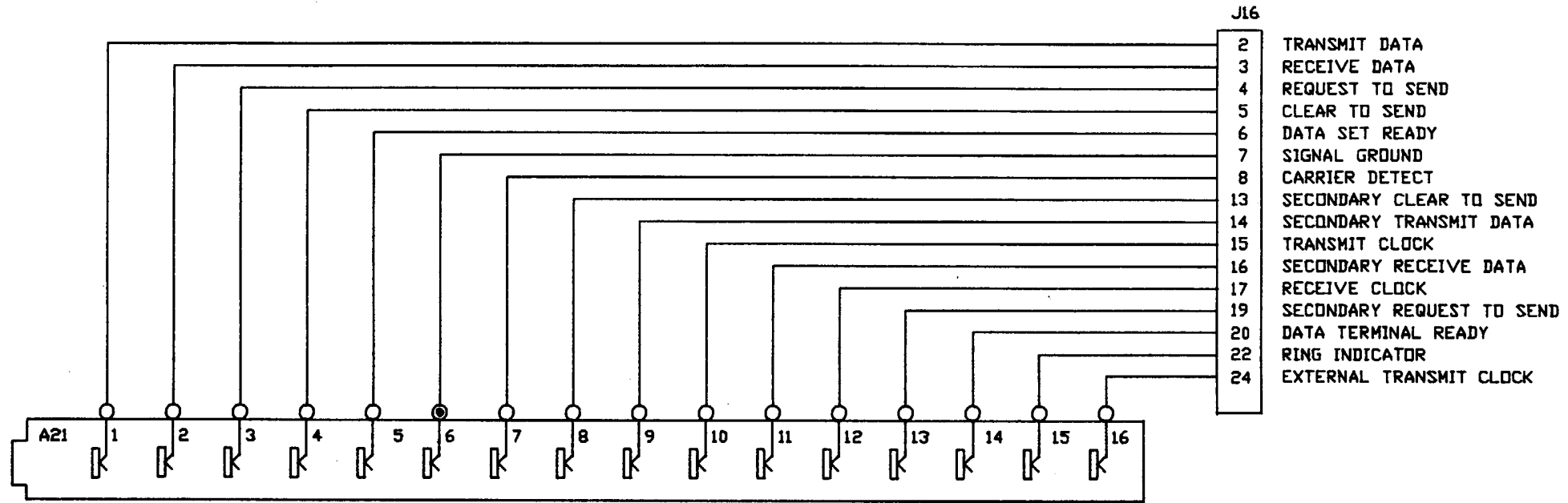

A3093161

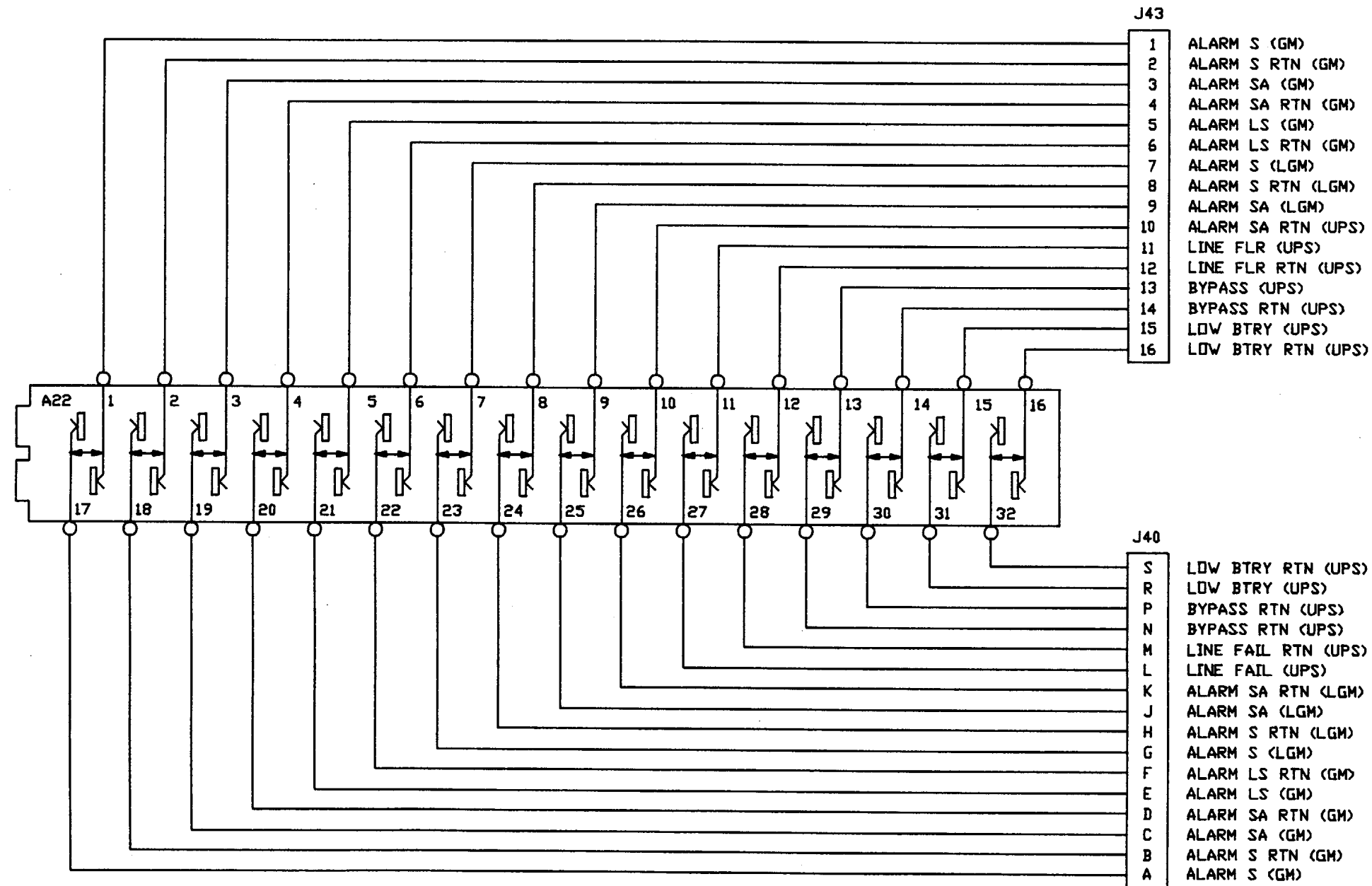

A3093161

Schematic Diagram, Patch Panel - Red (Sheet 17 of 22)

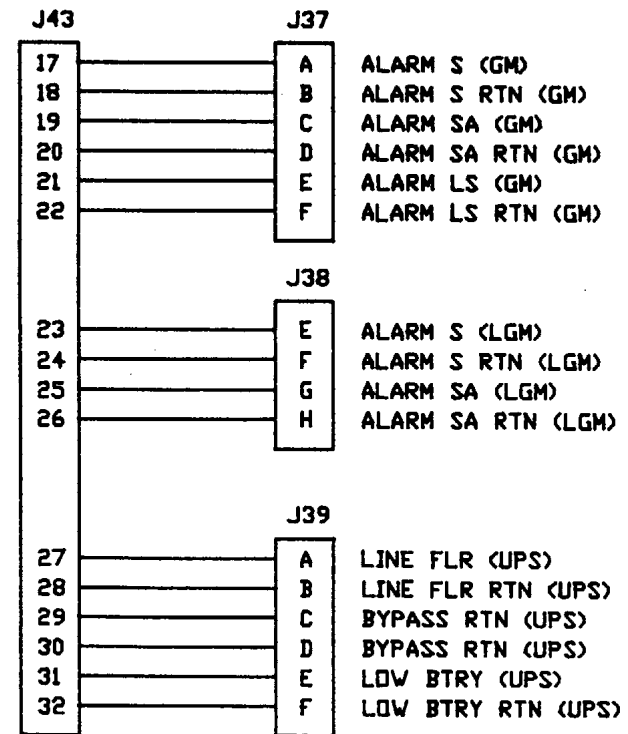
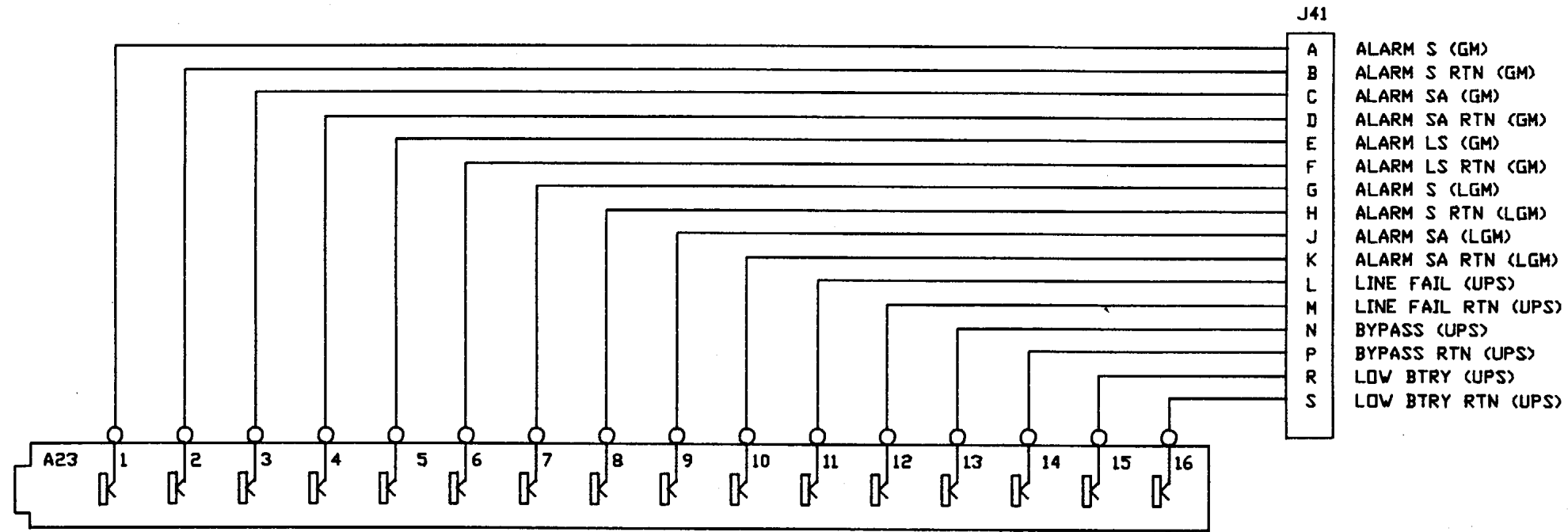

A3093161

Schematic Diagram, Patch Panel - Red (Sheet 18 of 22)

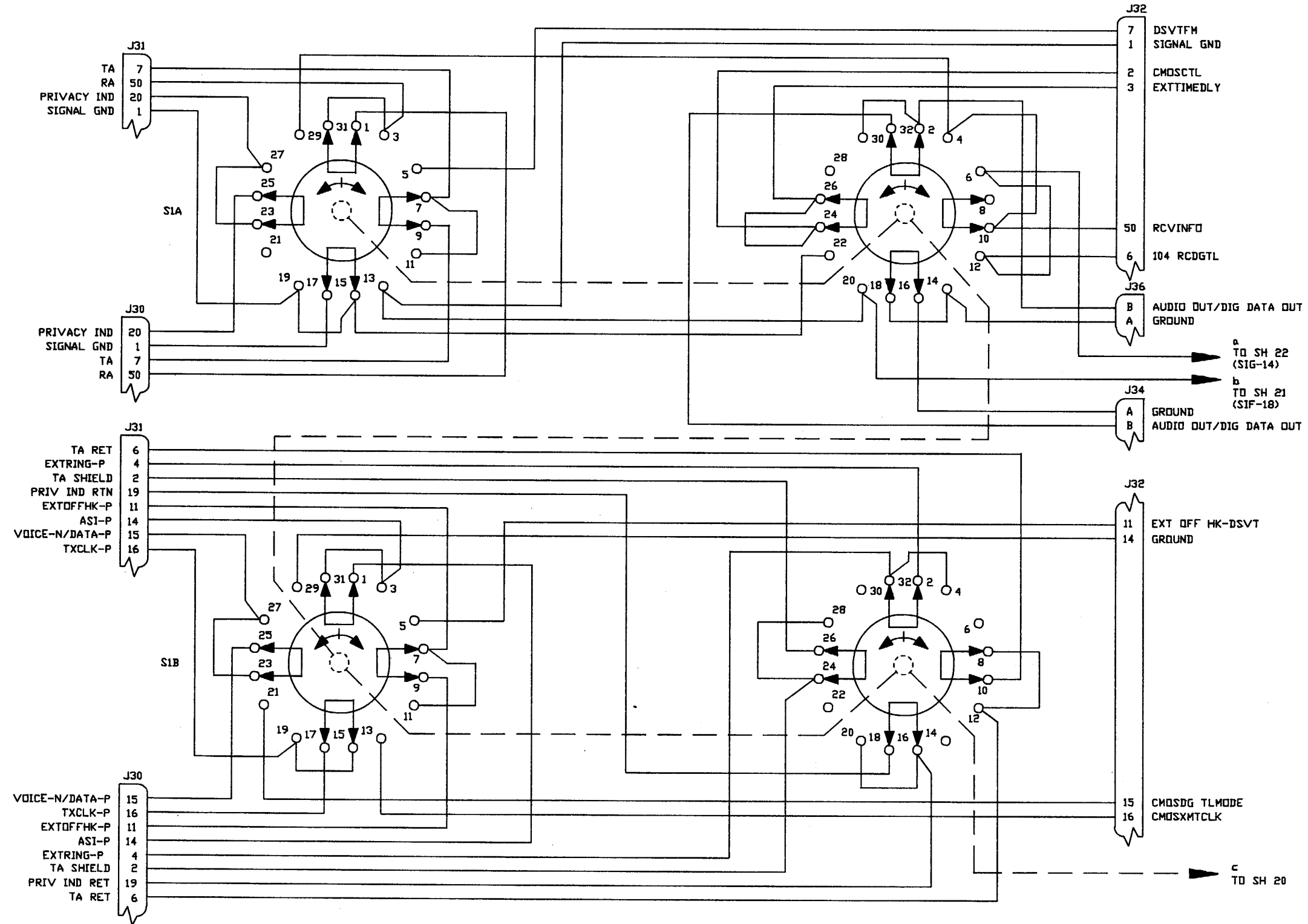

A3093161

Schematic Diagram, Patch Panel - Red (Sheet 19 of 22)

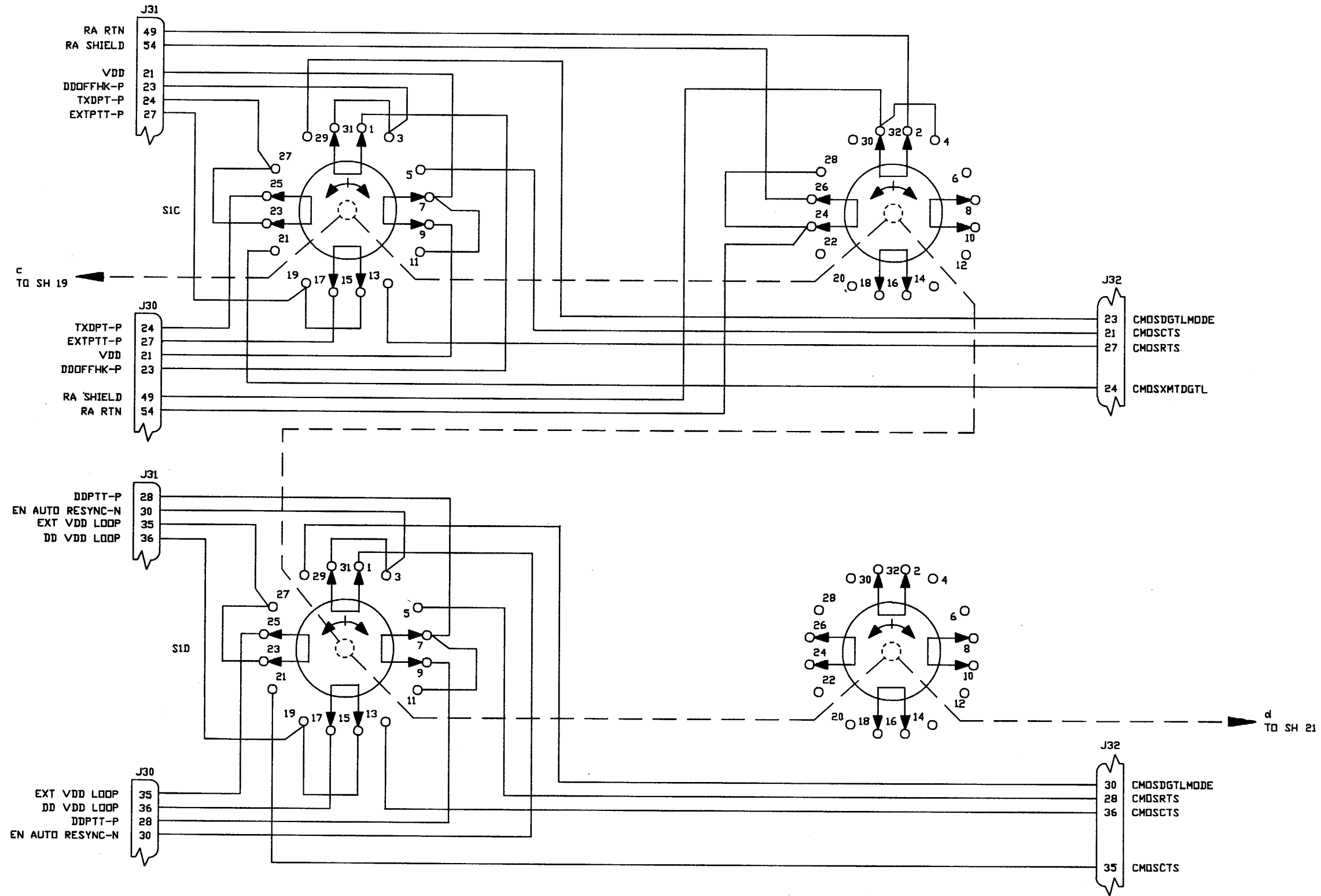

A3093161

Schematic Diagram, Patch Panel - Red (Sheet 20 of 22)

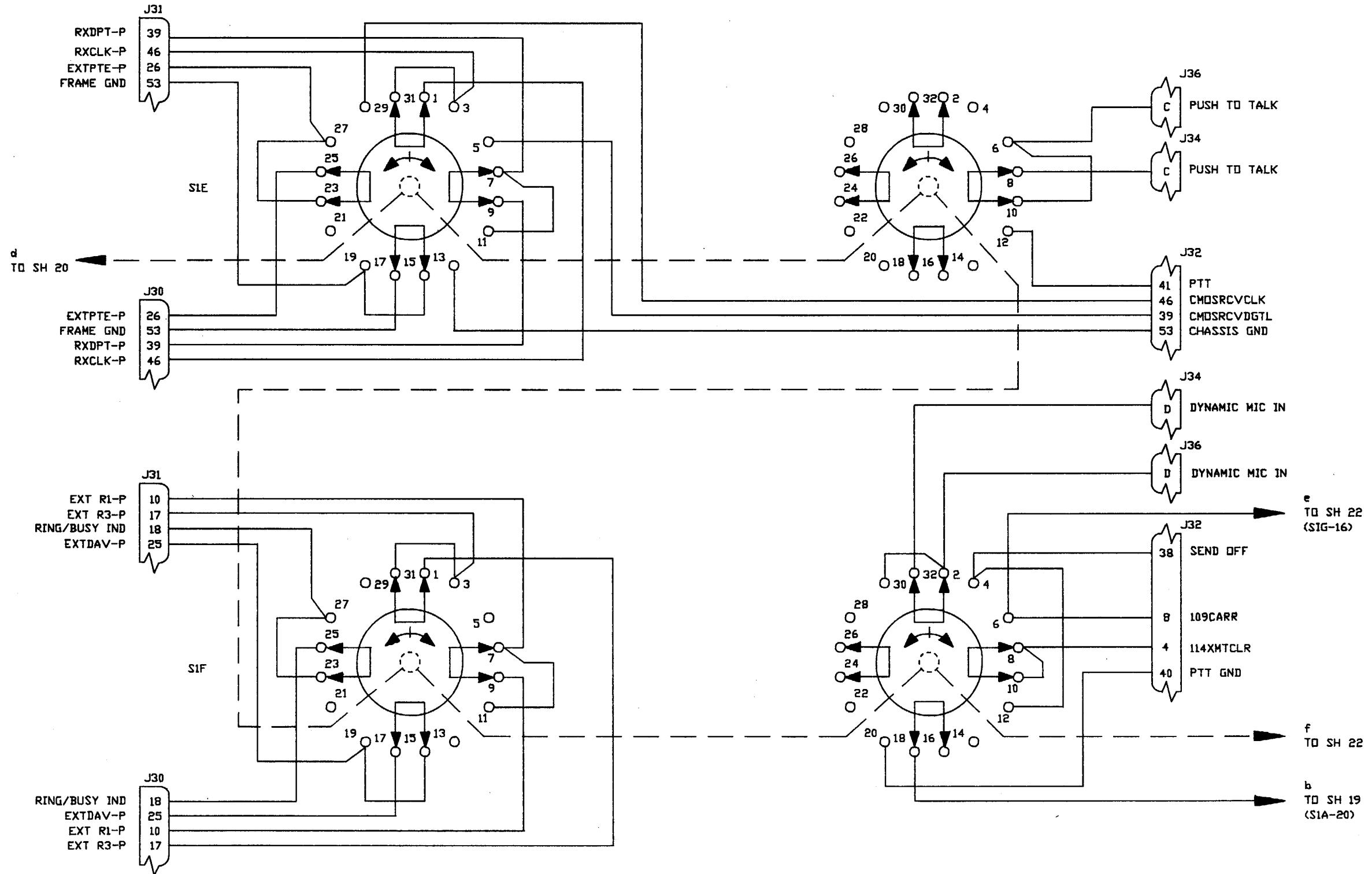

Schematic Diagram, Patch Panel - Red (Sheet 21 of 22)

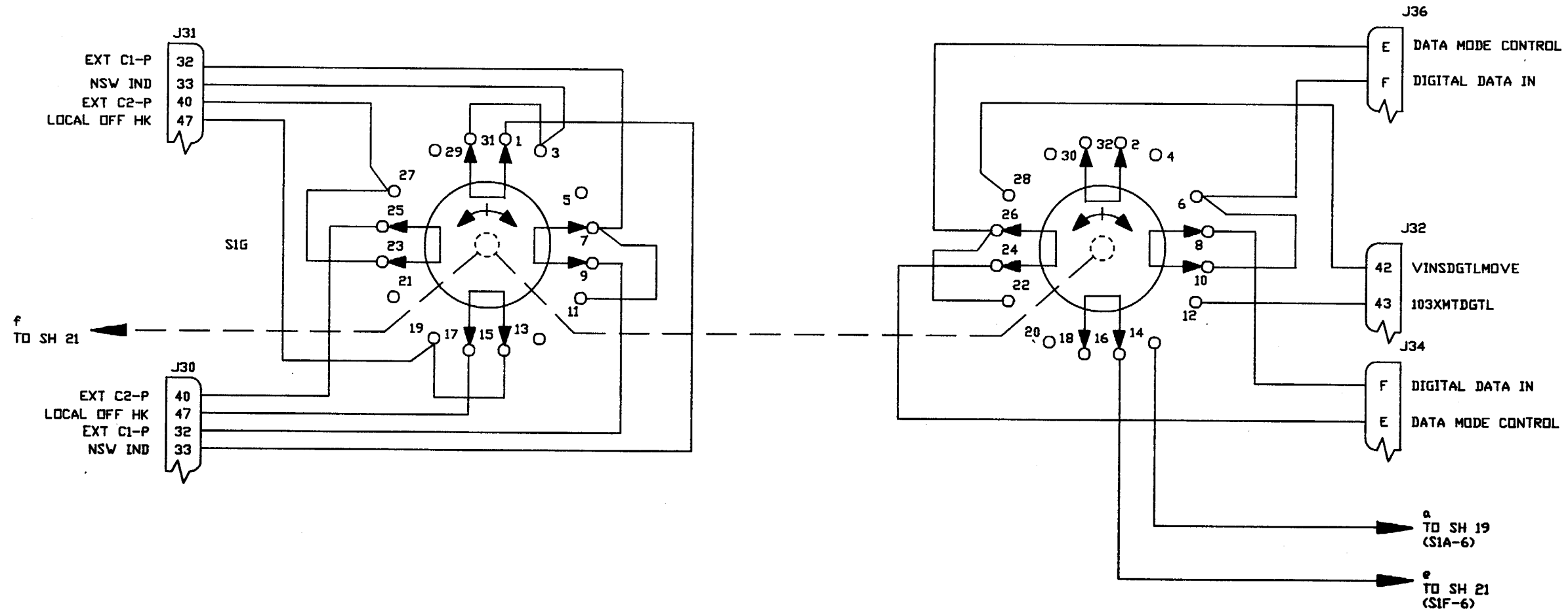

Schematic Diagram, Patch Panel - Red (Sheet 22 of 22)

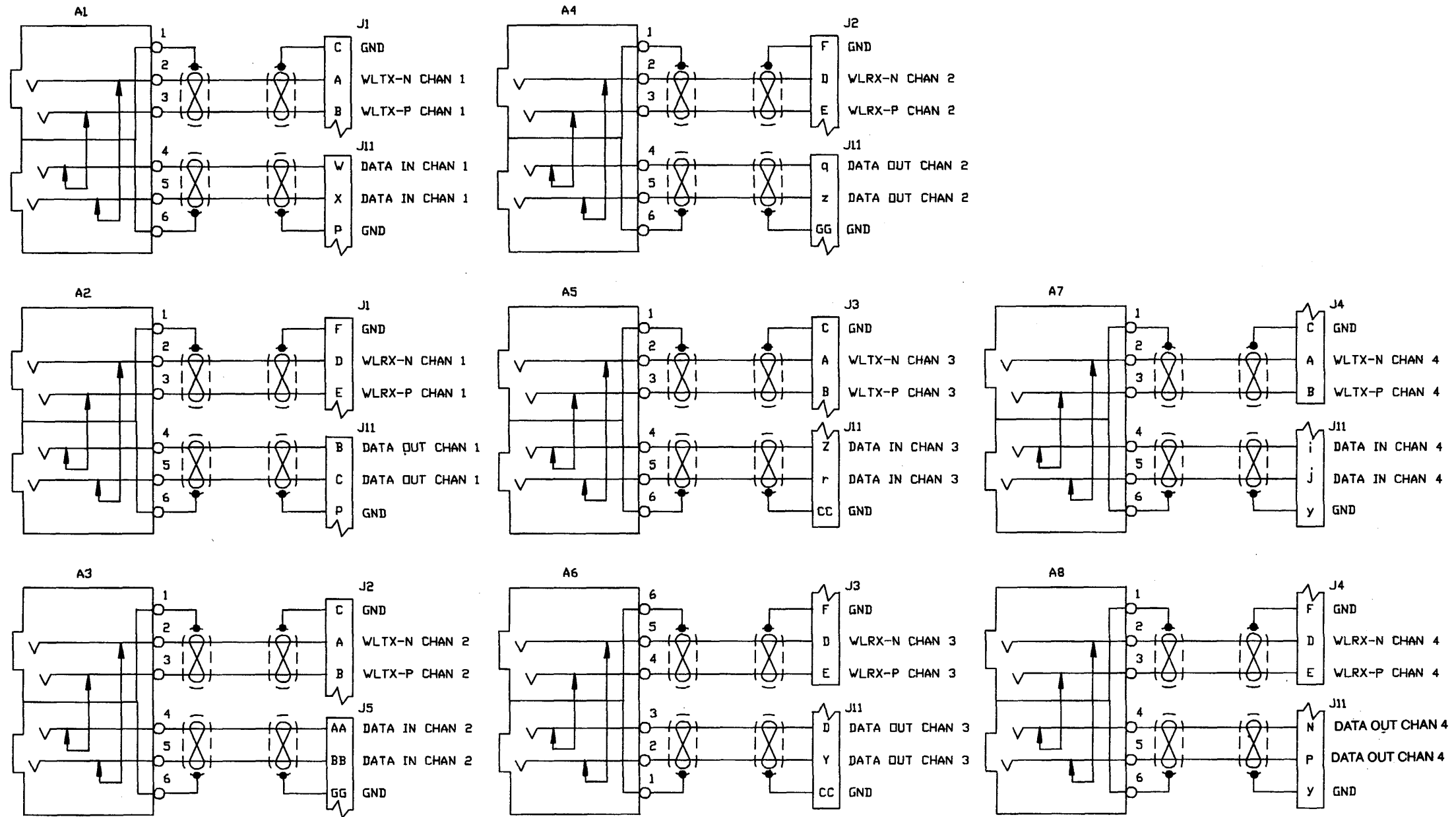

NOTES :

1. PARTIAL REFERENCE DESIGNATIONS ARE SHOWN. FOR COMPLETE REFERENCE DESIGNATION, PREFIX WITH UNIT NUMBER AND SUBASSEMBLY DESIGNATION.
2. ALL UNUSED POSITIONS IN CONNECTORS J1-J29 WILL BE FILLED WITH CONTACTS.
3. DAISY CHAINS BETWEEN COMMON CONNECTOR CONTACTS OMITTED FOR CLARITY.

A3093171

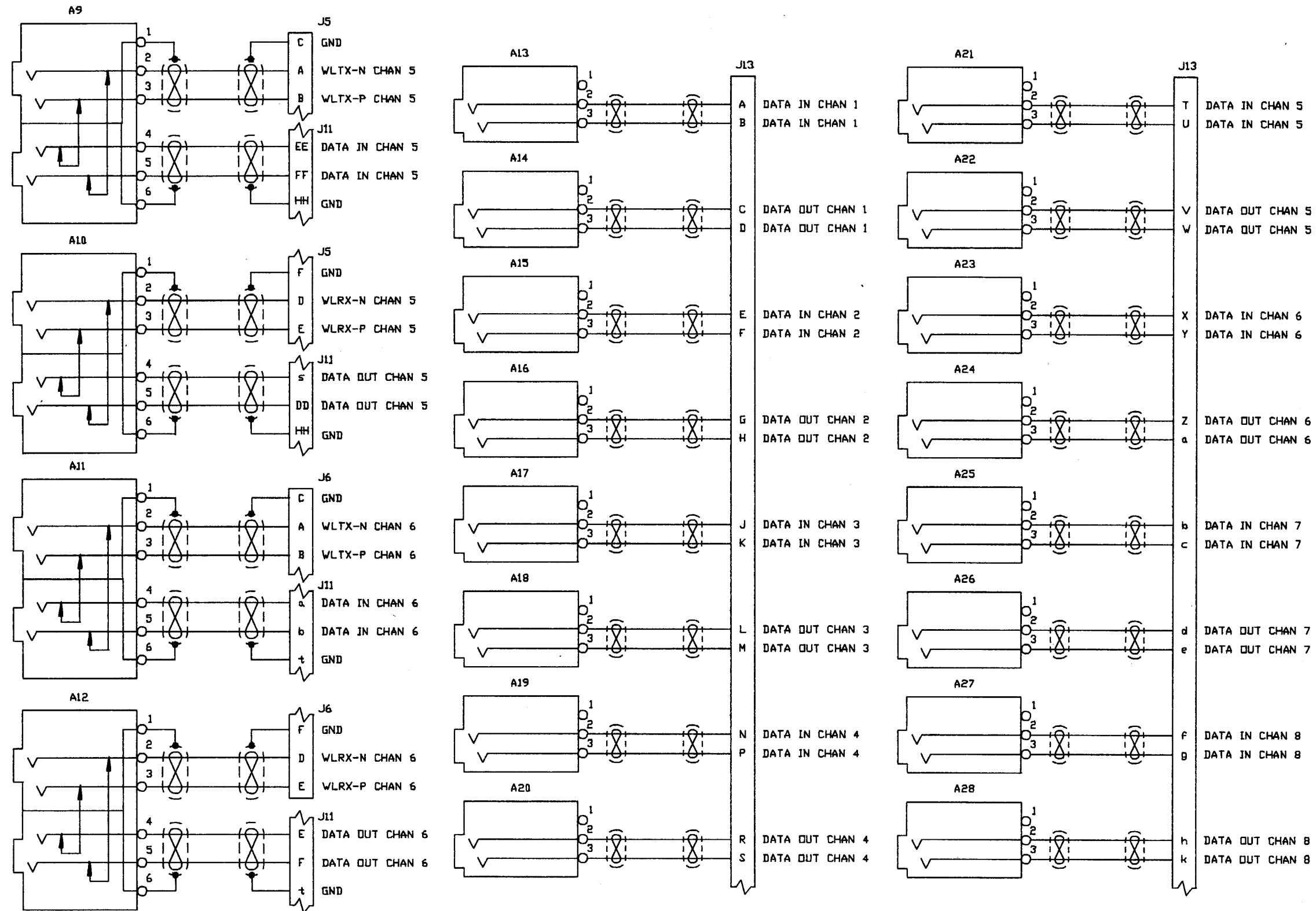

Schematic Diagram, Black Patch Panel - AN/TYQ30
(Sheet 2 of 6)

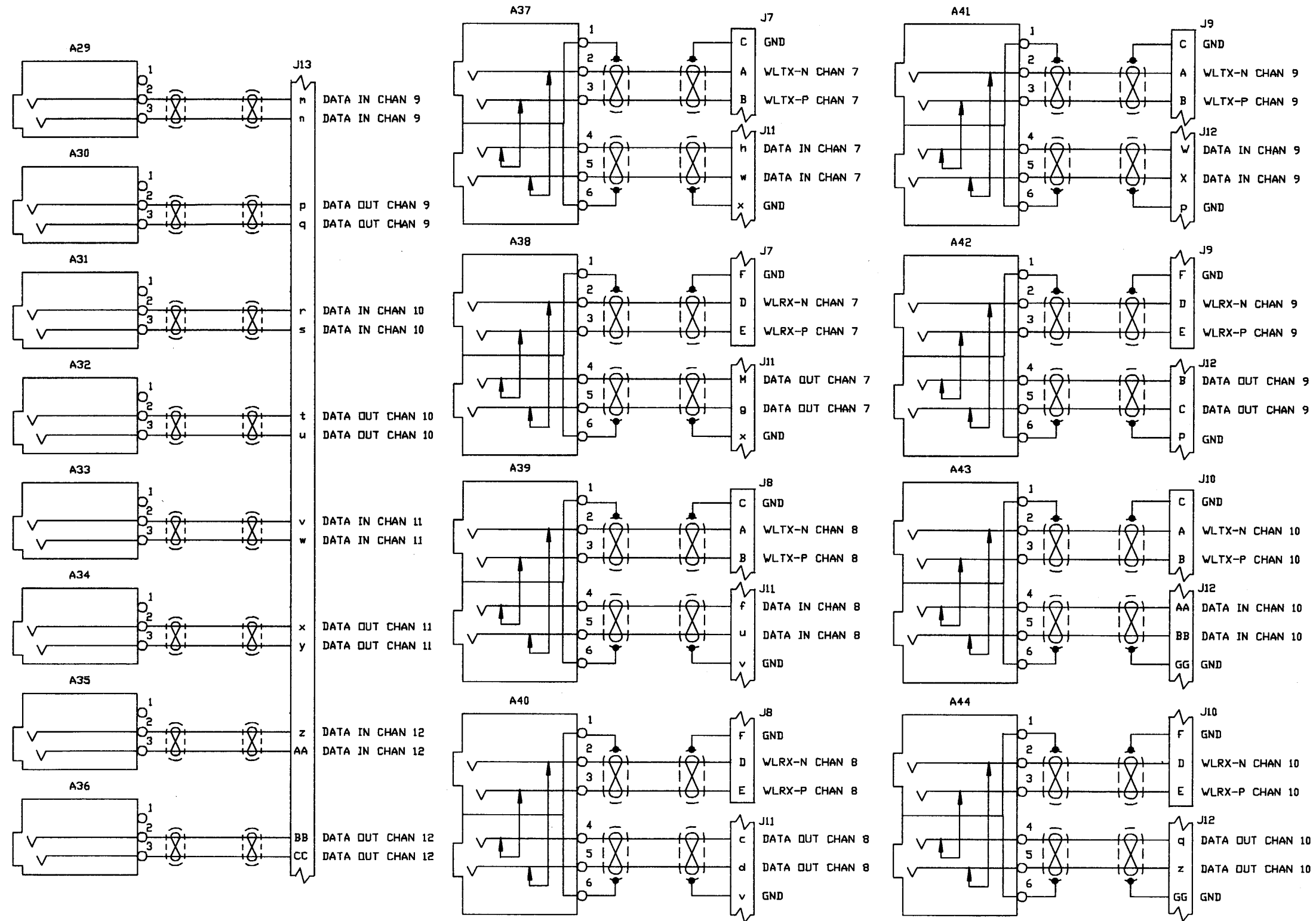

Schematic Diagram, Black Patch Panel - AN/TYQ-30
(Sheet 3 of 6)

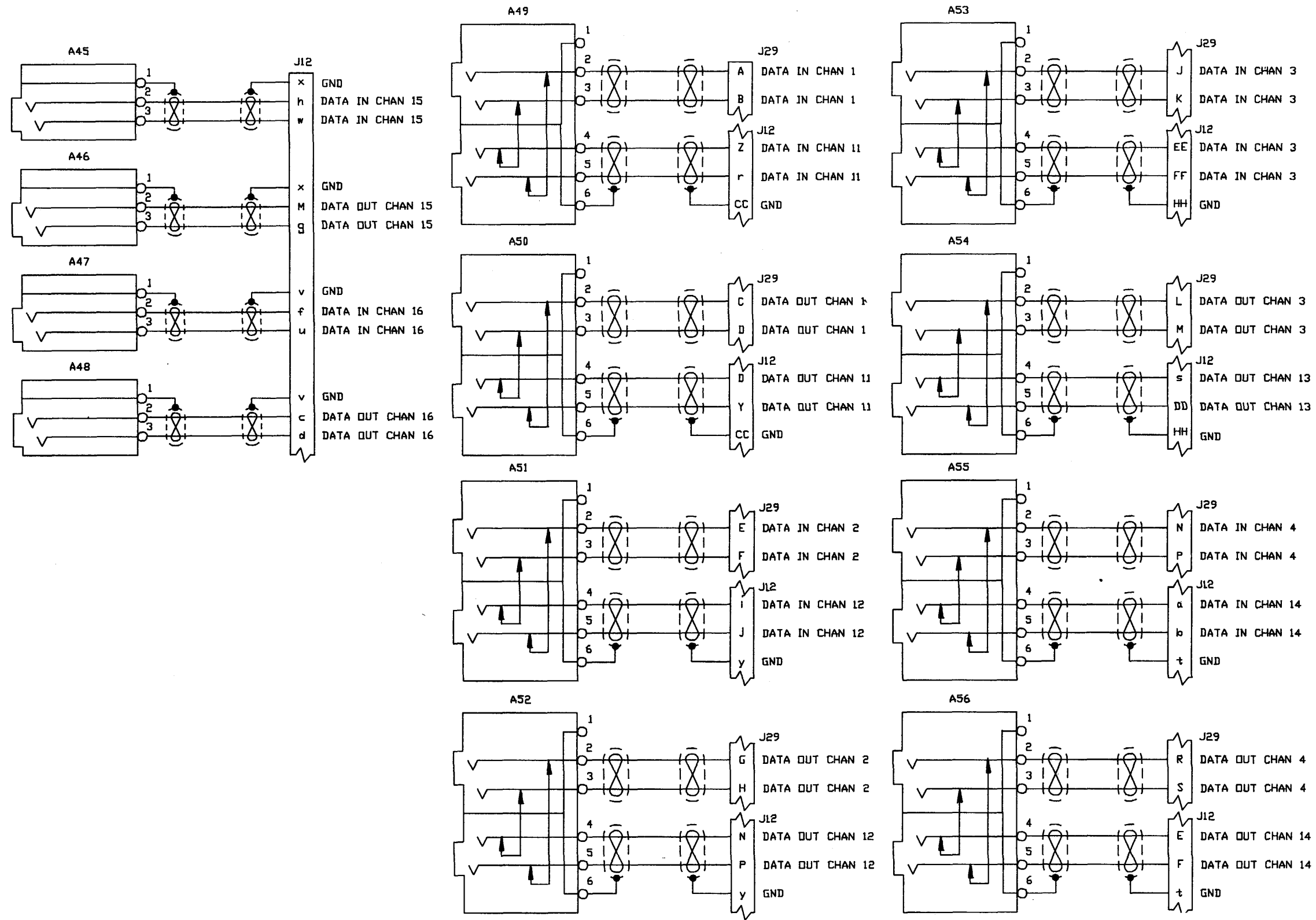

Schematic Diagram, Black Patch Panel - AN/TYQ-30
(Sheet 4 of 6)

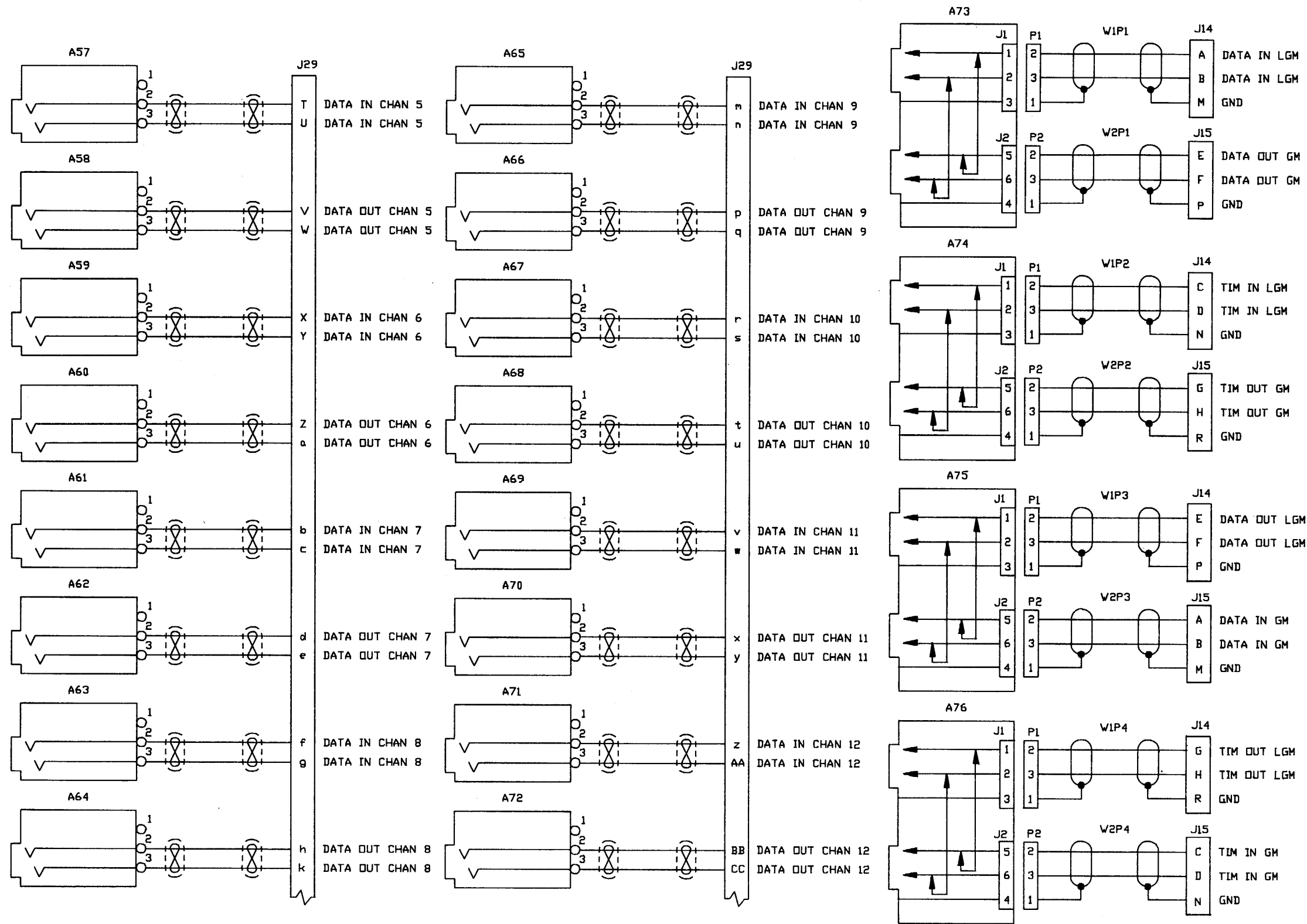

A3093171

Schematic Diagram, Black Patch Panel - AN/TYQ30
(Sheet 5 of 6)

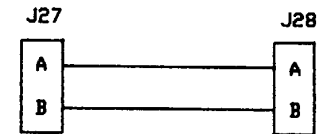
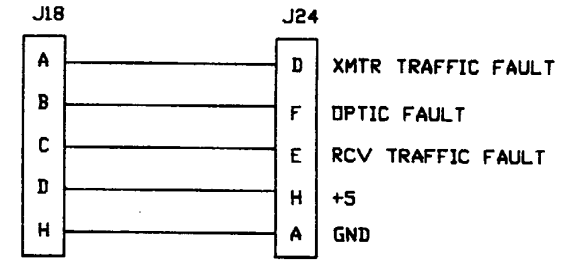
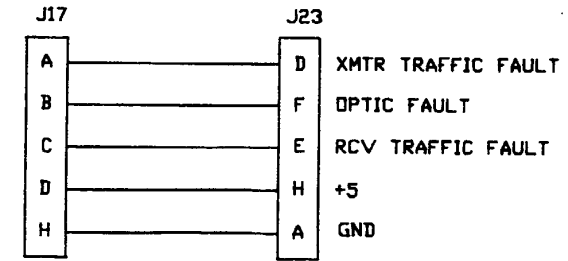
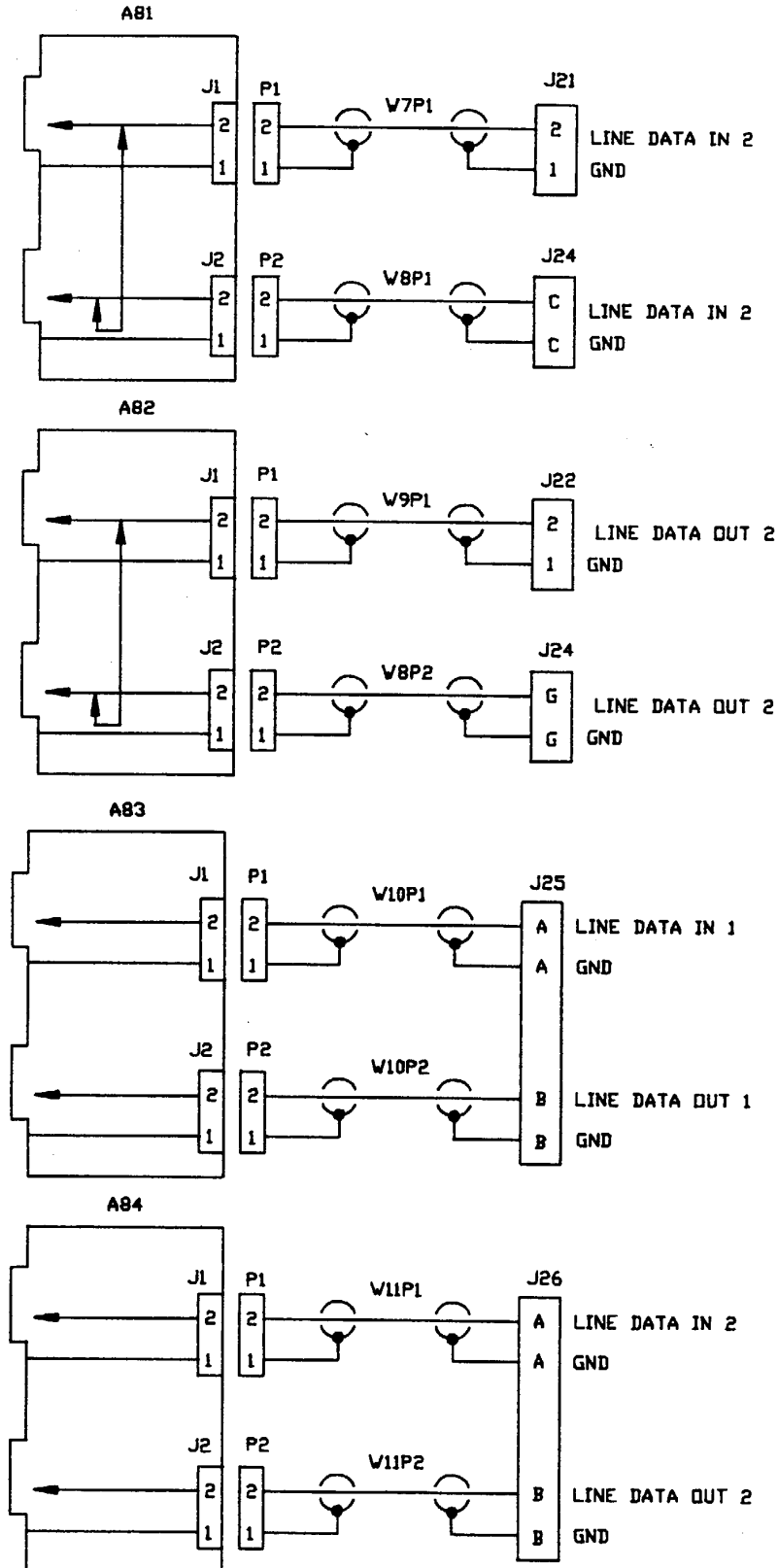
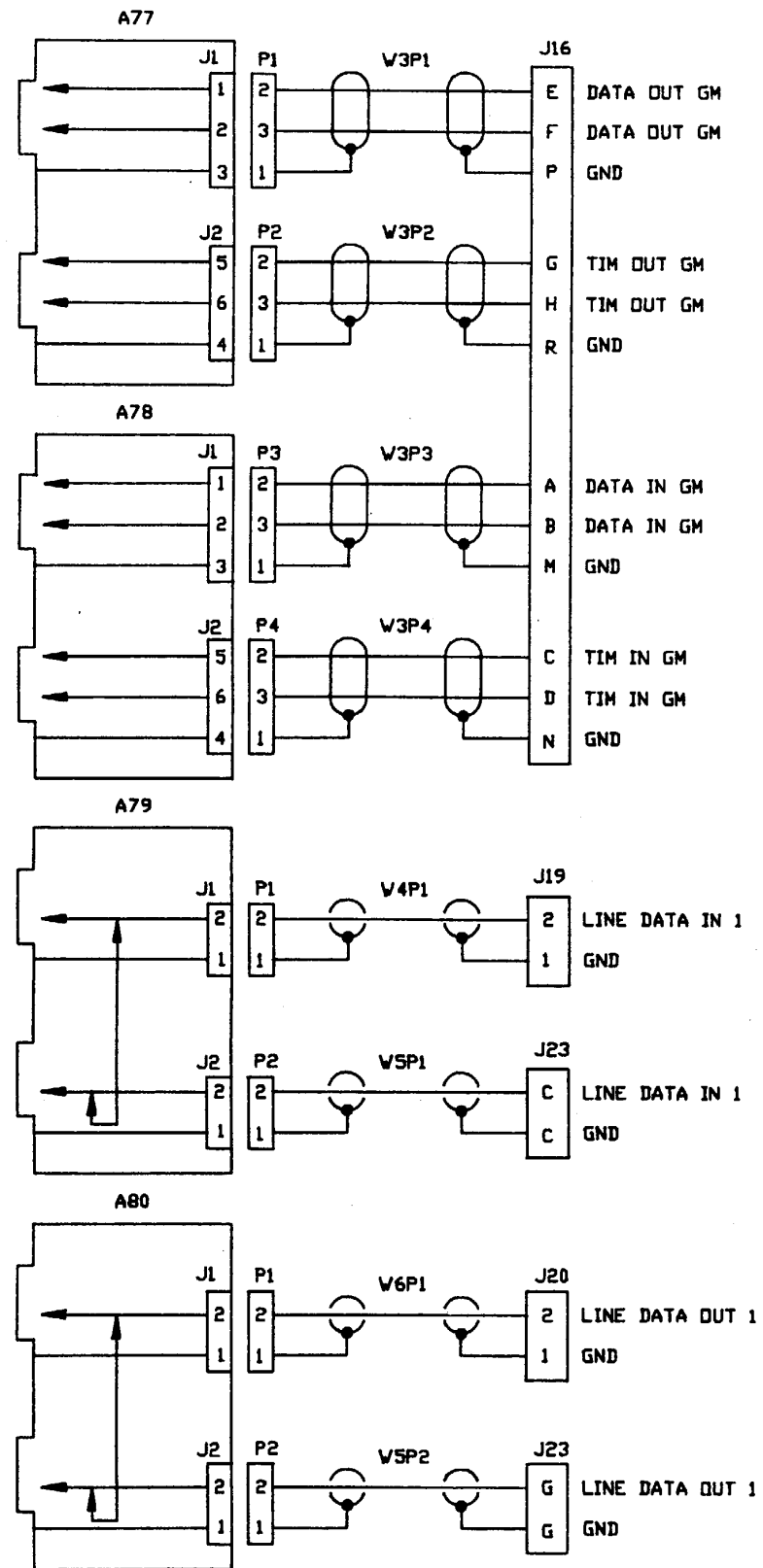

Schematic Diagram, Black Patch Panel - ANITY-30
 (Sheet 6 of 6)

A3093171

NOTE: DATA MARKED WITH AN ASTERISK (*) IS PECULIAR TO A PRIOR MANUFACTURER. IT DOES NOT TAKE PRECEDENCE OVER ANY OTHER DATA ON THIS DRAWING, AND IS NOT CONTRACTUALLY BINDING ON EITHER THE CONTRACTOR OR THE GOVERNMENT.

THIS DOCUMENT HAS BEEN PURCHASED BY THE GOVERNMENT AND MAY BE REPRODUCED AND USED IN CONNECTION WITH ANY GOVERNMENT PROCUREMENT OR MAINTENANCE OPERATION.

REVISIONS			
EFF	LTR	NO.	
ALL	A		INC ECN 92862
ALL	B		INC ECN 93205
ALL	C		INC ECN 102415
	D		INC ECN 120051, EFF: 3/15/90
	E		INC ECN 131491
	F		REPLACES REV E WITH CHANGE PER ECN 135238
	G		INC ECN 142656

REV	F	F	F	F	F	F	F	F	F	F	F	F	F	F	F	G	F						
SHEET	22	23	24	25	26	27	28	29	30	31	32	33	34	35	36	37	38						
REV STATUS OF SHEETS	REV SHEET	G	G	G	G	G	G	G	G	-	A	-	-	-	-	-	F	F	F	F	F	F	F
		1	2	3	4	5	6	7	8	9	10	11	12	13	14	15	16	17	18	19	20	21	

1. PREPARED IN ACCORDANCE WITH DOD-STD-100. 2. UNLESS OTHERWISE SPECIFIED, DIMENSIONS ARE IN INCHES.		ELECTROSPACE SYSTEMS, INC. DAAB07-86-C-J008				U.S. ARMY COMMUNICATIONS - ELECTRONIC COMMAND FORT MONMOUTH, NEW JERSEY 07703															
		APVD	M. MARTIN		11/19/92	DRAWING TITLE WIRING LIST, POINT-TO-POINT, BLACK PATCH PANEL, AN/TYQ30															
		ENGR	C. PYBUS		11/19/92																
		ENGR	E. von ADELUNG		11/19/92																
		CHECK	L. FETZER		11/19/92																
		DRAWN	L. CHATELAIN		11/19/92	SIZE		FSCM NO.			DRAWING NO.										
A3093170	DLA3093170	APVD	R. RICCELLI (ED-MX)		11/19/92	A		80063			A3093172										
NEXT ASSY	USED ON	DATE			11-23-92	SCALE		NONE			G		SHEET 1 OF 38								

- NOTES:
- REFER TO FIGURE 1 FOR PIN ASSIGNMENT OF BACK TO BACK VF JACKS. SOLDER ALL CONNECTIONS. SLEEVE ALL SOLDER CONNECTIONS WITH CLEAR SLEEVING (ITEM 22).
 - REFER TO FIGURE 2 FOR PIN ASSIGNMENTS OF SINGLE VF JACKS. SOLDER ALL CONNECTIONS. SLEEVE ALL SOLDER CONNECTIONS WITH CLEAR SLEEVING (ITEM 22).
 - CRIMP CONTACTS USING CRIMP TOOL M22520/1-01 WITH POSITIONER M22520/1-04BL.. USE INSERTION/EXTRACTION TOOL M81969/14-03. REF MIL-C-22520 & MIL-I-81969.
 - CRIMP CONTACTS USING CRIMP TOOL M22520/1-01 WITH POSITIONER M22520/7-02. USE INSERTION TOOL M81969/14-02 AND EXTRACTION TOOL M81969/19-07. REF MIL-C-22520 & MIL-I-81969.
 - TO CRIMP INNER CONTACT USE M22520/2-01 WITH POSITIONER M22520/2-35. TO CRIMP OUTER CONTACT USE M22520/4-01 WITH POSITIONER M22520/4-02. THE INSERTION/EXTRACTION TOOL IS M81969/14-03. REF MIL-C-22520 & MIL-I-81969.
 - REMOVE INSULATION 1 1/2 TO 2 INCHES PAST SHIELD. PLACE SOLDER FERRULE OVER SHIELD AND APPLY HEAT GUN UNTIL SOLDER FLOWS. DO NOT MOVE WIRES WHILE HOT. SEE FIGURE 4.
 - DO NOT TERMINATE YET. THIS SHIELD IS TO BE DAISY-CHAINED.
 - THIS IS THE FINAL SHIELD TO BE TERMINATED HERE. PIGTAIL THE TWO SHIELDS WITH THEIR 22 AWG JUMPER-WIRE AND THEIR TWO SOLDER FERRULES. TERMINATE WIRE WITH CONTACT PER NOTE 3. SEE FIGURE 5.
 - QUANTITIES ON PARTS LIST ARE ALL IN FEET.
 - PIN CONFIGURATION PER FIGURE 3.
 - SEE SHEETS 3 AND 4 FOR FIGURES IN NOTE 11.

A3093172	THIS DOCUMENT HAS BEEN PURCHASED BY THE GOVERNMENT AND MAY BE REPRODUCED AND USED IN CONNECTION WITH ANY GOVERNMENT PROCUREMENT OR MAINTENANCE OPERATION			SIZE	FSCM NO.	DRAWING NO.
				A	80063	A3093172
				SCALE	NONE	LTR
						G
						SHEET 2

WIRING LIST, POINT-TO-POINT, BLACK PATCH PANEL, AN/TYQ-30
(Sheets 1 & 2 of 37)

NOTES (CONT):

- 13. DELETED.
- 14. SCHEMATIC IS DRAWING NO. A3093171.
- 15. CRIMP COAX PIN BARREL USING CRIMP TOOL M22520/4-01 WITH POSITIONER M22520/4-02. CRIMP INNER PIN USING CRIMP TOOL M22520/2-01 WITH POSITIONER M22520/2-35. REF MIL-C-22520.
- 16. CRIMP RG-178 COAX SLEEVE USING TOOL M22520/5-01 WITH DIE 44-233.
- 17. CRIMP K-GRIP SLEEVE USING TOOL M22520/5-01 WITH DIE Y205-A. REF MIL-C-22520.
- 18. WIRE LENGTHS SHALL HAVE A TOLERANCE OF -0, +1 INCHES.

THIS DOCUMENT HAS BEEN PURCHASED BY THE GOVERNMENT AND MAY BE REPRODUCED AND USED IN CONNECTION WITH ANY GOVERNMENT PROCUREMENT OR MAINTENANCE OPERATION	SIZE A	FSCM NO. 80063	DRAWING NO. A3093172		
	SCALE	NONE	LTR	G	SHEET 3

NOTE 11 (CONTINUED): ASSEMBLE PER THE FOLLOWING PROCEDURES, REFER TO FIGURE 6 FOR PIN ASSIGNMENTS.

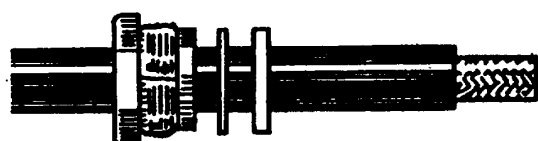
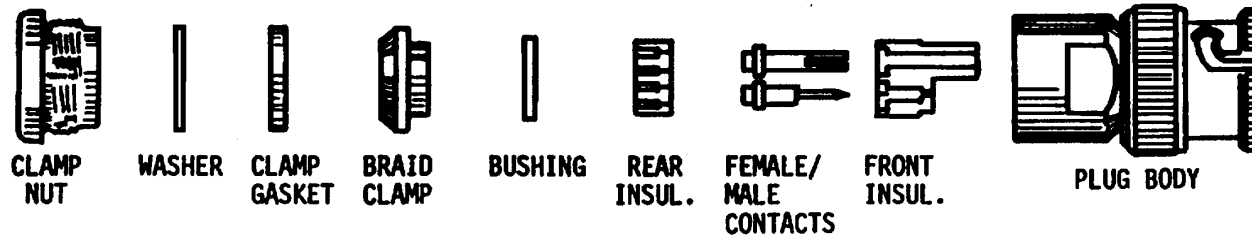

CUT END OF CABLE SHARP AND SQUARE. SLIDE CLAMP NUT, WASHER AND CLAMP GASKET OVER JACKET. CUT OFF JACKET 3/8 INCHES (9.5) FROM END. DO NOT NICK BRAID.

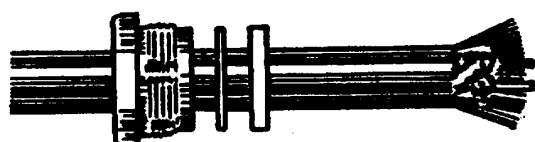

COMB OUT BRAID AND FOLD OUT. CUT OFF CABLE DIELECTRICS 13/64 INCHES (5.2) FROM END OF JACKET, BARING CONDUCTORS.

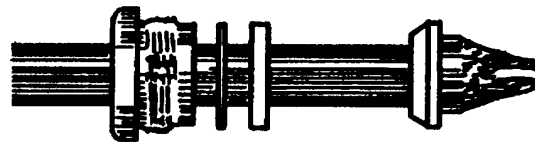

PULL BRAID WIRE FORWARD AND TAPER TOWARD CONDUCTORS. SLIDE BRAID CLAMP OVER BRAID AND PUSH AGAINST CABLE JACKET.

A3093172

THIS DOCUMENT HAS BEEN PURCHASED BY THE GOVERNMENT AND MAY BE REPRODUCED AND USED IN CONNECTION WITH ANY GOVERNMENT PROCUREMENT OR MAINTENANCE OPERATION	SIZE A	FSCM NO. 80063	DRAWING NO. A3093172		
	SCALE	NONE	LTR	G	SHEET 4

NOTE 11 (CONTINUED):

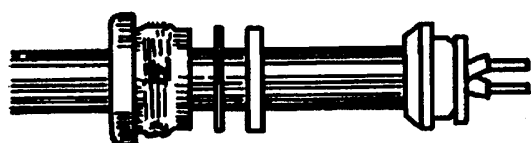

FOLD BACK BRAID WIRES, TRIM TO PROPER LENGTH AND EVENLY FORM OVER BRAID CLAMP AS SHOWN. SLIDE ON BUSHING. TIN CENTER CONDUCTORS USING MINIMUM AMOUNT OF HEAT.



BEND CONDUCTORS OUT AS NECESSARY FOR ALIGNMENT AND SLIDE ON REAR INSULATOR. SOLDER CONTACTS. REMOVE ANY EXCESS SOLDER FROM CONTACT O.D.

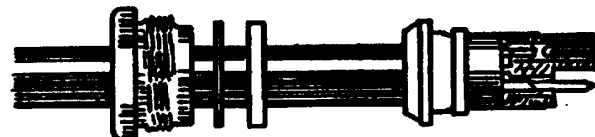

SLIDE FRONT INSULATOR OVER CONTACTS AND BUTT AGAINST CONTACT SHOULDERS AS SHOWN.

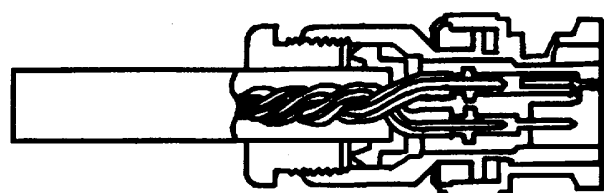

INSERT PREPARED CABLE TERMINATION INTO CONNECTOR BODY. MAKE SURE SHARP EDGE OF ARMOR CLAMP SEATS PROPERLY IN GASKET. TIGHTEN NUT SECURELY.

THIS DOCUMENT HAS BEEN PURCHASED BY THE GOVERNMENT AND MAY BE REPRODUCED AND USED IN CONNECTION WITH ANY GOVERNMENT PROCUREMENT OR MAINTENANCE OPERATION	SIZE	FSCM NO.	DRAWING NO.	
	A	80063	A3093172	
	SCALE	NONE	LTR	G SHEET 5

NOTE 12 (CONTINUED): ASSEMBLE THE FOLLOWING PROCEDURES, REFER TO FIGURE 7 FOR PIN ASSIGNMENTS.

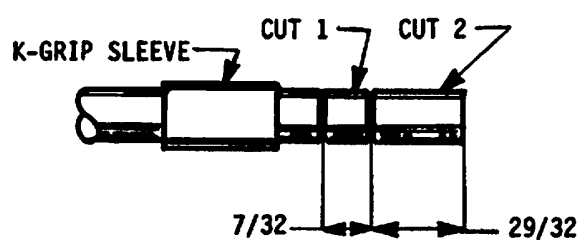

1. CUT CABLE END SQUARE, SLIDE K-GRIP SLEEVE OVER JACKET AND WITH JACKET TRIM JIG, MAKE CUTS 1 AND 2 IN JACKET.



2. REMOVE JACKET 29/32, FLARE OR BULGE BACK BRAID AND TRIM WITH SCISSORS AT EDGE OF JACKET.

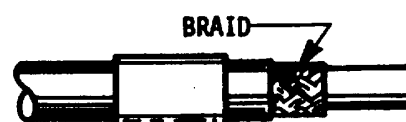

3. REMOVE JACKET 7/32.

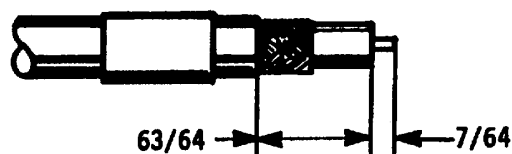

4. USING DIELECTRIC TRIM JIG, TRIM DIMENSION "C". EXPOSED CENTER CONDUCTOR LENGTH WILL BE EQUAL TO DIMENSION "D" OF TRIM CODE. WHEN DIELECTRIC BUSHING IS USED, ADJUST TRIM CODE AS SHOWN BELOW.

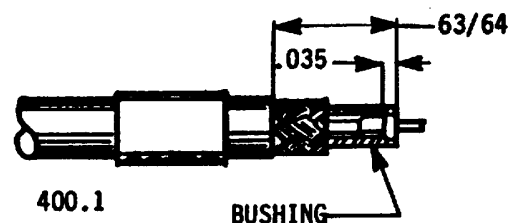

A3093172	THIS DOCUMENT HAS BEEN PURCHASED BY THE GOVERNMENT AND MAY BE REPRODUCED AND USED IN CONNECTION WITH ANY GOVERNMENT PROCUREMENT OR MAINTENANCE OPERATION	SIZE	FSCM NO.	DRAWING NO.	
		A	80063	A3093172	
		SCALE	NONE	LTR	G SHEET 6

NOTE 12 (CONTINUED):



5. SOLDER OR CRIMP CONTACT TO CENTER CONDUCTOR.

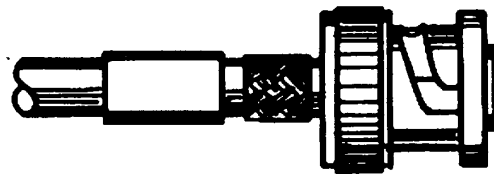

6. PUSH K-GRIP JR. OVER DIELECTRIC AND UNDER BRAID UNTIL DIELECTRIC BOTTOMS IN CONNECTOR.

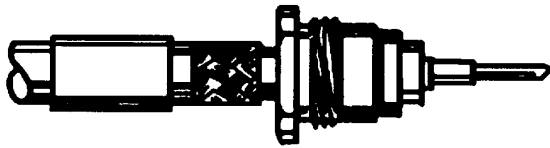

5A. PUSH PRE-ASSEMBLED K-GRIP OVER DIELECTRIC AND UNDER BRAID, UNTIL DIELECTRIC BOTTOMS IN CONNECTOR. SOLDER OR CRIMP CONTACT TO CENTER CONDUCTOR. PROCEED TO STEP 7A.

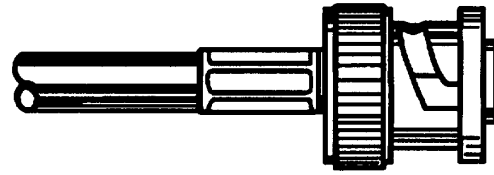

7. SLIDE K-GRIP SLEEVE AGAINST SHOULDER ON BODY AND FORM HEX BY CRIMPING. WHEN SHRINK TUBING IS SUPPLIED, SHRINK OVER BODY AND CABLE BY HEATING (300°F MAXIMUM). INSTALL INTERFACE GASKET OVER CENTER CONTACT WHEN SUPPLIED.

WHEN SUPPLIED, CABLE SEAL GASKET FOR 10 AND 20KV CONNECTORS



5B. PLACE CABLE SEAL GASKET OVER CENTER CONDUCTOR AND AGAINST DIELECTRIC. SOLDER CONTACT TO CENTER CONDUCTOR WITH GASKET UNDER COMPRESSION.

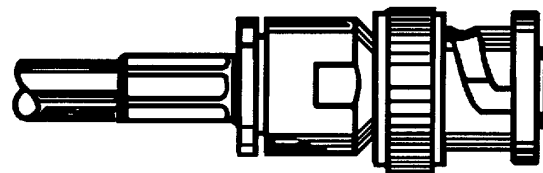

7A. SLIDE K-GRIP SLEEVE AGAINST SHOULDER ON BODY AND FORM HEX BY CRIMPING. THREAD CONNECTOR ONTO ASSEMBLY AND TIGHTEN SECURELY.

0359N-2	THIS DOCUMENT HAS BEEN PURCHASED BY THE GOVERNMENT AND MAY BE REPRODUCED AND USED IN CONNECTION WITH ANY GOVERNMENT PROCUREMENT OR MAINTENANCE OPERATION	SIZE	FSCM NO.	DRAWING NO.	
		A	80063	A3093172	
		SCALE	NONE	LTR	G SHEET 7

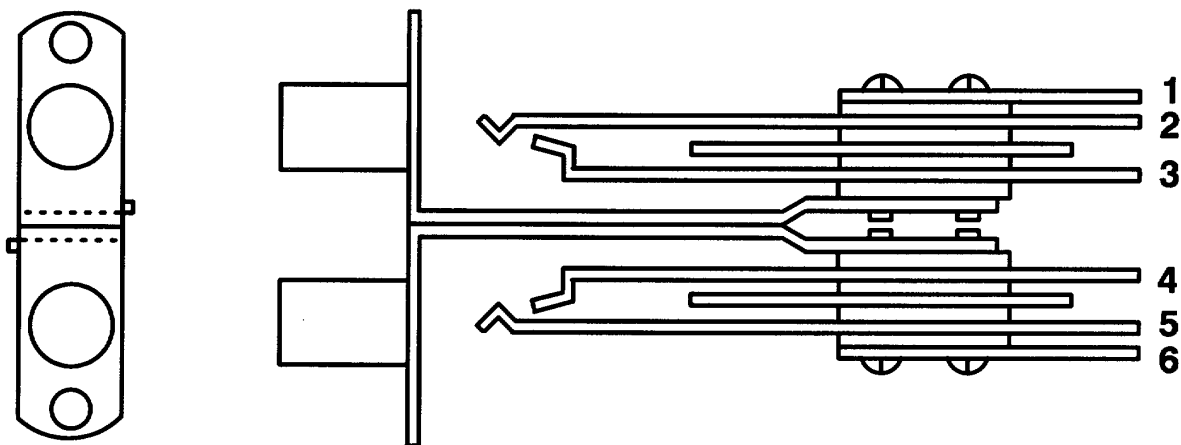

FIGURE 1

A3093172	THIS DOCUMENT HAS BEEN PURCHASED BY THE GOVERNMENT AND MAY BE REPRODUCED AND USED IN CONNECTION WITH ANY GOVERNMENT PROCUREMENT OR MAINTENANCE OPERATION	SIZE	FSCM NO.	DRAWING NO.	
		A	80063	A3093172	
		SCALE	NONE	LTR	-

WIRING LIST, POINT-TO-POINT, BLACK PATCH PANEL, AN/TYQ-30
(Sheets 7 & 8 of 37)

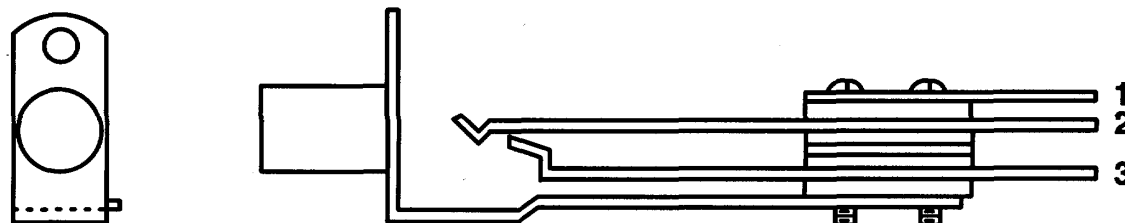

FIGURE 2

THIS DOCUMENT HAS BEEN PURCHASED BY THE GOVERNMENT AND MAY BE REPRODUCED AND USED IN CONNECTION WITH ANY GOVERNMENT PROCUREMENT OR MAINTENANCE OPERATION	SIZE	FSCM NO.	DRAWING NO.	
	A	80063	A3093172	
	SCALE	NONE	LTR	A SHEET 9

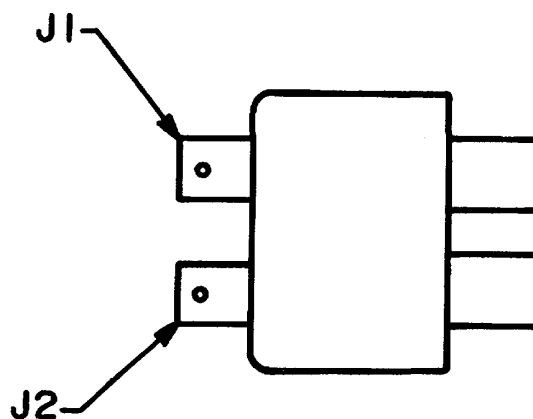

FIGURE 3

A3093172	THIS DOCUMENT HAS BEEN PURCHASED BY THE GOVERNMENT AND MAY BE REPRODUCED AND USED IN CONNECTION WITH ANY GOVERNMENT PROCUREMENT OR MAINTENANCE OPERATION	SIZE	FSCM NO.	DRAWING NO.	
		A	80063	A3093172	
		SCALE	NONE	LTR	A SHEET 10

WIRING LIST, POINT-TO-POINT, BLACK PATCH PANEL, AN/TYQ-30
(Sheets 9 & 10 of 37)

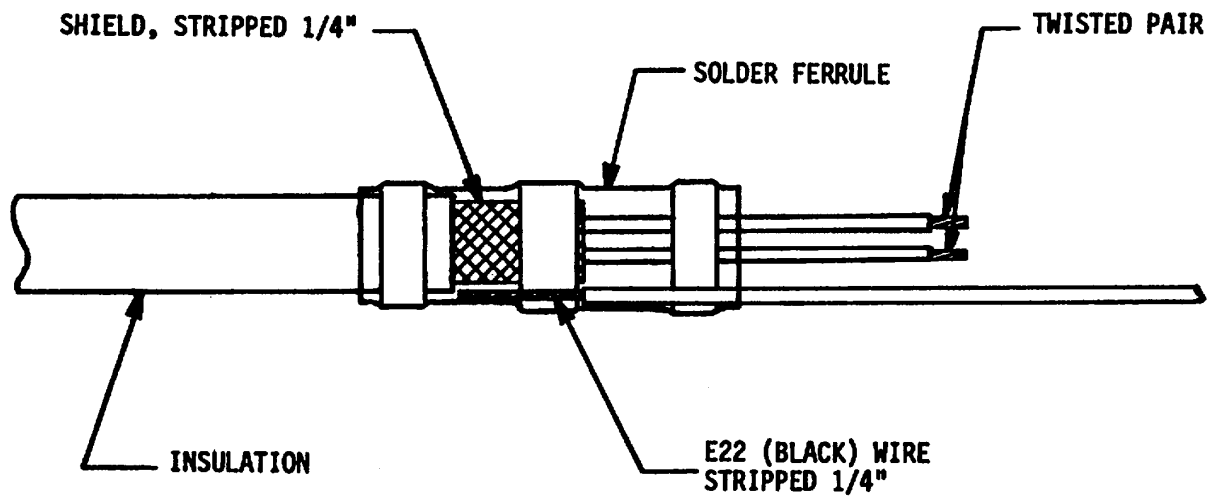

FIGURE 4

THIS DOCUMENT HAS BEEN PURCHASED BY THE GOVERNMENT AND MAY BE REPRODUCED AND USED IN CONNECTION WITH ANY GOVERNMENT PROCUREMENT OR MAINTENANCE OPERATION

SIZE
A

FSCM NO.
80063

DRAWING NO.
A3093172

SCALE

NONE

LTR -

SHEET

11

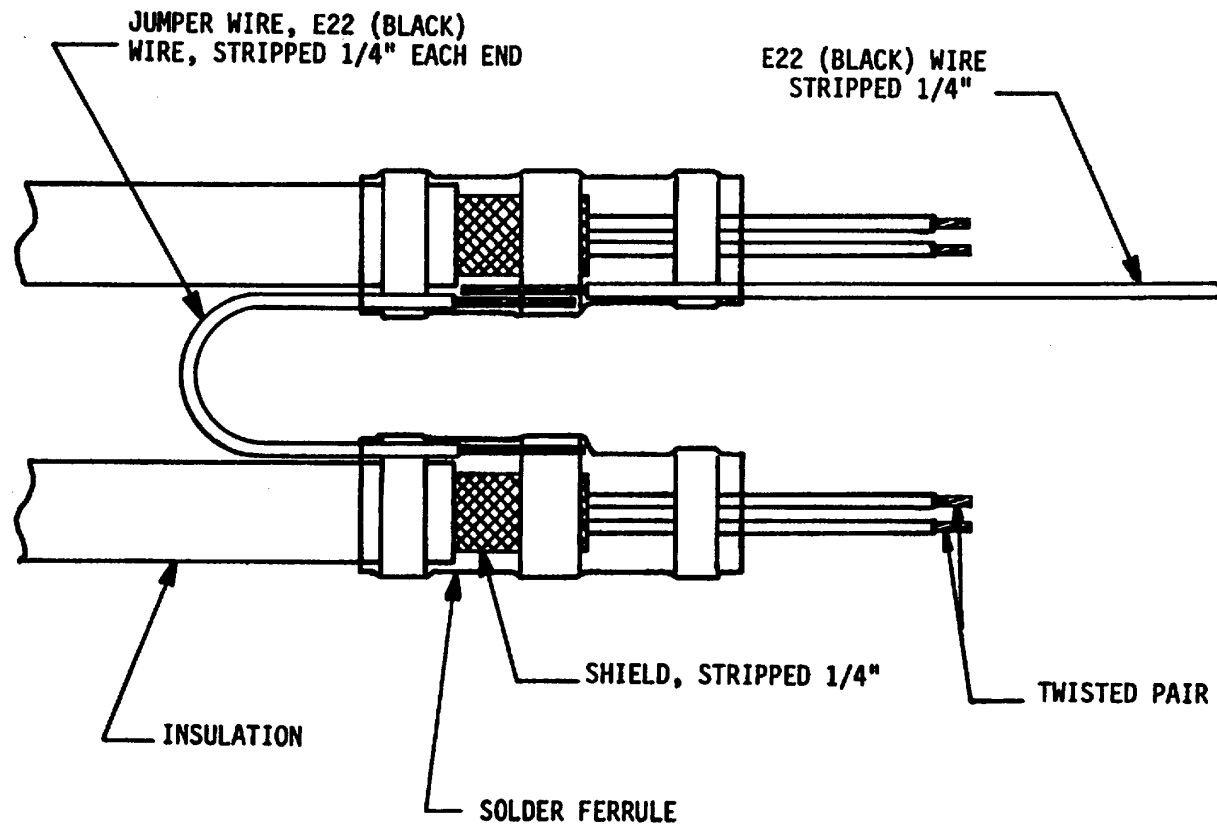

FIGURE 5

THIS DOCUMENT HAS BEEN PURCHASED BY THE GOVERNMENT AND MAY BE REPRODUCED AND USED IN CONNECTION WITH ANY GOVERNMENT PROCUREMENT OR MAINTENANCE OPERATION

SIZE
A

FSCM NO.
80063

DRAWING NO.
A3093172

SCALE

NONE

LTR -

SHEET

12

A3093172

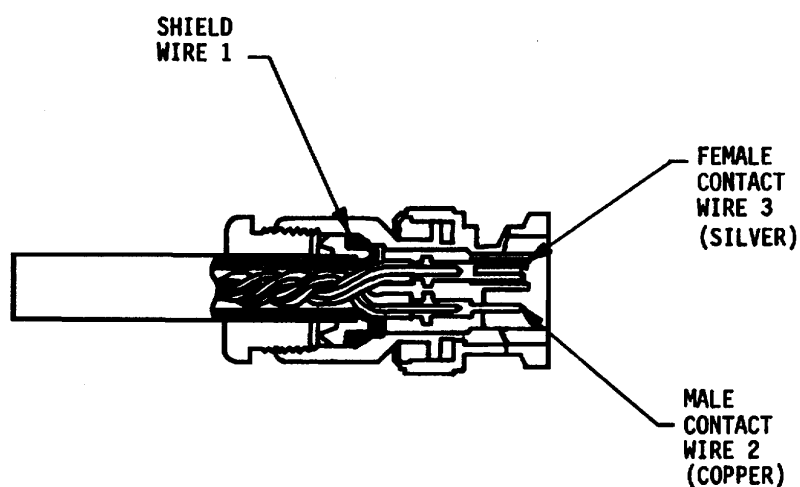

FIGURE 6

THIS DOCUMENT HAS BEEN PURCHASED BY THE GOVERNMENT AND MAY BE REPRODUCED AND USED IN CONNECTION WITH ANY GOVERNMENT PROCUREMENT OR MAINTENANCE OPERATION	SIZE	FSCM NO.	DRAWING NO.	
	A	80063	A3093172	
	SCALE	NONE	LTR -	SHEET 13

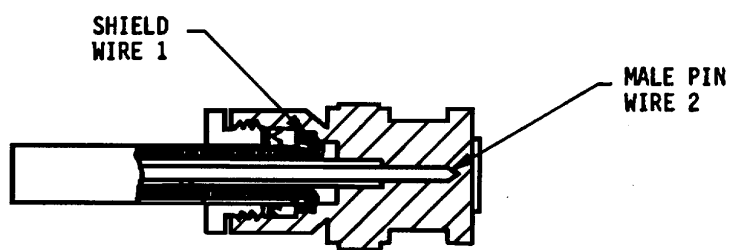

FIGURE 7

THIS DOCUMENT HAS BEEN PURCHASED BY THE GOVERNMENT AND MAY BE REPRODUCED AND USED IN CONNECTION WITH ANY GOVERNMENT PROCUREMENT OR MAINTENANCE OPERATION	SIZE	FSCM NO.	DRAWING NO.	
	A	80063	A3093172	
	SCALE	NONE	LTR -	SHEET 14

PARTS LIST					
QTY	ITEM	PART NO.	DESCRIPTION	SPEC/STD	FSCM NO.
12	1	A3093530	CONNECTOR, BNC TWINAX		80063
REF	2	A3093567-3	CONNECTOR, BNC (J19, J21)		80063
REF	3	A3093567-4	CONNECTOR, BNC (J20, J22)		80063
5	4	M16878/4BFB0	WIRE, 22 AWG, STRANDED, BLACK	(FT) MIL-W-16878/4	81349
5	5	M16878/4BDB0	WIRE, 26 AWG, STRANDED, BLACK	(FT) MIL-W-16878/4	81349
12	6	M17/028-RG058	COAX WIRE	(FT) MIL-C-17/028	81349
36	7	M17/045-RG108	TWINAX WIRE	(FT) MIL-C-17/045	81349
24	8	M17/93-RG178/V	COAX WIRE (USE W/COAX PINS)	(FT) MIL-C-17/75	81349
309	9	M27500-22TE2T14	WIRE, TWISTED, 22 AWG, SHIELDED	(FT) MIL-C-27500	81349
4	10	M39012/16-0004	CONNECTOR, BNC COAX	MIL-C-39012/16	81349
14	11	M39029/58-364	CONTACT, CRIMP, NO. 16	MIL-C-39029/58	81349
8	12	M39029/76-424	CONTACT COAXIAL	MIL-C-39029/76	81349
107	13	M83519-2-8	FERRULE, SOLDER	MIL-S-83519	81349
REF	14	MS27468T9B98P	CONNECTOR, CIRCULAR (J27)		96906
REF	15	MS27468T9B98S	CONNECTOR, CIRCULAR (J28)		96906
REF	16	MS27474T12B3A	CONNECTOR, CIRCULAR (J25, J26)		96906

0359N-2	THIS DOCUMENT HAS BEEN PURCHASED BY THE GOVERNMENT AND MAY BE REPRODUCED AND USED IN CONNECTION WITH ANY GOVERNMENT PROCUREMENT OR MAINTENANCE OPERATION	SIZE A	FSCM NO. 80063	DRAWING NO. A3093172	
		SCALE NONE	LTR F	SHEET	15

PARTS LIST					
QTY	ITEM	PART NO.	DESCRIPTION	SPEC/STD	FSCM NO.
REF	17	MS27474T16B8A	CONNECTOR, CIRCULAR (J23, J24)		96906
REF	18	MS3124F12-10S	CONNECTOR, CIRCULAR (J17, J18)		96906
REF	19	MS3124F12-8P	CONNECTOR, CIRCULAR (J1-J10)		96906
REF	20	MS3124F14-18P	CONNECTOR, CIRCULAR (J14, J15, J16)		96906
REF	21	MS3124F22-55P	CONNECTOR, CIRCULAR (J11, J12, J13, J29)		96906
25	22	M23053/4-201-C	INSULATION SLEEVING	MIL-I-23053/4	81349
8	23	A3092982	CONNECTOR, AMP 330876		80063
12	24	A3093335-5	FERRULE, SOLDER		80063

THIS DOCUMENT HAS BEEN PURCHASED BY THE GOVERNMENT AND MAY BE REPRODUCED AND USED IN CONNECTION WITH ANY GOVERNMENT PROCUREMENT OR MAINTENANCE OPERATION	SIZE A	FSCM NO. 80063	DRAWING NO. A3093172	
	SCALE NONE	LTR F	SHEET	16 16

A3093172

WIRING LIST, POINT-TO-POINT, BLACK PATCH PANEL,
AN/TYQ-30
(Sheets 15 & 16 of 37)

WIRE NO. OR COLOR	FROM TERMINATION			TO TERMINATION			WIRE		FUNCTION	REMARKS
	REF DES	PIN	(I) ITEM (N) NOTE	REF DES	PIN	(I) ITEM (N) NOTE	ITEM	LENGTH		
1	A1	1	I13N1N6	J1	C	I13119N3N6	9	36 IN	GND	KY-68/LGM
2 BLU	A1	2	N1	J1	A	I19 N3	9	36 IN	WLTX-N CH 1	KY-68/LGM
3 WHT	A1	3	N1	J1	B	I19 N3	9	36 IN	WLTX-P CH 1	KY-68/LGM
4 BLU	A1	4	N1	J11	W	I21 N3	9	36 IN	DATA IN CH 1	KY-68/LGM
5 WHT	A1	5	N1	J11	X	I21 N3	9	36 IN	DATA IN CH 1	KY-68/LGM
6	A1	6	I13N1N6	J11	p	I13121N7N6	9	36 IN	GND	KY-68/LGM
7	A2	1	I13N1N6	J1	F	I13119N3N6	9	36 IN	GND	KY-68/LGM
8 BLU	A2	2	N1	J1	D	I19 N3	9	36 IN	WLRX-N CH 1	KY-68/LGM
9 WHT	A2	3	N1	J1	E	I19 N3	9	36 IN	WLRX-P CH 1	KY-68/LGM
10 BLU	A2	4	N1	J11	B	I21 N3	9	36 IN	DATA OUT CH 1	KY-68/LGM
11 WHT	A2	5	N1	J11	C	I21 N3	9	36 IN	DATA OUT CH 1	KY-68/LGM
12	A2	6	I13N1N6	J11	p	I13121N3N8N69	9	36 IN	GND	KY-68/LGM
13	A3	1	I13N1N6	J2	C	I13119N3N6	9	36 IN	GND	KY-68/LGM
14 BLU	A3	2	N1	J2	A	I19 N3	9	36 IN	WLTX-N CH 2	KY-68/LGM
15 WHT	A3	3	N1	J2	B	I19 N3	9	36 IN	WLTX-P CH 2	KY-68/LGM
16 BLU	A3	4	N1	J11	AA	I21 N3	9	36 IN	DATA IN CH2	KY-68/LGM
17 WHT	A3	5	N1	J11	BB	I21 N3	9	36 IN	DATA IN CH 2	KY-68/LGM

0359N-2

MAINTENANCE OPERATION

SCALE

NONE

LTR

D

SHEET

17

WIRE NO. OR COLOR	FROM TERMINATION			TO TERMINATION			WIRE		FUNCTION	REMARKS
	REF DES	PIN	(I) ITEM (N) NOTE	REF DES	PIN	(I) ITEM (N) NOTE	ITEM	LENGTH		
18	A3	6	I13N1N6	J11	GG	I13121N7N6	9	36 IN	GND	KY-68/LGM
19	A4	1	I13N1N6	J2	F	I13119N3N6	9	36 IN	GND	KY-68/LGM
20 BLU	A4	2	N1	J2	D	I19 N3	9	36 IN	WLRX-N CH 2	KY-68/LGM
21 WHT	A4	3	N1	J2	E	I19 N3	9	36 IN	WLRX-P CH 2	KY-68/LGM
22 BLU	A4	4	N1	J11	q	I21N3	9	36 IN	DATA OUT CH 2	KY-68/LGM
23 WHT	A4	5	N1	J11	z	I21 N3	9	36 IN	DATA OUT CH 2	KY-68/LGM
24	A4	6	I13N1N6	J11	GG	I13121N3N8N6	9	36 IN	GND	KY-68/LGM
25	A5	1	I13N1N6	J3	C	I13119N3N6	9	36 IN	GND	KY-68/LGM
26 BLU	A5	2	N1	J3	A	I19 N3	9	36 IN	WLTX-N CH 3	KY-68/LGM
27 WHT	A5	3	N1	J3	B	I19 N3	9	36 IN	WLTX-P CH 3	KY-68/LGM
28 BLU	A5	4	N1	J11	Z	I21 N3	9	36 IN	DATA IN CH 3	KY-68/LGM
29 WHT	A5	5	N1	J11	r	I21 N3	9	36 IN	DATA IN CH3	KY-68/LGM
30	A5	6	I13N1N6	J11	CC	I13121N7N6	9	36 IN	GND	KY-68/LGM
31	A6	1	I13N1N6	J3	F	I13119N3N6	9	36 IN	GND	KY-68/LGM
32 BLU	A6	2	N1	J3	D	I19 N3	9	36 IN	WLRX-N CH 3	KY-68/LGM
33 WHT	A6	3	N1	J3	E	I19 N3	9	36 IN	WLRX-P CH 3	KY-68/LGM
34 RBLJ	AR	4	N1	J11	D	I21 N3	9	36 IN	DATA OUT CH 3	KY-68/LGM

THIS DOCUMENT HAS BEEN PURCHASED BY THE GOVERNMENT AND MAY BE REPRODUCED AND USED IN CONNECTION WITH ANY GOVERNMENT PROCUREMENT OR MAINTENANCE OPERATION	SIZE	FSCM NO.	DRAWING NO.	
	A	80063	A3093172	
SCALE	NONE	LTR	D	SHEET
				18

A3093172

WIRING LIST, POINT-TO-POINT, BLACK PATCH PANEL, AN/TYQ-30 (Sheets 17 & 18 of 37)

WIRE NO. OR COLOR	FROM TERMINATION			TO TERMINATION			WIRE		FUNCTION	REMARKS
	REF DES	PIN	(I) ITEM (N) NOTE	REF DES	PIN	(I) ITEM (N) NOTE	ITEM	LENGTH		
35 WHT	A6	5	N1	J11	Y	I21 N3	9	36 IN	DATA OUT CH 3	KY-68/LGM
36	A6	6	I13N1N6	J11	CC	I13121N3N8N6	9	36 IN	GND	KY-68/LGM
37	A7	1	I13N1N6	J4	C	I13119N3N6	9	36 IN	GND	KY-68/LGM
38 BLU	A7	2	N1	J4	A	I19 N3	9	36 IN	WLTX-N CH 4	KY-68/LGM
39 WHT	A7	3	N1	J4	B	I19 N3	9	36 IN	WLTX-P CH 4	KY-68/LGM
40 BLU	A7	4	N1	J11	i	I21 N3	9	36 IN	DATA IN CH 4	KY-68/LGM
41 WHT	A7	5	N1	J11	j	I21 N3	9	36 IN	DATA INCH 4	KY-68/LGM
42	A7	6	I13N1N6	J11	y	I13121N7N6	9	36 IN	GND	KY-68/LGM
43	A8	1	I13N1N6	J4	F	I13119N3N6	9	36 IN	GND	KY-68/LGM
44 BLU	A8	2	N1	J4	D	I19 N3	9	36 IN	WLRX-N CH 4	KY-68/LGM
45 WHT	A8	3	N1	J4	E	I19 N3	9	36 IN	WLRX-P CH 4	KY-68/LGM
46 BLU	A8	4	N1	J11	N	I21 N3	9	36 IN	DATA OUT CH 4	KY-68/LGM
47 WHT	A8	5	N1	J11	P	I21 N3	9	36 IN	DATA OUT CH 4	KY-68/LGM
48	A8	6	I13N1N6	J11	y	I13121N3N8N6	9	36 IN	GND	KY-68/LGM
49	A9	1	I13N1N6	J5	C	I13119N3N6	9	36 IN	GND	KY-68/LGM
50 BLU	A9	2	N1	J5	A	I19N3	9	36 IN	WLTX-N CH 5	KY-68/LGM
51 WHT	A9	3	N1	J5	B	I19N3	9	36 IN	WLTX-P CH 5	KY-68/LGM

0359N-2	THIS DOCUMENT HAS BEEN PURCHASED BY THE GOVERNMENT AND MAY BE REPRODUCED AND USED IN CONNECTION WITH ANY GOVERNMENT PROCUREMENT OR MAINTENANCE OPERATION	SIZE	FSCM NO.	DRAWING NO.			
		A	80063	A3093172			
		SCALE	NONE	LTR	D	SHEET	9

WIRE NO. OR COLOR	FROM TERMINATION			TO TERMINATION			WIRE		FUNCTION	REMARKS
	REF DES	PIN	(I) ITEM (N) NOTE	REF DES	PIN	(I) ITEM (N) NOTE	ITEM	LENGTH		
52 BLU	A9	4	N1	J11	EE	I21 N3	9	36 IN	DATA IN CH 5	KY-68/LGM
53 WHT	A9	5	N1	J11	FF	I21 N3	9	36 IN	DATA IN CH 5	KY-68/LGM
54	A9	6	I13N1N6	J11	HH	I13121N7N6	9	36 IN	GND	KY-68/LGM
55	A10	1	I13N1N6	J5	F	I13119N3N6	9	36 IN	GND	KY-68/LGM
56 BLU	A10	2	N1	J5	D	I19 N3	9	36 IN	WLRX-N CH 5	KY-68/LGM
57 WHT	A10	3	N1	J5	E	I19 N3	9	36 IN	WLRX-P CH 5	KY-68/LGM
58 BLU	A10	4	N1	J11	s	I21 N3	9	36 IN	DATA OUT CH5	KY-68/LGM
59 WHT	A10	5	N1	J11	DD	I21 N3	9	36 IN	DATA OUT CH 5	KY-68/LGM
60	A10	6	I13N1N6	J11	HH	I13121N3N8N6	9	36 IN	GND	KY-68/LGM
61	A11	1	I13N1N6	J6	C	I13119N3N6	9	36 IN	GND	KY-68/LGM
62 BLU	A11	2	N1	J6	A	I19 N3	9	36 IN	WLTX-N CH 6	KY-68/LGM
63 WHT	A11	3	N1	J6	B	I19 N3	9	36 IN	WLTX-P CH 6	KY-68/LGM
64 BLU	A11	4	N1	J11	a	I21 N3	9	36 IN	DATA IN CH 6	KY-68/LGM
65 WHT	A11	5	N1	J11	b	I21 N3	9	36 IN	DATA IN CH 6	KY-68/LGM
66	A11	6	I13N1N6	J11	t	I13121N7N6	9	36 IN	GND	KY-68/LGM
67	A12	1	I13N1N6	J6	F	I13119N3N6	9	36 IN	GND	KY-68/LGM
68 BLU	A12	2	N1	J6	D	I19 N3	9	36 IN	WLRX-N CH 6	KY-68/LGM

THIS DOCUMENT HAS BEEN PURCHASED BY THE GOVERNMENT AND MAY BE REPRODUCED AND USED IN CONNECTION WITH ANY GOVERNMENT PROCUREMENT OR MAINTENANCE OPERATION	SIZE	FSCM NO.	DRAWING NO.				
	A	80063	A3093172				
		SCALE	NONE	LTR	D	SHEET	20

WIRING LIST, POINT-TO-POINT, BLACK PATCH PANEL, AN/TYQ-30 (Sheets 19 & 20 of 37)

WIRE NO. OR COLOR	FROM TERMINATION			TO TERMINATION			WIRE		FUNCTION	REMARKS
	REF DES	PIN	(I) ITEM (N) NOTE	REF DES	PIN	(I) ITEM (N) NOTE	ITEM	LENGTH		
69 WHT	A12	3	N1	J6	E	I19 N3	9	36 IN	WLRX-P CH 6	KY-68/LGM
70 BU	A12	4	N1	J11	E	I21 N3	9	36 IN	DATA OUT CH 6	KY-68/LGM
71 WHT	A12	5	N1	J11	F	I21 N3	9	36 IN	DATA OUT CH 6	KY-68/LGM
72	A12	6	I13N1N6	J11	t	I13I21N3N8N69	9	36 IN	GND	KY-68/LGM
73 BLU	A13	2	N2	J13	A	I21 N3	9	36 IN	DATA IN CH 1	SWITCH
74 WHT	A13	3	N2	J13	B	I21 N3	9	36 IN	DATA IN CH1	SWITCH
75 BLU	A14	2	N2	J13	C	I21 N3	9	36 IN	DATA OUT CH 1	SWITCH
76 WHT	A14	3	N2	J13	D	I21 N3	9	36 IN	DATA OUT CH 1	SWITCH
77 BLU	A15	2	N2	J13	E	I21 N3	9	36 IN	DATA IN CH 2	SWITCH
78 WHT	A15	3	N2	J13	F	I21 N3	9	36 IN	DATA IN CH 2	SWITCH
79 BLU	A16	2	N2	J13	G	I21 N3	9	36 IN	DATA OUT CH 2	SWITCH
80 WHT	A16	3	N2	J13	H	I21 N3	9	36 IN	DATA OUT CH 2	SWITCH
81 BLU	A17	2	N2	J13	J	I21 N3	9	36 IN	DATA IN CH 3	SWITCH
82 WHT	A17	3	N2	J13	K	I21 N3	9	36 IN	DATA IN CH 3	SWITCH
83 BLU	A18	2	N2	J13	L	I21 N3	9	36 IN	DATA OUT CH 3	SWITCH
84 WHT	A18	3	N2	J13	M	I21 N3	9	36 IN	DATA OUT CH 3	SWITCH
85 BLU	A19	2	N2	J13	N	I21 N3	9	36 IN	DATA IN CH 4	SWITCH

0359N-2	THIS DOCUMENT HAS BEEN PURCHASED BY THE GOVERNMENT AND MAY BE REPRODUCED AND USED IN CONNECTION WITH ANY GOVERNMENT PROCUREMENT OR MAINTENANCE OPERATION	SIZE	FSCM NO.	DRAWING NO.	
		A	80063	A3093172	
		SCALE	NONE	LTR	B SHEET 21

WIRE NO. OR COLOR	FROM TERMINATION			TO TERMINATION			WIRE		FUNCTION	REMARKS
	REF DES	PIN	(I) ITEM (N) NOTE	REF DES	PIN	(I) ITEM (N) NOTE	ITEM	LENGTH		
86 WHT	A19	3	N2	J13	P	I21 N3	9	36 IN	DATA IN CH 4	SWITCH
87 BLU	A20	2	N2	J13	R	I21 N3	9	36 IN	DATA OUT CH 4	SWITCH
88 WHT	A20	3	N2	J13	S	I21 N3	9	36 IN	DATA OUT CH 4	SWITCH
89 BLU	A21	2	N2	J13	T	I21 N3	9	36 IN	DATA IN CH 5	SWITCH
90 WHT	A21	3	N2	J13	U	I21 N3	9	36 IN	DATA IN CH 5	SWITCH
91 BLU	A22	2	N2	J13	V	I21 N3	9	36 IN	DATA OUT CH 5	SWITCH
92 WHT	A22	3	N2	J13	W	I21 N3	9	36 IN	DATA OUT CH 5	SWITCH
93 BLU	A23	2	N2	J13	X	I21 N3	9	36 IN	DATA IN CH 6	SWITCH
94 WHT	A23	3	N2	J13	Y	I21 N3	9	36 IN	DATA IN CH 6	SWITCH
95 BLU	A24	2	N2	J13	Z	I21 N3	9	36 IN	DATA OUT CH 6	SWITCH
96 WHT	A24	3	N2	J13	a	I21 N3	9	36 IN	DATA OUT CH 6	SWITCH
97 BLU	A25	2	N2	J13	b	I21 N3	9	36 IN	DATA IN CH 7	SWITCH
98 WHT	A25	3	N2	J13	c	I21 N3	9	36 IN	DATA IN CH 7	SWITCH
99 BLU	A26	2	N2	J13	d	I21 N3	9	36 IN	DATA OUT CH 7	SWITCH
100 WHT	A26	3	N2	J13	e	I21 N3	9	36 IN	DATA OUT CH 7	SWITCH
101 BLU	A27	2	N2	J13	f	I21 N3	9	36 IN	DATA IN CH 8	SWITCH
102 WHT	A27	3	N2	J13	g	I21 N3	9	36 IN	DATA IN CH 8	SWITCH

THIS DOCUMENT HAS BEEN PURCHASED BY THE GOVERNMENT AND MAY BE REPRODUCED AND USED IN CONNECTION WITH ANY GOVERNMENT PROCUREMENT OR MAINTENANCE OPERATION	SIZE	FSCM NO.	DRAWING NO.	
	A	80063	A3093172	
		SCALE	NONE	LTR D SHEET 22

WIRING LIST, POINT-TO-POINT, BLACK PATCH PANEL, AN/TYQ-30 (Sheets 21 & 22 of 37)

WIRE NO. OR COLOR	FROM TERMINATION			TO TERMINATION			WIRE		FUNCTION	REMARKS
	REF DES	PIN	(I) ITEM (N) NOTE	REF DES	PIN	(I) ITEM (N) NOTE	ITEM	LENGTH		
103 BLU	A28	2	N2	J13	h	I21 N3	9	36 IN	DATA OUT CH 8	SWITCH
104 WHT	A28	3	N2	J13	k	I21 N3	9	36 IN	DATA OUT CH 8	SWITCH
105 BLU	A29	2	N2	J13	m	I21 N3	9	36 IN	DATA IN CH 9	SWITCH
106 WHT	A29	3	N2	J13	n	I21 N3	9	36 IN	DATA IN CH 9	SWITCH
107 BLU	A30	2	N2	J13	p	I21 N3	9	36 IN	DATA CUT CH 9	SWITCH
108 WHT	A30	3	N2	J13	q	I21 N3	9	36 IN	DATA OUT CH 9	SWITCH
109 BLU	A31	2	N2	J13	r	I21 N3	9	36 IN	DATA IN CH 10	SWITCH
110 WHT	A31	3	N2	J13	s	I21 N3	9	36 IN	DATA IN CH 10	SWITCH
111 BLU	A32	2	N2	J13	t	I21 N3	9	36 IN	DATA OUT CH 10	SWITCH
112 WHT	A32	3	N2	J13	u	I21 N3	9	36 IN	DATA OUT CH 10	SWITCH
113 BLU	A33	2	N2	J13	v	I21 N3	9	36 IN	DATA IN CH 11	SWITCH
114 WHT	A33	3	N2	J13	w	I21 N3	9	36 IN	DATA IN CH 11	SWITCH
115 BLU	A34	2	N2	J13	x	I21 N3	9	36 IN	DATAOUTCH 11	SWITCH
116 WHT	A34	3	N2	J13	y	I21 N3	9	36 IN	DATA OUT CH 11	SWITCH
117 BLU	A35	2	N2	J13	z	I21 N3	9	36 IN	DATA IN CH 12	SWITCH
118 WHT	A35	3	N2	J13	AA	I21 N3	9	36 IN	DATA IN CH 12	SWITCH
119 BLU	A36	2	N2	J13	BB	I21 N3	9	36 IN	DATA OUT CH 12	SWITCH

0359N-2	THIS DOCUMENT HAS BEEN PURCHASED BY THE GOVERNMENT AND MAY BE REPRODUCED AND USED IN CONNECTION WITH ANY GOVERNMENT PROCUREMENT OR MAINTENANCE OPERATION	SIZE	FSCM NO.	DRAWING NO.	
		A	80063	A3093172	
		SCALE	NONE	LTR	B SHEET 23 J

WIRE NO. OR COLOR	FROM TERMINATION			TO TERMINATION			WIRE		FUNCTION	REMARKS
	REF DES	PIN	(I) ITEM (N) NOTE	REF DES	PIN	(I) ITEM (N) NOTE	ITEM	LENGTH		
120 WHT	A36	3	N2	J13	CC	I21 N3	9	36 IN	DATA OUT CH 12	SWITCH
121	A37	1	I13N1N6	J7	C	I13119N3N6	9	36 IN	GND	KY-68/LGM
122 BLU	A37	2	N1	J7	A	I19 N3	9	36 IN	WLTX-N CH 7	KY-68/LGM
123 WHT	A37	3	N1	J7	B	I19 N3	9	36 IN	WLTX-P CH 7	KY-68/LGM
124 BLU	A37	4	N1	J11	h	I21 N3	9	36 IN	DATA IN CH 7	KY-68/LGM
125 WHT	A37	5	N1	J11	w	I21 N3	9	36 IN	DATA IN CH 7	KY-68/LGM
126	A37	6	I13N1N6	J11II x	I13121N7N6	9	36 IN	GND	KY-68/LGM	
127	A38	1	I13N1N6	J7	F	I13119N3N6	9	36 IN	GND	KY-68/LGM
128 BLU	A38	2	N1	J7	D	I19 N3	9	36 IN	WLRX-N CH 7	KY-68/LGM
129 WHT	A38	3	N1	J7	E	I19 N3	9	36 IN	WLRX-P CH 7	KY-68/LGM
130 BLU	A38	4	NI	J11	M	I21 N3	9	36 IN	DATA OUT CH 7	KY-68/LGM
131 WHT	A38	5	N1	J11	9	I21 N3	9	36 IN	DATA OUT CH 7	KY-68/LGM
132	A38	6	I13N1N6	J11	x	I13121N3N8N6	9	36 IN	GND	KY-68/LGM
133	A39	1	I13N1N6	J8	C	I13119N3N6	9	36 IN	GND	KY-68/LGM
134 BLU	A39	2	N1	J8	A	I19 N3	9	36 IN	WLTX-N CH 8	KY-68/LGM
135 WHT	A39	3	N1	J8	B	I19 N3	9	36 IN	WLTX-P CH 8	KY-68/LGM
136 BR LI	A39	4	N1	J11	f	I21 N3	9	36 IN	DATA IN CH 8	KY-68/LGM

THIS DOCUMENT HAS BEEN PURCHASED BY THE GOVERNMENT AND MAY BE REPRODUCED AND USED IN CONNECTION WITH ANY GOVERNMENT PROCUREMENT OR MAINTENANCE OPERATION	SIZE	FSCM NO.	DRAWING NO.		
	A	80063	A3093172		
		SCALE	NONE	LTR	D SHEET 24

A3093172

WIRING LIST, POINT-TO-POINT, BLACK PATCH PANEL, AN/TYQ-30 (Sheets 23 & 24 of 37)

WIRE NO. OR COLOR	FROM TERMINATION			TO TERMINATION			WIRE		FUNCTION	REMARKS
	REF DES	PIN	(I) ITEM (N) NOTE	REF DES	PIN	(I) ITEM (N) NOTE	ITEM	LENGTH		
137 WHT	A39	5	N1	J11	u	I21 N3	9	36 IN	DATA IN CH 8	KY-68/LGM
138	A39	6	I13N1N6	J11	v	I13I21N7N6	9	36 IN	GND	KY-68/LGM
139	A40	1	I13N1N6	J8	F	I13I19N3N6	9	36 IN	GND	KY-68/LGM
140 BLU	A40	2	N1	J8	D	I19 N3	9	36 IN	WLRX-N CH 8	KY-68/LGM
141 WHT	A40	3	N1	J8	E	I19 N3	9	36 IN	WLRX-P CH 8	KY-68/LGM
142 BLU	A40	4	N1	J11	c	I21 N3	9	36 IN	DATA OUT CH 8	KY-68/LGM
143 WHT	A40	5	N1	J11	d	I21 N3	9	36 IN	DATA OUT CH 8	KY-68/LGM
144	A40	6	I13N1N6	J11	v	I13I21N3N8N6	9	36 IN	GND	KY-68/LGM
145	A41	1	I13N1N6	J9	C	I13I19N3N6	9	36 IN	GND	KY-68/LGM
146 BLU	A41	2	N1	J9	A	I19 N3	9	36 IN	WLTX-N CH 9	KY-68/LGM
147 WHT	A41	3	N1	J9	B	I19 N3	9	36 IN	WLTX-P CH 9	KY-68/LGM
148 BLU	A41	4	N1	J12	W	I21 N3	9	36 IN	DATA IN CH 9	KY-68/LGM
149 WHT	A41	5	N1	J12	X	I21 N3	9	36 IN	DATA IN CH 9	KY-68/LGM
150	A41	6	I13N1N6	J12	p	I13I21N7N6	9	36 IN	GND	KY-68/LGM
151	A42	1	I13N1N6	J9	F	I13I19N3N6	9	36 IN	GND	KY-68/LGM
152 BLU	A42	2	N1	J9	D	I19 N3	9	36 IN	WLRX-N CH 9	KY-68/LGM
153 WHT	A42	3	N1	J9	E	I19 N3	9	36 IN	WLRX-P CH 9	KY-68/LGM

0359N-2	THIS DOCUMENT HAS BEEN PURCHASED BY THE GOVERNMENT AND MAY BE REPRODUCED AND USED IN CONNECTION WITH ANY GOVERNMENT PROCUREMENT OR MAINTENANCE OPERATION	SIZE	FSCM NO.	DRAWING NO.	
		A	80063	A3093172	
		SCALE	NONE	LTR	B SHEET 25

WIRE NO. OR COLOR	FROM TERMINATION			TO TERMINATION			WIRE		FUNCTION	REMARKS
	REF DES	PIN	(I) ITEM (N) NOTE	REF DES	PIN	(I) ITEM (N) NOTE	ITEM	LENGTH		
154 BLU	A42	4	N1	J12	B	I21 N3	9	36 IN	DATA OUT CH 9	KY-68/LGM
155 WHT	A42	5	N1	J12	C	I21 N3	9	36 IN	DATA OUT CH 9	KY-68/LGM
156	A42	6	I13N1N6	J12	p	I13I21N3N8N6	9	36 IN	GND	KY-68/LGM
157	A43	1	I13N1N6	J10	C	I13I19N3N6	9	36 IN	GND	KY-68/LGM
158 BLU	A43	2	N1	J10	A	I19 N3	9	36 IN	WLTX-N CH 10	KY-68/LGM
159 WHT	A43	3	N1	J10	B	I19 N3	9	36 IN	WLTX-P CH 10	KY-68/LGM
160 BLU	A43	4	N1	J12	AA	I21 N3	9	36 IN	DATA IN CH 10	KY-68/LGM
161 WHT	A43	5	N1	J12	BB	I21 N3	9	36 IN	DATA IN CH 10	KY-68/LGM
162	A43	6	I13N1N6	J12	GG	I13I21N7N6	9	36 IN	GND	KY-68/LGM
163	A44	1	I13N1N6	J10	F	I13I19N3N6	9	36 IN	GND	KY-68/LGM
164 BLU	A44	2	N1	J10	D	I19 N3	9	36 IN	WLRX-N CH 10	KY-68/LGM
165 WHT	A44	3	N1	J10	E	I19 N3	9	36 IN	WLRX-P CH 10	KY-68/LGM
166 BLU	A44	4	N1	J12	q	I21 N3	9	36 IN	DATA OUT CH 10	KY-68/LGM
167 WHT	A44	5	N1	J12	z	I21 N3	9	36 IN	DATA OUT CH 10	KY-68/LGM
168	A44	6	I13N1N6	J12	GG	I13I21N3N8N6	9	36 IN	GND	KY-68/LGM
169	A45	1	I13N2N6	J12	x	I13I21N7N6	9	36 IN	GND	KY-68/LGM
170 BLU	A45	2	N2	J12	h	I21 N3	9	36 IN	DATA IN CH 15	KY-68/LGM

	THIS DOCUMENT HAS BEEN PURCHASED BY THE GOVERNMENT AND MAY BE REPRODUCED AND USED IN CONNECTION WITH ANY GOVERNMENT PROCUREMENT OR MAINTENANCE OPERATION	SIZE	FSCM NO.	DRAWING NO.	
		A	80063	A3093172	
		SCALE	NONE	LTR	D SHEET 26

A3093172

WIRING LIST, POINT-TO-POINT, BLACK PATCH PANEL, AN/TYQ-30
(Sheets 25 & 26 of 37)

WIRE NO. OR COLOR	FROM TERMINATION			TO TERMINATION			WIRE		FUNCTION	REMARKS
	REF DES	PIN	(I) ITEM (N) NOTE	REF DES	PIN	(I) ITEM (N) NOTE	ITEM	LENGTH		
171 WHT	A45	3	N2	J12	w	I21 N3	9	36 IN	DATA IN CH 15	KY-68/LGM
172	A46	1	I13 N2N6	J12	x	I13I21N3N8N6	9	36 IN	GND	KY-68/LGM
173 BLU	A46	2	N2	J12	M	I21 N3	9	36 IN	DATA OUT CH 15	KY-68/LGM
174 WHT	A46	3	N2	J12	g	I21 N3	9	36 IN	DATA OUT CH 15	KY-68/LGM
175	A47	1	I13 N2N6	J12	v	I13I21N7N6	9	36 IN	GND	KY-68/LGM
176 BLU	A47	2	N2	J12	f	I21 N3	9	36 IN	DATA IN CH 16	KY-68/LGM
177 WHT	A47	3	N2	J12	u	I21 N3	9	36 IN	DATA IN CH 16	KY-68/LGM
178	A48	1	I13 N2N6	J12	v	I13I21N3N8N6	9	36 IN	GND	KY-68/LGM
179 BLU	A48	2	N2	J12	c	I21 N3	9	36 IN	DATA OUT CH 16	KY-68/LGM
180 WHT	A48	3	N2	J12	d	I21 N3	9	36 IN	DATA OUT CH 16	KY-68/LGM
181 BLU	A49	2	N1	J29	A	I21 N3	9	36 IN	DATA IN CH 1	OPS
182 WHT	A49	3	N1	J29	B	I21 N3	9	36 IN	DATA IN CH 1	OPS
183 BLU	A49	4	N1	J12	Z	I21 N3	9	36 IN	DATA IN CH 11	LGM
184 WHT	A49	5	N1	J12	r	I21 N3	9	36 IN	DATA IN CH 11	LGM
185	A49	6	I13 N1N6	J12	CC	I13I21N7N6	9	36 IN	GND	LGM
186 BLU	A50	2	N1	J29	C	I21 N3	9	36 IN	DATA OUT CH 1	OPS
187 WHT	A50	3	N1	J29	D	I21 N3	9	36 IN	DATA OUT CH 1	OPS

0359N-2	THIS DOCUMENT HAS BEEN PURCHASED BY THE GOVERNMENT AND MAY BE REPRODUCED AND USED IN CONNECTION WITH ANY GOVERNMENT PROCUREMENT OR MAINTENANCE OPERATION	SIZE	FSCM NO.	DRAWING NO.	
		A	80063	A3093172	
		SCALE	NONE	LTR	B SHEET 27

WIRE NO. OR COLOR	FROM TERMINATION			TO TERMINATION			WIRE		FUNCTION	REMARKS
	REF DES	PIN	(I) ITEM (N) NOTE	REF DES	PIN	(I) ITEM (N) NOTE	ITEM	LENGTH		
188 BLU	A50	4	N1	J12	D	I21 N3	9	36 IN	DATA OUT CH 11	LGM
189 WHT	A50	5	N1	J12	Y	I21 N3	9	36 IN	DATA OUT CH 11	LGM
190	A50	6	I13N1N6	J12	CC	I13I21N3N8N6	9	36 IN	GND	LGM
191 BLU	A51	2	N1	J29	E	I21 N3	9	36 IN	DATA IN CH 2	OPS
192 WHT	A51	3	N1	J29	F	I21 N3	9	36 IN	DATA IN CH 2	OPS
193 BLU	A51	4	N1	J12	i	I21 N3	9	36 IN	DATA IN CH 12	LGM
194 WHT	A51	5	N1	J12	j	I21 N3	9	36 IN	DATA IN CH 12	LGM
195	A51	6	I13N1N6	J12	y	I13I21N7N6	9	36 IN	GND	LGM
196 BLU	A52	2	N1	J29	G	I21 N3	9	36 IN	DATA OUT CH 2	OPS
197 WHT	A52	3	N1	J29	H	I21 N3	9	36 IN	DATA OUT CH 2	OPS
198 BLU	A52	4	N1	J12	N	I21 N3	9	36 IN	DATA OUT CH 12	LGM
199 WHT	A52	5	N1	J12	P	I21 N3	9	36 IN	DATA OUT CH 12	LGM
200	A52	6	I13N1N6	J12	y	I13I21N3N8N6	9	36 IN	GND	LGM
201 BLU	A53	2	N1	J29	J	I21 N3	9	36 IN	DATA IN CH 3	OPS
202 WHT	A53	3	N1	J29	K	I21 N3	9	36 IN	DATA IN CH 3	OPS
203 BLU	A53	4	N1	J12	EE	I21 N3	9	36 IN	DATA IN CH 13	LGM
204 WHI	A53	5	N1	J12	FF	I21 N3	9	36 IN	DATA IN CH 13	LGM

THIS DOCUMENT HAS BEEN PURCHASED BY THE GOVERNMENT AND MAY BE REPRODUCED AND USED IN CONNECTION WITH ANY GOVERNMENT PROCUREMENT OR MAINTENANCE OPERATION	SIZE	FSCM NO.	DRAWING NO.	
	A	80063	A3093172	
		SCALE	NONE	LTR D SHEET 28

A3093172

WIRING LIST, POINT-TO-POINT, BLACK PATCH PANEL, AN/TYQ-30 (Sheets 27 & 28 of 37)

WIRE NO. OR COLOR	FROM TERMINATION			TO TERMINATION			WIRE		FUNCTION	REMARKS
	REF DES	PIN	(I) ITEM (N) NOTE	REF DES	PIN	(I) ITEM (N) NOTE	ITEM	LENGTH		
205	A53	6	I13N1N6	J12	HH	I13I21N7N6	9	36 IN	GND	LGM
206 BLU	A54	2	N1	J29	L	I21 N3	9	36 IN	DATA OUT CH 3	OPS
207 WHT	A54	3	N1	J29	M	I21 N3	9	36 IN	DATA OUT CH 3	OPS
208 BLU	A54	4	N1	J12	s	I21 N3	9	36 IN	DATA OUT CH 13	LGM
209 WHT	A54	5	N1	J12	DD	I21 N3	9	36 IN	DATA OUT CH 13	LGM
210	A54	6	I13N1N6	J12	HH	I13I21N3N8N6	9	36 IN	GND	LGM
211 BLU	A55	2	N1	J29	N	I21 N3	9	36 IN	DATA IN CH 4	OPS
212 WHT	A55	3	N1	J29	P	I21 N3	9	36 IN	DATA IN CH 4	OPS
213 BLU	A55	4	N1	J12	a	I21 N3	9	36 IN	DATA IN CH 14	LGM
214 WHT	A55	5	N1	J12	b	I21 N3	9	36 IN	DATA IN CH 14	LGM
215	A55	6	I13N1N6	J12	t	I13I21N7N6	9	36 IN	GND	LGM
216 BLU	A56	2	N1	J29	R	I21 N3	9	36 IN	DATA OUT CH 4	OPS
217 WHT	A56	3	N1	J29	S	I21 N3	9	36 IN	DATA OUT CH 4	OPS
218 BLU	A56	4	N1	J12	E	I21 N3	9	36 IN	DATA OUT CH 14	LGM
219 WHT	A56	5	N1	J12	F	I21 N3	9	36 IN	DATA OUT CH 14	LGM
220	A56	6	I13N1N6	J12	t	I13I21N3N8N6	9	36 IN	GND	LGM
221 BLU	A57	2	N2	J29	T	I21 N3	9	36 IN	DATA IN CH 5	OPS

0359N-2	THIS DOCUMENT HAS BEEN PURCHASED BY THE GOVERNMENT AND MAY BE REPRODUCED AND USED IN CONNECTION WITH ANY GOVERNMENT PROCUREMENT OR MAINTENANCE OPERATION	SIZE	FSCM NO.	DRAWING NO.	
		A	80063	A3093172	
		SCALE	NONE	LTR	B SHEET 29

WIRE NO. OR COLOR	FROM TERMINATION			TO TERMINATION			WIRE		FUNCTION	REMARKS
	REF DES	PIN	(I) ITEM (N) NOTE	REF DES	PIN	(I) ITEM (N) NOTE	ITEM	LENGTH		
222 WHT	A57	3	N2	J29	U	I21 N3	9	36 IN	DATA IN CH 5	OPS
223 BLU	A58	2	N2	J29	V	I21 N3	9	36 IN	DATA OUT CH 5	OPS
224 WHT	A58	3	N2	J29	W	I21 N3	9	36 IN	DATA OUT CH 5	OPS
225 BLU	A59	2	N2	J29	X	I21 N3	9	36 IN	DATA IN CH 6	OPS
226 WHT	A59	3	N2	J29	Y	I21 N3	9	36 IN	DATA IN CH 6	OPS
227 BLU	A60	2	N2	J29	Z	I21 N3	9	36 IN	DATA OUT CH 6	OPS
228 WHT	A60	3	N2	J29	a	I21 N3	9	36 IN	DATA OUT CH 6	OPS
229 BLU	A61	2	N2	J29	b	I21 N3	9	36 IN	DATA IN CH 7	OPS
230 WHT	A61	3	N2	J29	c	I21 N3	9	36 IN	DATA IN CH 7	OPS
231 BLU	A62	2	N2	J29	d	I21 N3	9	36 IN	DATA OUT CH 7	OPS
232 WHT	A62	3	N2	J29	e	I21 N3	9	36 IN	DATA OUT CH 7	OPS
233 BLU	A63	2	N2	J29	f	I21 N3	9	36 IN	DATA IN CH 8	OPS
234 WHT	A63	3	N2	J29	g	I21 N3	9	36 IN	DATA IN CH 8	OPS
235 BLU	A64	2	N2	J29	h	I21 N3	9	36 IN	DATA OUT CH 8	OPS
236 WHT	A64	3	N2	J29	k	I21 N3	9	36 IN	DATA OUT CH 8	OPS
237 BLU	A65	2	N2	J29	m	I21 N3	9	36 IN	DATA IN CH 9	OPS
238 WHT	A65	3	N2	J29	n	I21 N3	9	36 IN	DATA IN CH 9	OPS

THIS DOCUMENT HAS BEEN PURCHASED BY THE GOVERNMENT AND MAY BE REPRODUCED AND USED IN CONNECTION WITH ANY GOVERNMENT PROCUREMENT OR MAINTENANCE OPERATION	SIZE	FSCM NO.	DRAWING NO.	
	A	80063	A3093172	
		SCALE	NONE	LTR D SHEET 30

A3093172

WIRING LIST, POINT-TO-POINT, BLACK PATCH PANEL, AN/TYQ-30 (Sheets 29 & 30 of 37)

WIRE NO. OR COLOR	FROM TERMINATION			TO TERMINATION			WIRE		FUNCTION	REMARKS
	REF DES	PIN	(I) ITEM (N) NOTE	REF DES	PIN	(I) ITEM (N) NOTE	ITEM	LENGTH		
239 BLU	A66	2	N2	J29	p	I21 N3	9	36 IN	DATA OUT CH 9	OPS
240 WHT	A66	3	N2	J29	q	I21 N3	9	36 IN	DATA OUT CH 9	OPS
241 BLU	A67	2	N2	J29	r	I21 N3	9	36 IN	DATA IN CH 10	OPS
242 WHT	A67	3	N2	J29	s	I21 N3	9	36 IN	DATA IN CH 10	OPS
243 BLU	A68	2	N2	J29	t	I21 N3	9	36 IN	DATA OUT CH 10	OPS
244 WHT	A68	3	N2	J29	u	I21 N3	9	36 IN	DATA OUT CH 10	OPS
245 BLU	A69	2	N2	J29	v	I21 N3	9	36 IN	DATA IN CH 11	OPS
246 WHT	A69	3	N2	J29	w	I21 N3	9	36 IN	DATA IN CH 11	OPS
247 BLU	A70	2	N2	J29	x	I21 N3	9	36 IN	DATA OUT CH 11	OPS
248 WHT	A70	3	N2	J29	y	I21 N3	9	36 IN	DATA OUT CH 11	OPS
249 BLU	A71	2	N2	J29	z	I21 N3	9	36 IN	DATA IN CH 12	OPS
250 WHT	A71	3	N2	J29	AA	I21 N3	9	36 IN	DATA IN CH 12	OPS
251 BLU	A72	2	N2	J29	BB	I21 N3	9	36 IN	DATA OUT CH 12	OPS
252 WHT	A72	3	N2	J29	CC	I21 N3	9	36 IN	DATA OUT CH 12	OPS
253	W1P1	2	I1 N11	J14	A	I20 N3	7	36 IN	DATA IN LGM	LGM/GM
254	W1P1	3	I1 N11	J14	B	I20 N3	7	36 IN	DATA IN LGM	LGM/GM
255	W1P1	1	I1 N11	J14	M	I20N3N612414	7	36 IN	GND	LGM/GM

0359N-2	THIS DOCUMENT HAS BEEN PURCHASED BY THE GOVERNMENT AND MAY BE REPRODUCED AND USED IN CONNECTION WITH ANY GOVERNMENT PROCUREMENT OR MAINTENANCE OPERATION	SIZE	FSCM NO.	DRAWING NO.	
		A	80063	A3093172	
		SCALE	NONE	LTR	B SHEET 31

WIRE NO. OR COLOR	FROM TERMINATION			TO TERMINATION			WIRE		FUNCTION	REMARKS
	REF DES	PIN	(I) ITEM (N) NOTE	REF DES	PIN	(I) ITEM (N) NOTE	ITEM	LENGTH		
256	W1P2	2	I1 N11	J14	C	I20 N3	7	36 IN	TIM IN LGM	LGM/GM
257	W1P2	3	I1 N11	J14	D	I20 N3	7	36 IN	TIM IN LGM	LGM/GM
258	W1P2	1	I1 N11	J14	N	I20N3N612414	7	36 IN	GND	LGM/GM
259	W1P3	2	I1 N11	J14	E	I20N3	7	36 IN	DATA OUT LGM	LGM/GM
260	W1P3	3	I1 N11	J14	F	I20N3	7	36 IN	DATAOUTLGM	LGM/GM
261	W1P3	1	I1 N11	J14	P	I20N3N612414	7	36 IN	GND	LGM/GM
262	W1P4	2	I1 N11	J14	G	I20 N3	7	36 IN	TIM OUT LGM	LGM/GM
263	W1P4	3	I1 N11	J14	H	I20 N3	7	36 IN	TIM OUT LGM	LGM/GM
264	W1P4	1	I1 N11	J14	R	I20N3N612414	7	36 IN	GND	LGM/GM
265	W2P1	2	I1 N11	J15	E	I20 N3	7	36 IN	DATA OUT GM	LGM/GM
266	W2P1	3	I1 N11	J15	F	I20 N3	7	36 IN	DATA OUT GM	LGM/GM
267	W2P1	1	I1 N11	J15	P	I20N3N612414	7	36 IN	GND	LGM/GM
268	W2P2	2	I1 N11	J15	G	I20 N3	7	36 IN	TIM OUTGM	LGM/GM
269	W2P2	3	I1 N11	J15	H	I20 N3	7	36 IN	TIM OUT GM	LGM/GM
270	W2P2	1	I1 N11	J15	R	I20N3N612414	7	36 IN	GND	LGM/GM
271	W2P3	2	I1 N11	J15	A	I20 N3	7	36 IN	DATA IN GM	LGM/GM
272	W2P3	3	I1 N11	J15	B	I20 N3	7	36 IN	DATA IN GM	LGM/GM

THIS DOCUMENT HAS BEEN PURCHASED BY THE GOVERNMENT AND MAY BE REPRODUCED AND USED IN CONNECTION WITH ANY GOVERNMENT PROCUREMENT OR MAINTENANCE OPERATION	SIZE	FSCM NO.	DRAWING NO.	
	A	80063	A3093172	
		SCALE	NONE	LTR D SHEET 32

A3093172

WIRING LIST, POINT-TO-POINT, BLACK PATCH PANEL, AN/TYVQ-30 (Sheets 31 & 32 of 37)

WIRE NO. OR COLOR	FROM TERMINATION			TO TERMINATION			WIRE		FUNCTION	REMARKS
	REF DES	PIN	(I) ITEM (N) NOTE	REF DES	PIN	(I) ITEM (N) NOTE	ITEM	LENGTH		
273	W2P3	1	I1 N11	J15	M	I20 N3N612414 7		36 IN	GND	LGM/GM
274	W2P4	2	I1 N11	J15	C	I20 N3	7	36 IN	TIM IN GM	LGM/GM
275	W2P4	3	I1 N11	J15	D	I20 N3	7	36 IN	TIM IN GM	LGM/GM
276	W2P4	1	I1 N11	J15	N	I20 N3N612414 7		36 IN	GND	LGM/GM
277	W3P1	2	I1 N11	J16	E	I20 N3	7	36 IN	DATAOUTGM	LGM/GM
278	W3P1	3	I1 N11	J16	F	I20 N3	7	36 IN	DATA OUTGM	LGM/GM
279	W3P1	1	I1 N11	J16	P	I20 N3N612414 7		36 IN	GND	LGM/GM
280	W3P2	2	I1 N11	J16	G	I20 N3	7	36 IN	TIM OUTGM	LGM/GM
281	W3P2	3	I1 N11	J16	H	I20 N3	7	36 IN	TIM OUT GM	LGM/GM
282	W3P2	1	I1 N11	J16	R	I20 N3N612414 7		36 IN	GND	LGM/GM
283	W3P3	2	I1 N11	J16	A	I20 N3	7	36 IN	DATA IN GM	LGM/GM
284	W3P3	3	I1 N11	J16	B	I20 N3	7	36 IN	DATA IN GM	LGM/GM
285	W3P3	1	I1 N11	J16	M	I20 N3N612414 7		36 IN	GND	LGM/GM
286	W3P4	2	I1 N11	J16	C	I20 N3	7	36 IN	TIM IN GM	LGM/GM
287	W3P4	3	I1 N11	J16	D	I20 N3	7	36 IN	TIM IN GM	LGM/GM
288	W3P4	1	I1 N11	J16	N	I20 N3N612414 7		36 IN	GND	LGM/GM
289	A73	J1	N10	WI	P1					LGM/GM

0359N-2	THIS DOCUMENT HAS BEEN PURCHASED BY THE GOVERNMENT AND MAY BE REPRODUCED AND USED IN CONNECTION WITH ANY GOVERNMENT PROCUREMENT OR MAINTENANCE OPERATION	SIZE	FSCM NO.	DRAWING NO.	
		A	80063	A3093172	
		SCALE	NONE	LTR	B SHEET 33

WIRE NO. OR COLOR	FROM TERMINATION			TO TERMINATION			WIRE		FUNCTION	REMARKS
	REF DES	PIN	(I) ITEM (N) NOTE	REF DES	PIN	(I) ITEM (N) NOTE	ITEM	LENGTH		
290	A73	J2	N10	W2	P1					LGM/GM
291	A74	J1	N10	W1	P2					LGM/GM
292	A74	J2	N10	W2	P2					LGM/GM
293	A75	J1	N10	W1	P3					LGM/GM
294	A75	J2	N10	W2	P3					LGM/GM
295	A76	J1	N10	W1	P4					LGM/GM
296	A76	J2	N10	W2	P4					LGM/GM
297	A77	J1	N10	W3	P1					LGM/GM
298	A77	J2	N10	W3	P2					LGM/GM
299	A78	J1	N10	W3	P3					LGM/GM
300	A78	J2	N10	W3	P4					LGM/GM
301	W4P1	1	I9N12N17	J19	1	I2N12N17	6	36 IN	GND	GM/ROA
302	W4P1	2	I9N12N17	J19	2	I2N12N17	6	36 IN	LINE DATA IN 1	GM/ROA
303	W5P1	1	I23N12N16	J23	C	I12117N15	8	36 IN	GND	GM/ROA
304	W5P1	2	I23N12N16	J23	C	I12117N15	8	36 IN	LINE DATA IN 1	GM/ROA
305	W6P1	1	I9N12N17	J20	1	I3N12N17	6	36 IN	GND	GM/ROA
306	W6P1	2	I9N12N17	J20	2	I3N12N17	6	36 IN	LINE DATA OUT 1	GM/ROA

THIS DOCUMENT HAS BEEN PURCHASED BY THE GOVERNMENT AND MAY BE REPRODUCED AND USED IN CONNECTION WITH ANY GOVERNMENT PROCUREMENT OR MAINTENANCE OPERATION	SIZE	FSCM NO.	DRAWING NO.	
	A	80063	A3093172	
		SCALE	NONE	LTR D SHEET 34

WIRING LIST, POINT-TO-POINT, BLACK PATCH PANEL, AN/TYQ-30 (Sheets 33 & 34 of 37)

WIRE NO. OR COLOR	FROM TERMINATION			TO TERMINATION			WIRE		FUNCTION	REMARKS
	REF DES	PIN	(I) ITEM (N) NOTE	REF DES	PIN	(I) ITEM (N) NOTE	ITEM	LENGTH		
307	W5P2	1	I23N12N16	J23	G	I12I17N15	8	36 IN	GND	GM/ROA
308	W5P2	2	I23N12N16	J23	G	I12I17N15	8	36 IN	LINE DATA OUT 1	GM/ROA
309	W7P1	1	I9N12N17	J21	1	I2N12N17	6	36 IN	GND	GM/ROA
310	W7P1	2	I9N12N17	J21	2	I2N12N17	6	36 IN	LINE DATA IN 2	GM/ROA
311	W8P1	1	I23N12N16	J24	C	I12I17N15	8	36 IN	GND	GM/ROA
312	W8P1	2	I23N12N16	J24	C	I12I17N15	8	36 IN	LINE DATA IN 2	GM/ROA
313	W9P1	1	I9N12N17	J22	1	I3N12N17	6	36 IN	GND	GM/ROA
314	W9P1	2	I9N12N17	J22	2	I3N12N17	6	36 IN	LINE DATA OUT2	GM/ROA
315	W8P2	1	I23N12N16	J24	G	I12I17N15	8	36 IN	GND	GM/ROA
316	W8P2	2	I23N12N16	J24	G	I12I17N15	8	36 IN	LINE DATA OUT 2	GM/ROA
317	W10P1	1	I23N12N16	J25	A	I12I16N15	8	36 IN	GND	GM/SEP
318	W10P1	2	I23N12N16	J25	A	I12I16N15	8	36 IN	LINE DATA IN 1	GM/SEP
319	W10P2	1	I23N12N16	J25	B	I12I16N15	8	36 IN	GND	GM/SEP
320	W10P2	2	I23N12N16	J25	B	I12I16N15	8	36 IN	LINE DATA OUT 1	GM/SEP
321	W11P1	1	I23N12N16	J26	A	I12I16N15	8	36 IN	GND	GM/SEP
322	W11P1	2	I23N12N16	J26	A	I12I16N15	8	36 IN	LINE DATA IN 2	GM/SEP
323	W11P2	1	I23N12N16	J26	B	I12I16N15	8	36 IN	GND	GM/SEP

0359N-2	THIS DOCUMENT HAS BEEN PURCHASED BY THE GOVERNMENT AND MAY BE REPRODUCED AND USED IN CONNECTION WITH ANY GOVERNMENT PROCUREMENT OR MAINTENANCE OPERATION	SIZE	FSCM NO.	DRAWING NO.	
		A	80063	A3093172	
		SCALE	NONE	LTR	B SHEET 35

WIRE NO. OR COLOR	FROM TERMINATION			TO TERMINATION			WIRE		FUNCTION	REMARKS
	REF DES	PIN	(I) ITEM (N) NOTE	REF DES	PIN	(I) ITEM (N) NOTE	ITEM	LENGTH		
324	W11P2	2	I23N12N16	J26	B	I12I16N15	8	36 IN	LINE DATA OUT2	GM/SEP
325	A79	J1	N10	W4	P1					GM/ROA
326	A79	J2	N10	W5	P2					GM/ROA
327	A80	J1	N10	W6	P1					GM/ROA
328	A80	J2	N10	W5	P2					GM/ROA
329	A81	J1	N10	W7	P1					GM/ROA
330	A81	J2	N10	W8	P2					GM/ROA
331	A82	J1	N10	W9	P1					GM/ROA
332	A82	J2	N10	W8	P2					GM/ROA
333	A83	J1	N10	W10	P1					GM/ROA
334	A83	J2	N10	W10	P2					GM/VEP
335	A84	J1	N10	W11	P1					GM/VEP
336	A84	J2	N10	W11	P2					GMNEP
337	J17	A	I18 N4	J23	D	I17N4111	4	6 IN	XMTR TRAFFIC FAULT	GM/ROA
338	J17	B	I18 N4	J23	F	I17N4111	4	6 IN	OPTIC FAULT	GM/ROA
339	J17	C	I18 N4	J23	E	I17N4111	4	6 IN	RCV TRAFFIC FAULT	GM/ROA
340	117	D	I18 N4	J23	H	I17N4111	4	6 IN	+5	GM/ROA

THIS DOCUMENT HAS BEEN PURCHASED BY THE GOVERNMENT AND MAY BE REPRODUCED AND USED IN CONNECTION WITH ANY GOVERNMENT PROCUREMENT OR MAINTENANCE OPERATION	SIZE	FSCM NO.	DRAWING NO.	
	A	80063	A3093172	
		SCALE	NONE	LTR D SHEET 36

WIRING LIST, POINT-TO-POINT, BLACK PATCH PANEL, AN/TYQ-30 (Sheets 35 & 36 of 37)

WIRE NO. OR COLOR	FROM TERMINATION			TO TERMINATION			WIRE		FUNCTION	REMARKS
	REF DES	PIN	(I) ITEM (N) NOTE	REF DES	PIN	(I) ITEM (N) NOTE	ITEM	LENGTH		
341	J17	H	I18 N4	J23	A	I17N4111	4	6 IN	GND	GM/ROA
342	J18	A	I18 N4	J24	D	I17N4111	4	6 IN	XMTR TRAFFIC FAULT	GM/ROA
343	J18	B	I18 N4	J24	F	I17N4111	4	6 IN	OPTIC FAULT	GM/ROA
344	J18	C	I18 N4	J24	E	I17N4111	4	6 IN	RCV TRAFFIC FAULT	GM/ROA
345	J18-	D	I18 N4	J24	H	I17N4111	4	6 IN	+5	GM/ROA
346	J18	H	I18 N4	J24	A	I17N4111	4	6 IN	GND	GM/ROA
347	J27	A	I14	J28	A	I15	5	8 IN	POS	LS/147
348										
349										
350	J27	B	I14	J28	B	I15	5	8 IN	NEG	LS/147

0359N-2	THIS DOCUMENT HAS BEEN PURCHASED BY THE GOVERNMENT AND MAY BE REPRODUCED AND USED IN CONNECTION WITH ANY GOVERNMENT PROCUREMENT OR MAINTENANCE OPERATION	SIZE	FSCM NO.	DRAWING NO.	
		A	80063	A3093172	
		SCALE	NONE	LTR	B SHEET 37

WIRING LIST, POINT-TO-POINT, BLACK PATCH PANEL,
AN/TYQ-30
(Sheet 37 of 37)

A3093172

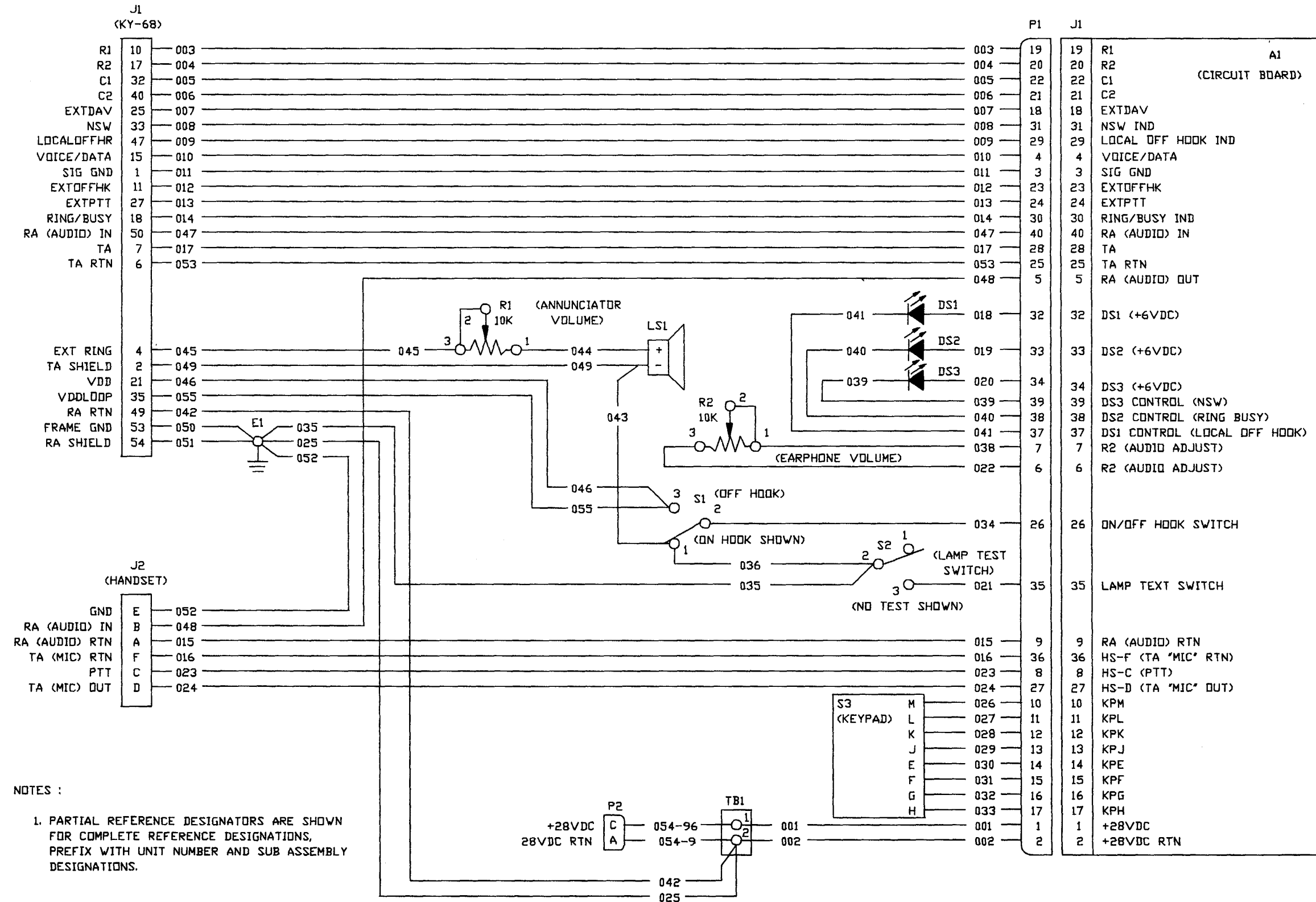

Schematic Diagram, Extension Phone

NOTE: DATA MARKED WITH AN ASTERISK PECULIAR TO A PRIOR MANUFACTURER. IT DOES NOT TAKE PRECEDENCE OVER ANY OTHER DATA ON THIS DRAWING, AND IS NOT CONTRACTUALLY BINDING ON EITHER THE CONTRACTOR OR THE GOVERNMENT.

<p>THIS DOCUMENT HAS BEEN PURCHASED BY THE GOVERNMENT AND MAY BE REPRODUCED AND USED IN CONNECTION WITH ANY GOVERNMENT PROCUREMENT OR MAINTENANCE OPERATION.</p>		<p>REVISIONS</p> <table border="1" style="width: 100%; border-collapse: collapse;"> <thead> <tr> <th style="width: 5%;">EFF</th> <th style="width: 5%;">LTR</th> <th style="width: 20%;">NO.</th> <th style="width: 55%;">DESCRIPTION</th> <th style="width: 10%;">DATE</th> <th style="width: 5%;">APPROVED</th> </tr> </thead> <tbody> <tr> <td>ALL</td> <td>A</td> <td></td> <td>INC ECN 92280, THESE SHEETS ADDED: 7, 8, AND 9</td> <td></td> <td></td> </tr> <tr> <td>ALL</td> <td>B</td> <td></td> <td>INC ECN 91547</td> <td>88-06-13</td> <td>LC</td> </tr> <tr> <td>ALL</td> <td>C</td> <td></td> <td>INC ECN 93356</td> <td>88-06-13</td> <td>LC</td> </tr> <tr> <td>ALL</td> <td>D</td> <td></td> <td>INC ECN 93425</td> <td>88-10-08</td> <td>DD</td> </tr> <tr> <td>ALL</td> <td>E</td> <td></td> <td>INC ECN 93429</td> <td>88-10-01</td> <td>DD</td> </tr> <tr> <td></td> <td>F</td> <td></td> <td>INC ECN 135552</td> <td>91-03-19</td> <td>PB 377</td> </tr> </tbody> </table>			EFF	LTR	NO.	DESCRIPTION	DATE	APPROVED	ALL	A		INC ECN 92280, THESE SHEETS ADDED: 7, 8, AND 9			ALL	B		INC ECN 91547	88-06-13	LC	ALL	C		INC ECN 93356	88-06-13	LC	ALL	D		INC ECN 93425	88-10-08	DD	ALL	E		INC ECN 93429	88-10-01	DD		F		INC ECN 135552	91-03-19	PB 377
EFF	LTR	NO.	DESCRIPTION	DATE	APPROVED																																									
ALL	A		INC ECN 92280, THESE SHEETS ADDED: 7, 8, AND 9																																											
ALL	B		INC ECN 91547	88-06-13	LC																																									
ALL	C		INC ECN 93356	88-06-13	LC																																									
ALL	D		INC ECN 93425	88-10-08	DD																																									
ALL	E		INC ECN 93429	88-10-01	DD																																									
	F		INC ECN 135552	91-03-19	PB 377																																									

REV	SHEET																			
REV STATUS OF SHEETS	REV SHEET	F	F	A	A	F	D	D	D	D										
<p>1. PREPARED IN ACCORDANCE WITH DOD-STD-100.</p> <p>2. UNLESS OTHERWISE SPECIFIED, DIMENSIONS ARE IN INCHES.</p>		ELECTROSPACE SYSTEMS, INC.		U.S. ARMY COMMUNICATIONS— ELECTRONIC COMMAND FORT MONMOUTH, NEW JERSEY 07703																
		DAAB07-86-C-J008		DRAWING TITLE																
		APVD	M. MARTIN	88-02-08	WIRING LIST, POINT-TO-POINT, EXTENSION PHONE															
		ENGR	D. PLEMONS	88-02-04																
		ENGR	C. PYBUS	88-02-03																
		CHECK	L. FETZER	88-02-05																
		DRAWN	L. CHATELAIN	88-02-03																
		REV																		
A3093175	DLA3093175	APVD			SIZE	FSCM NO.	DRAWING NO.													
NEXT ASSY	USED ON	DATE			A	80063	A3093177													
APPLICATION					SCALE	NONE	F	SHEET 1 OF 9												

NOTES:

1. REFERENCE SCHEMATIC DIAGRAM A3093176.
2. SOLDER PER MIL-STD-454, REQUIREMENT 5. HEAT SHRINK 1/2 INCH LENGTH OF ITEM 3 OVER SOLDER TERMINATIONS.
3. STRIP WIRE 0.125 INCHES. CRIMP CONTACTS (ITEM 2) WITH AMP INCORPORATED 90346-1 HANDTOOL. INSERT TERMINATED INTO FREE-HANGING CONNECTOR (P1) EXTRACTION TOOL IS AMP P/N 91156-1.
4. STRIP WIRE 0.125 INCHES. CRIMP CONTACTS (ITEM 4) WITH M22520/2-01 TOOL WITH M22520/2-09 TURRET PER MIL-C-22520. INSERT TERMINATED WIRE INTO CONNECTOR (J1) WITH M81969/14-01 INSERTION TOOL PER MIL-1-81969.
5. CRIMP RING LUG (ITEM 5) WITH MIL-C-22520/5-01 TOOLING WITH MIL-C-22520/5-100 DIE.
6. INSERT JASKSCREWS (ITEM 6) INTO EACH END OF CONNECTOR (P1). CONNECT P1 TO J1 OF CIRCUIT BOARD AFTER ALL WIRE TERMINATIONS ARE MADE.
7. UNLESS OTHERWISE SPECIFIED, WIRE LENGTH TOLERANCES ARE + I, -0 INCHES.
8. THIS NOTE INTENTIONALLY LEFT BLANK.
9. PLACE BACKSHELL OVER CABLE PRIOR TO INSERTING PINS. REFER TO FIGURE 1 FOR CABLE STRIP LENGTHS. CRIMP PINS WITH M22520/2-01 TOOL WITH M22520/2-10 TURRET. REF MIL-C-22520.
10. OVERALL LENGTH AS MEASURED FROM GROMMET TO END OF P2 SHALL BE 72 + 1 INCHES.
11. LONG LEAD OF LED INDICATORS IS THE POSITIVE LEAD.
12. TYPE APPROPRIATE "W" NUMBER ON TWO 11/2 INCH LENGTHS OF ITEM 13 FOR EACH WIRE. SHRINK OVER EACH END.

<p>THIS DOCUMENT HAS BEEN PURCHASED BY THE GOVERNMENT AND MAY BE REPRODUCED AND USED IN CONNECTION WITH ANY GOVERNMENT PROCUREMENT OR MAINTENANCE OPERATION</p>	SIZE	FSCM NO.	DRAWING NO.
	A	80063	A3093177
	SCALE	NONE	LTR F SHEET 2

WIRING LIST, POINT-TO-POINT, EXTENSION PHONE (Sheets 1 & 2 of 9)

A3093177

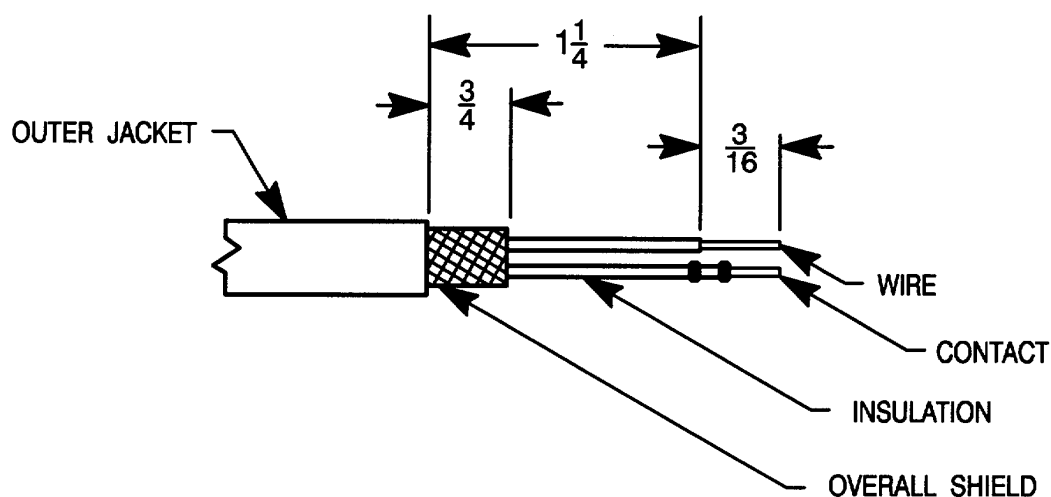

FIGURE 1. CABLE PREPARATION

THIS DOCUMENT HAS BEEN PURCHASED BY THE GOVERNMENT AND MAY BE REPRODUCED AND USED IN CONNECTION WITH ANY GOVERNMENT PROCUREMENT OR MAINTENANCE OPERATION	SIZE	FSCM NO.	DRAWING NO. A3093177	
	A	80063	A3093177	
	SCALE	NONE	LTR	A
			SHEET	3

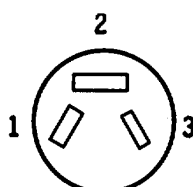

FIGURE 2. POTENTIOMETER PINOUT

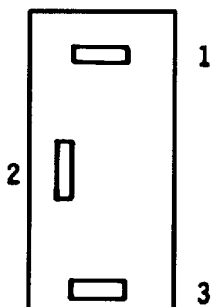

FIGURE 3. TOGGLE SWITCH PINOUT

THIS DOCUMENT HAS BEEN PURCHASED BY THE GOVERNMENT AND MAY BE REPRODUCED AND USED IN CONNECTION WITH ANY GOVERNMENT PROCUREMENT OR MAINTENANCE OPERATION	SIZE	FSCM NO.	DRAWING NO. A3093177	
	A	80063	SHEET 4	
	SCALE	NONE	LTR	A
			SHEET	4

QTY	ITEM	PART NO.	DESCRIPTION	SPEC/STD	FSCM NO.
1	1	M55302/113-16	CONNECTOR, PLUG (P1)	MIL-C-55302	81349
40	2	M55302/113-05	CONTACT, CRIMP	MIL-C-55302	81349
AR	3	M23053/5-103-9	SLEEVING, HEAT SHRINKABLE, WHITE	MIL-I-23053/5	81349
55	4	M39029/58-360	CONTACT	MIL-C-39029	81349
21	5	MS25036-102	TERMINAL LUG, RING, NO. 6, 22 AWG		96906
2	6	M55302/113-12	JACKSCREW, CONNECTOR	MIL-C-55302	81349
1	7	MS27467T9B98P	CONNECTOR, PLUG (P2)		96906
	8				
1	9	A3092983-1	BACKSHELL		80063
80	10	M27500-22TG2T14	WIRE, TWISTED PAIR, 22 AWG	(IN) MIL-C-27500	81349
2	11	MS51957-19	SCREW		96906
2	12	MS35338-135	WASHER, LOCK		96906
AR	13	M23053/5-102-9	HEAT SHRINK SLEEVING	(IN) MIL-I-23053/5	81349
15	E22-2	M16878/4BFE2	WIRE, 22 AWG, RED	(IN) MIL-W-16878/4	81349
124	E22-5	M16878/4BFE5	WIRE, 22 AWG, GREEN	(IN) MIL-N-16878/4	81349
782	E22-9	M16878/4BFE9	WIRE, 22 AWG, WHITE	(IN) MIL-W-16878/4	81349

THIS DOCUMENT HAS BEEN PURCHASED BY THE GOVERNMENT AND MAY BE REPRODUCED AND USED IN CONNECTION WITH ANY GOVERNMENT PROCUREMENT OR MAINTENANCE OPERATION	SIZE A	FSCM NO. 80063	DRAWING NO. A3093177	
	SCALE NONE	LTR F	SHEET 5	

WIRE NO. OR COLOR	FROM TERMINATION			TO TERMINATION			WIRE		FUNCTION	REMARKS
	REF DES	PIN	(I) ITEM (N) NOTE	REF DES	PIN	(I) ITEM (N) NOTE	ITEM	LENGTH		
001	TB1	1	I5 N5	P1	1	I2 N3	E22-2	15 IN	24 VDC	DC POWER IN
002	TB1	2	I5 N5	P1	2	I2 N3	E22-5	15 IN	DC COM	DC COMMON
003	J1	10	I4 N4	P1	19	I2 N3	E22-9	19 IN		EXT-R1
004	J1	17	I4 N4	P1	20	I2 N3	E22-9	19 IN		EXT-R2
005	J1	32	I4 N4	P1	22	I2 N3	E22-9	19 IN		EXT-C1
006	J1	40	I4 N4	P1	21	I2 N3	E22-9	19 IN		EXT-C2
007	J1	25	I4 N4	P1	18	I2 N3	E22-9	19 IN		EXT DAV
008	J1	33	I4 N4	P1	31	I2 N3	E22-9	19 IN		NSW
009	J1	47	I4 N4	P1	29	I2 N3	E22-9	19 IN		LOC OFF HK
010	J1	15	I4 N4	P1	4	I2 N3	E22-9	19 IN		VOICE/DATA
011	J1	1	I4 N4	P1	3	I2 N3	E22-9	19 IN		SIG GND
012	J1	11	I4 N4	P1	23	I2 N3	E22-9	19 IN		EXT OFF HK
013	J1	27	I4 N4	P1	24	I2 N3	E22-9	19 IN		EXT PTT
014	J1	18	I4 N4	P1	30	I2 N3	E22-9	19 IN		RING/BUSY
015	P1	9	I2 N3	J2	A	N2	E22-9	19 IN		RA RET
016	P1	36	I2 N3	J2	F	N2	E22-9	19 IN		TA RET
017	J1	7	I4 N4	P1	28	I2 N3	E22-9	19 IN		TA

THIS DOCUMENT HAS BEEN PURCHASED BY THE GOVERNMENT AND MAY BE REPRODUCED AND USED IN CONNECTION WITH ANY GOVERNMENT PROCUREMENT OR MAINTENANCE OPERATION	SIZE A	FSCM NO. 80063	DRAWING NO. A3093177	
	SCALE NONE	LTR D	SHEET 6	

WIRE NO. OR COLOR	FROM TERMINATION			TO TERMINATION			WIRE		FUNCTION	REMARKS
	REF DES	PIN	(I) ITEM (N) NOTE	REF DES	PIN	(I) ITEM (N) NOTE	ITEM	LENGTH		
018	DS1	+	N2 N12	P1	32	I2 N3	E22-9	19 IN		DS1 +6V
019	DS2	+	N2 N12	P1	33	I2 N3	E22-9	17 IN		DS2 +6V
020	DS3	+	N2 N12	P1	34	I2 N3	E22-9	16 IN		DS3 +6V
021	S2	3	I5	P1	35	I2 N3	E22-9	19 IN		LAMP TEST
022	R2	3	N2	P1	6	I2 N3	E22-9	19 IN		AUDIO ADJUST
023	J2	C	N2	P1	8	I2 N3	E22-9	19 IN		PTT
024	J2	D	N2	P1	27	I2 N3	E22-9	19 IN		TA
025	TB1	2	I5 N5	E1		I5 N5	E22-5	23 IN		GND
026	S3	M	N2	P1	10	I2 N3	E22-9	15 IN		KEYPAD INPUT
027	S3	L	N2	P1	11	I2 N3	E22-9	15 IN		KEYPAD
INPUT										
028	S3	K	N2	P1	12	I2 N3	E22-9	15 IN		KEYPAD
INPUT										
029	S3	J	N2	P1	13	I2 N3	E22-9	15 IN		KEYPAD
INPUT										
030	S3	E	N2	P1	14	I2 N3	E22-9	15 IN		KEYPAD
INPUT										
031	S3	F	N2	P1	15	I2 N3	E22-9	15 IN		KEYPAD
INPUT										
032	S3	G	N2	P1	16	I2 N3	E22-9	15 IN		KEYPAD
INPUT										
033	S3	H	N2	P1	17	I2 N3	E22-9	15 IN		KEYPAD
INPUT										
034	S1	2	I5	P1	26	I2 N3	E22-9	17 IN		ON/OFF HK
SW										

0446N

THIS DOCUMENT HAS BEEN PURCHASED BY THE GOVERNMENT AND MAY BE REPRODUCED AND USED IN CONNECTION WITH ANY GOVERNMENT PROCUREMENT OR MAINTENANCE OPERATION	SIZE	FSCM NO.	DRAWING NO.
	A	80063	A3093177
	SCALE	NONE	LTR D SHEET 7

WIRE NO. OR COLOR	FROM TERMINATION			TO TERMINATION			WIRE		FUNCTION	REMARKS
	REF DES	PIN	(I) ITEM (N) NOTE	REF DES	PIN	(I) ITEM (N) NOTE	ITEM	LENGTH		
035	S2	2	I5	E1		I5 N5	E22-5	23 IN		GND
036	S1	1	I5	S2	2	I5	E22-9	19 IN		GND
038	R2	1	N2	P1	7	I2 N3	E22-9	19 IN		AUDIO ADJUST
039	P1	39	I2 N3	DS3	-	N2	E22-9	19 IN		DS3 CNTL
040	P1	38	I2 N3	DS2		N2	E22-9	19 IN		DS2 CNTL
041	P1	37	I2 N3	DS1	-	N2	E22-9	19 IN		DS1 CNTL
042	J1	49	I4 N4	TB1	2	I5 N5	E22-5	23 IN		GND
043	S1	1	I5	LS1	-	I5 N5	E22-9	20 IN		GND
044	LS1	+	I5 N5	R1	1	N2	E22-9	10 IN		RING ADJUST
045	R1	3	N2	J1	4	I4 N4	E22-9	15 IN		EXT RING
046	J1	21	I4 N4	S1	3	I5	E22-9	19 IN		VDD/VDD LOOP
047	J1	50	I4 N4	P1	40	I2 N3	E22-9	20 IN		RA
048	P1	5	I2 N3	J2	B	N2	E22-9	19 IN		RA
049	J1	2	I4 N4	LS1	-	I5 N5	E22-9	15 IN		TA SHIELD
050	J1	53	I4 N4	E1		I5 N5	E22-5	15 IN		FRAME GND
051	J1	54	I4 N4	E1		I5 N5	E22-5	15 IN		RA SHIELD
052	J2	E	N2	E1		I5 N5	E22-5	10 IN		HANDSET SHIELD

THIS DOCUMENT HAS BEEN PURCHASED BY THE GOVERNMENT AND MAY BE REPRODUCED AND USED IN CONNECTION WITH ANY GOVERNMENT PROCUREMENT OR MAINTENANCE OPERATION	SIZE	FSCM NO.	DRAWING NO.
	A	80063	A3093177
	SCALE	NONE	LTR D SHEET 8

WIRE NO. OR COLOR	FROM TERMINATION			TO TERMINATION			WIRE		FUNCTION	REMARKS
	REF DES	PIN	(I) ITEM	REF DES	PIN	(I) ITEM	ITEM	LENGTH		
053	J1	6	14 N4	P1	25	12 N3	E22-9	20 IN		TA RTN
054-96	P2	C	N9 N11	TB1	1	15 N5 N10	10	72 IN		WHITE/BLUE
054-9	P2	A	N9 N11	TB1	2	15 N5 N10	10	72 IN		WHITE
055	J1	35	14 N4	S1	3	15	E22-9	19 IN		VDD/VDD LOOP
JUMPER-1	R1	2	N2	R1	3	N2	E22-9	4 IN		WIPER R1
JUMPER-2	R2	2	N2	R2	1	N2	E22-9	4 IN		WIPER R2

0446N	THIS DOCUMENT HAS BEEN PURCHASED BY THE GOVERNMENT AND MAY BE REPRODUCED AND USED IN CONNECTION WITH ANY GOVERNMENT PROCUREMENT OR MAINTENANCE OPERATION	SIZE	FSCM NO.	DRAWING NO.
		A	80063	A3093177
		SCALE	NONE	LTR D SHEET 9

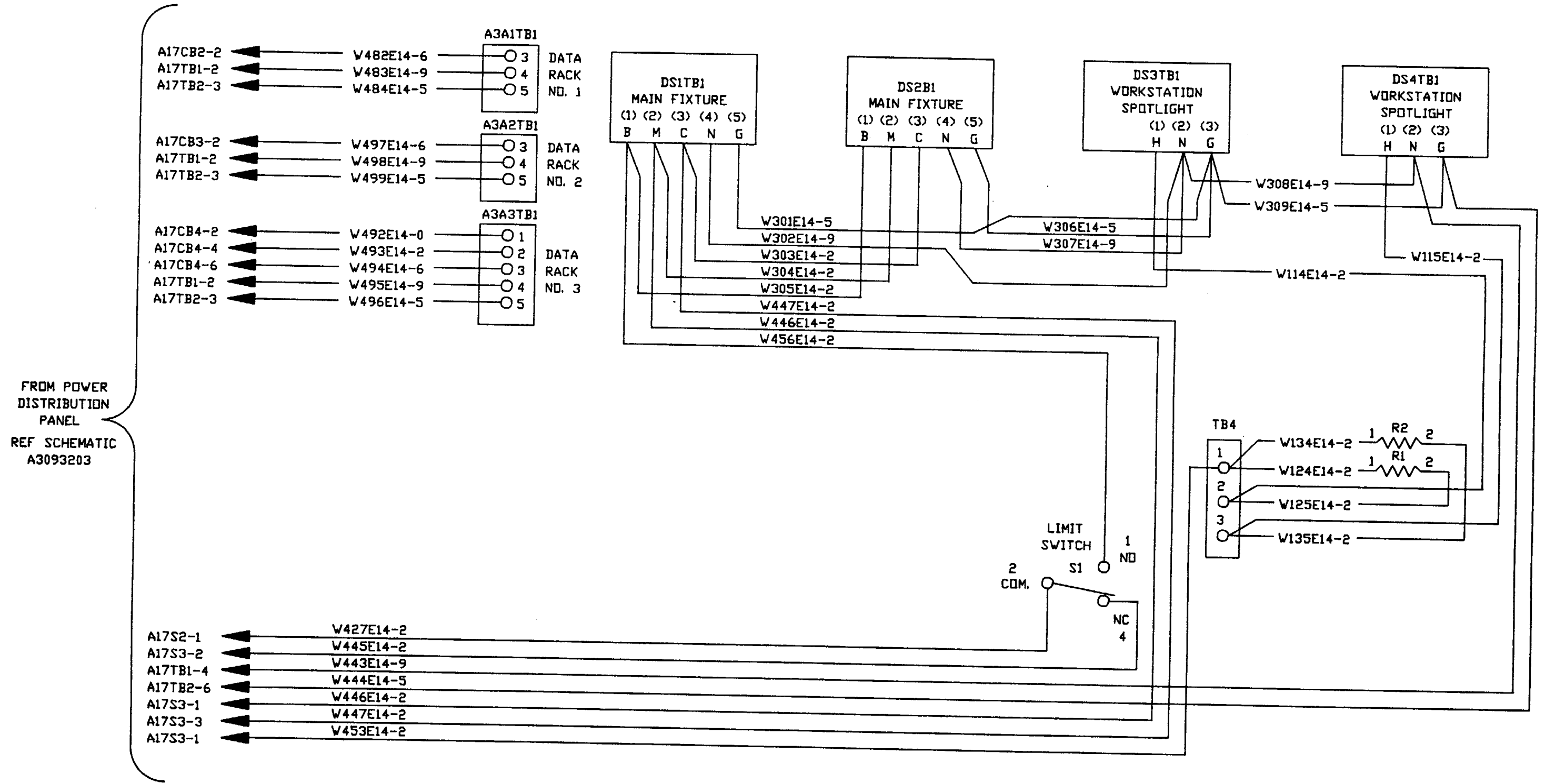

NOTES :

- PARTIAL REFERENCE DESIGNATIONS ARE SHOWN FOR COMPLETE REFERENCE DESIGNATION, PREFIX WITH UNIT NUMBER AND SUB ASSEMBLY DESIGNATION.

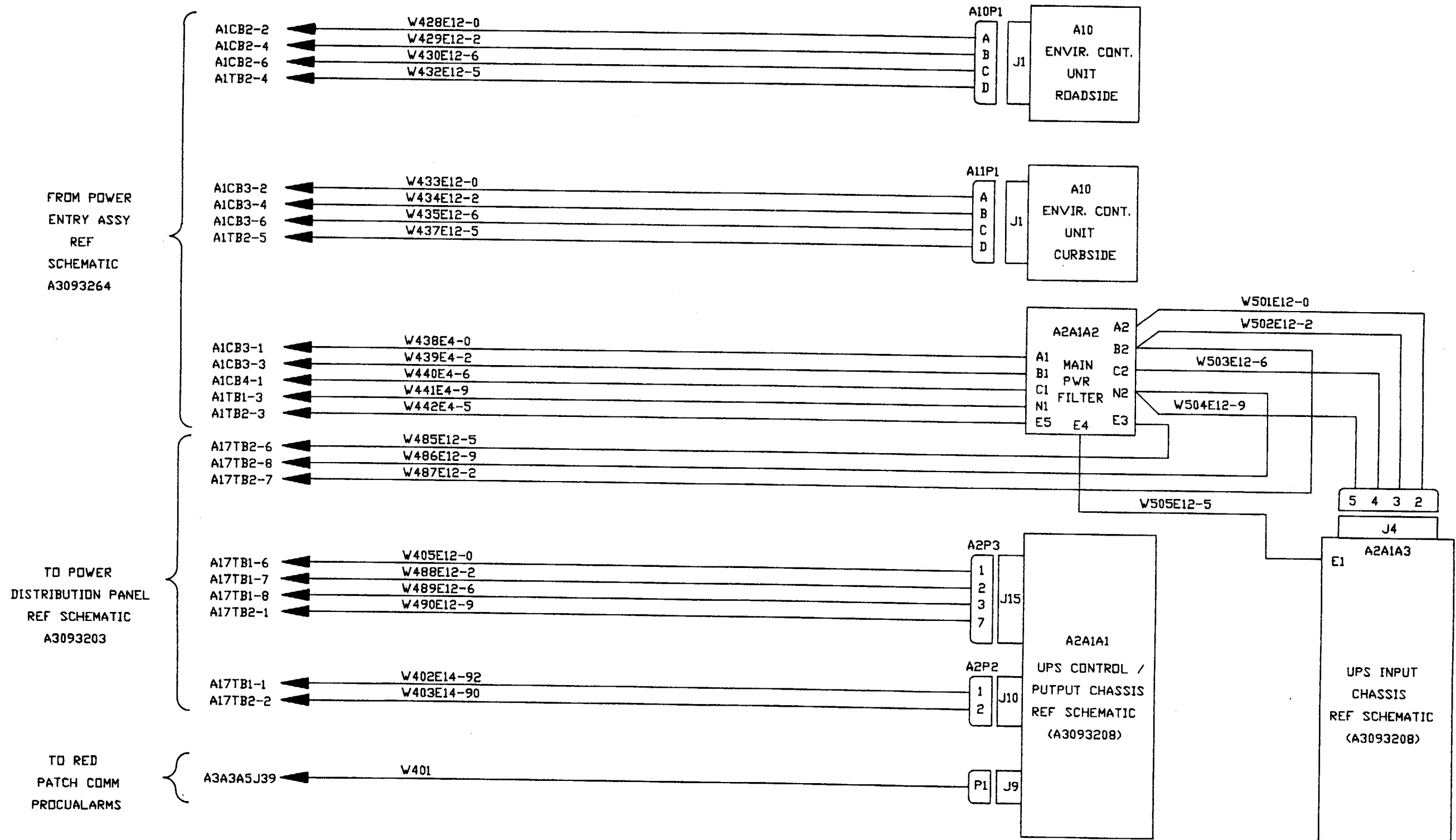

Schematic Diagram, Power Distribution - ADP Shelter (Sheet 2 of 4)

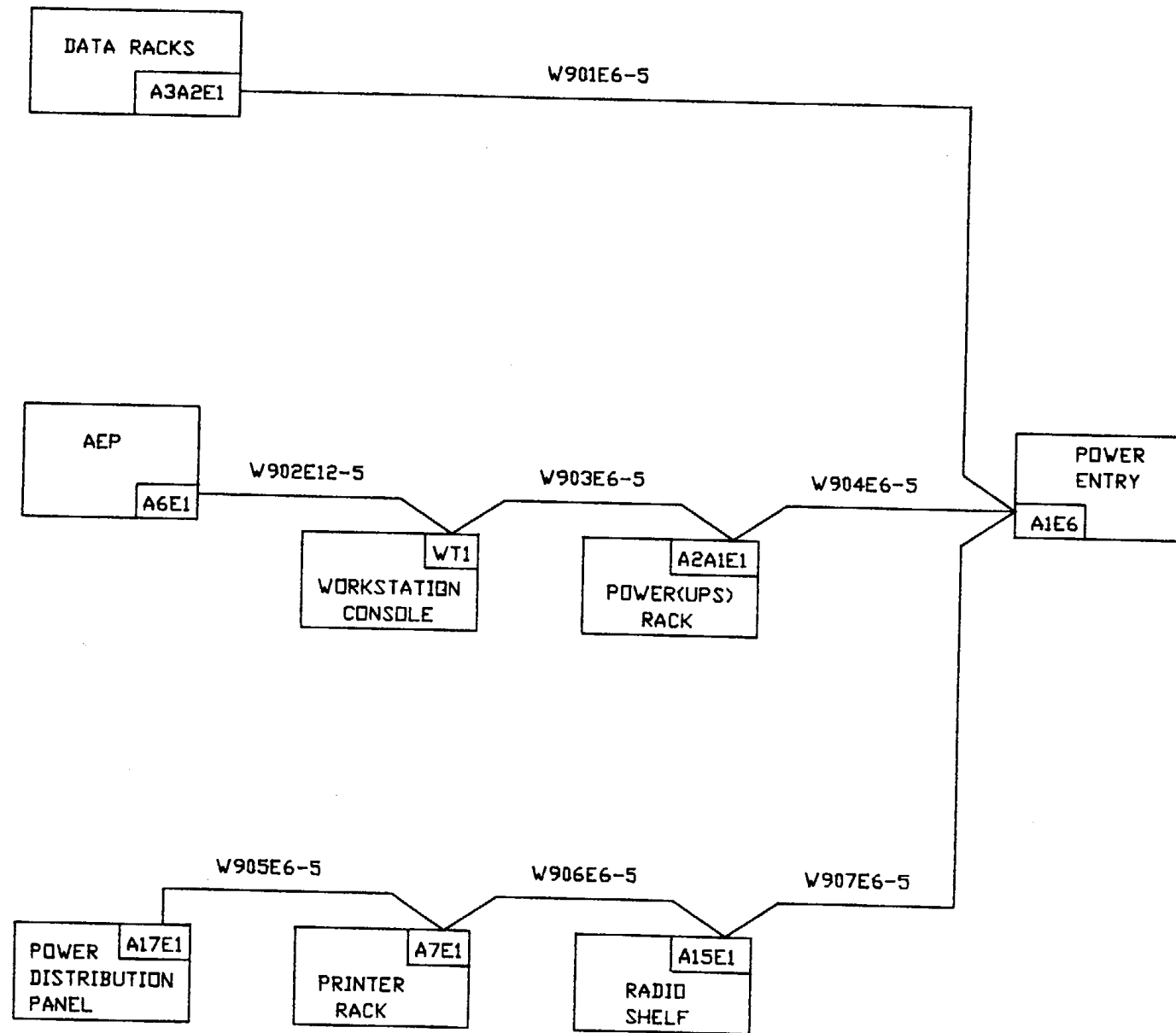

Schematic Diagram, Power Distribution - ADP Shelter (Sheet 3 of 4)

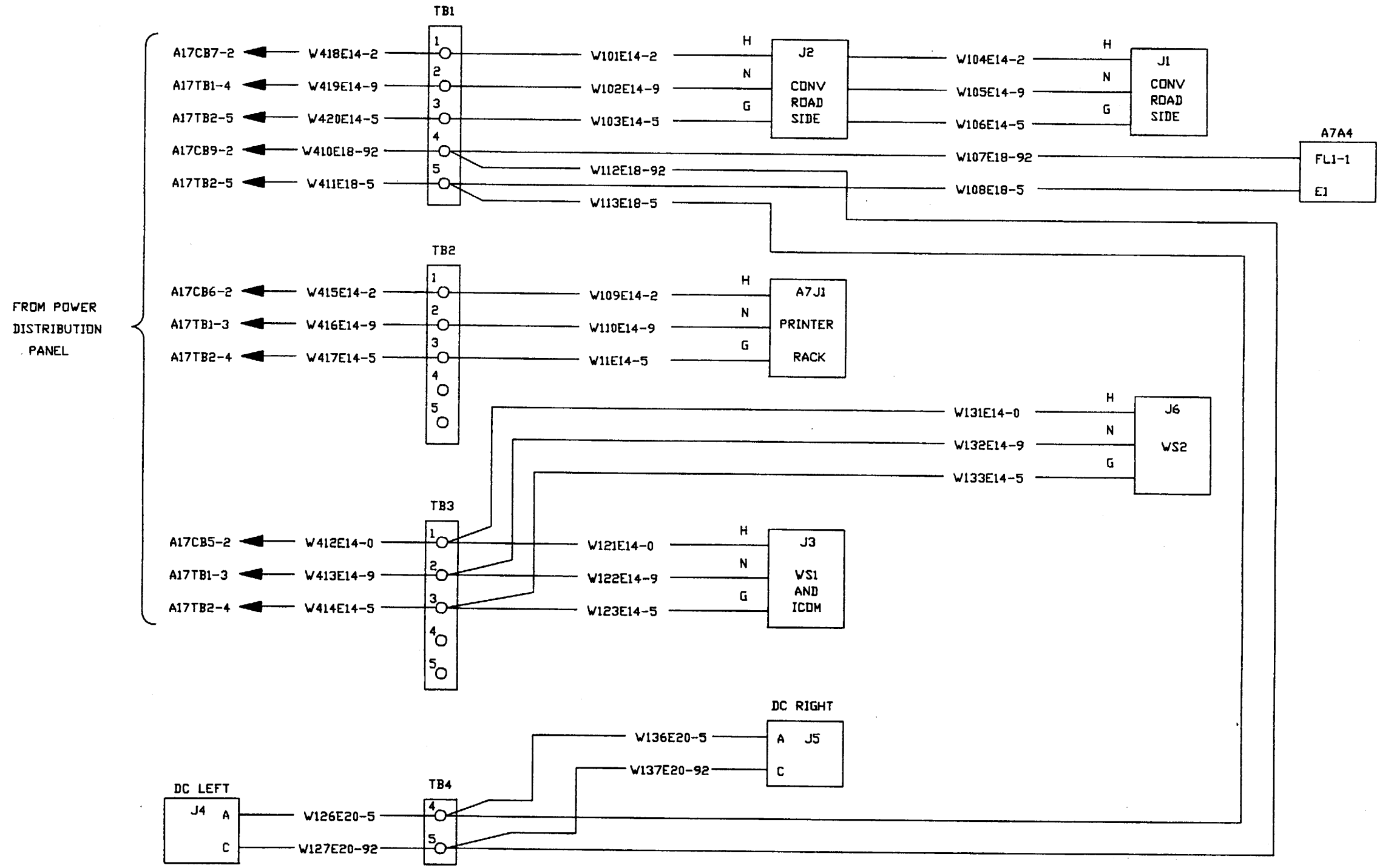

Schematic Diagram, Power Distribution - ADP Shelter (Sheet 4 of 4)

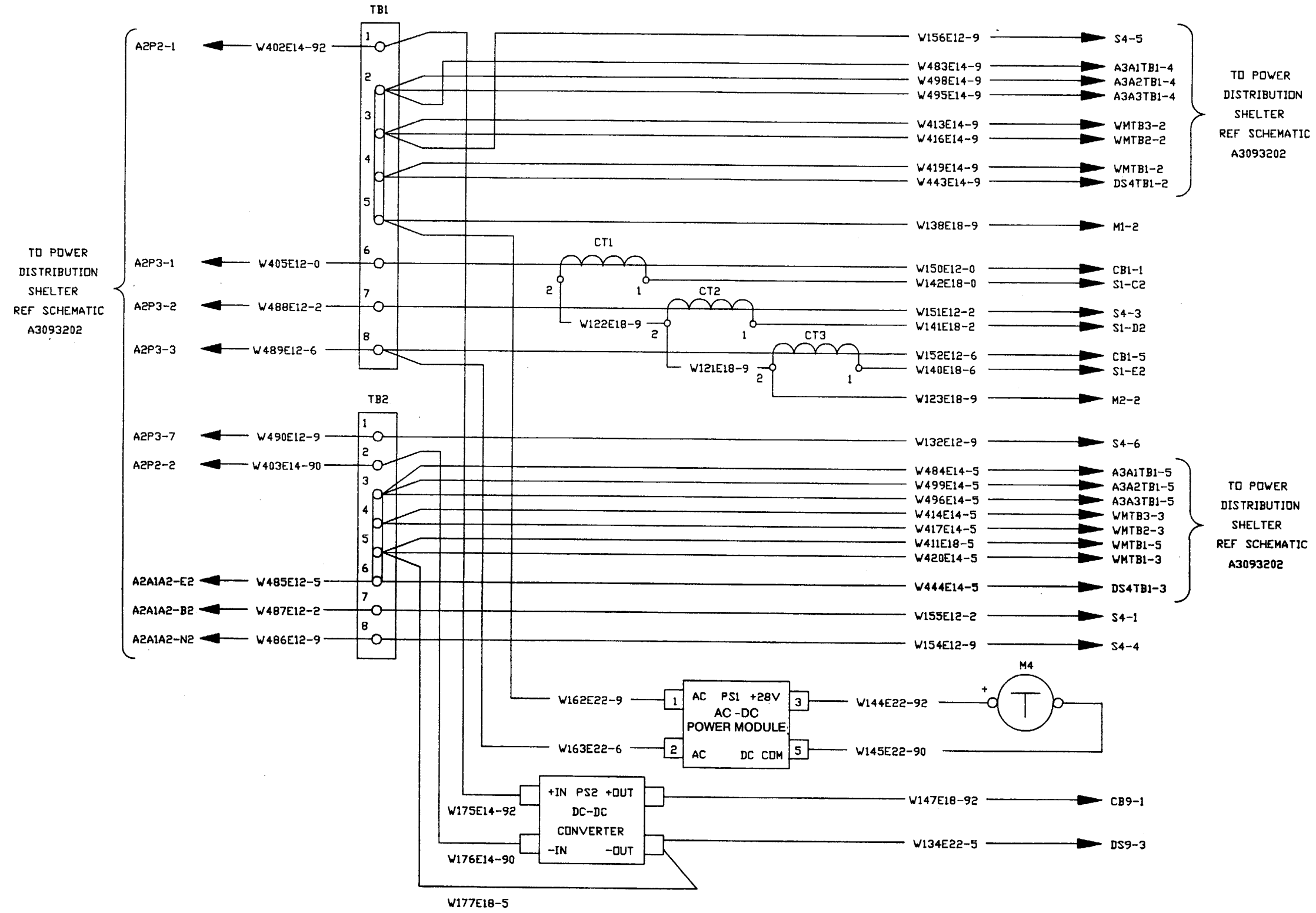

Schematic Diagram, Power Distribution Panel (Sheet 1 of 2)

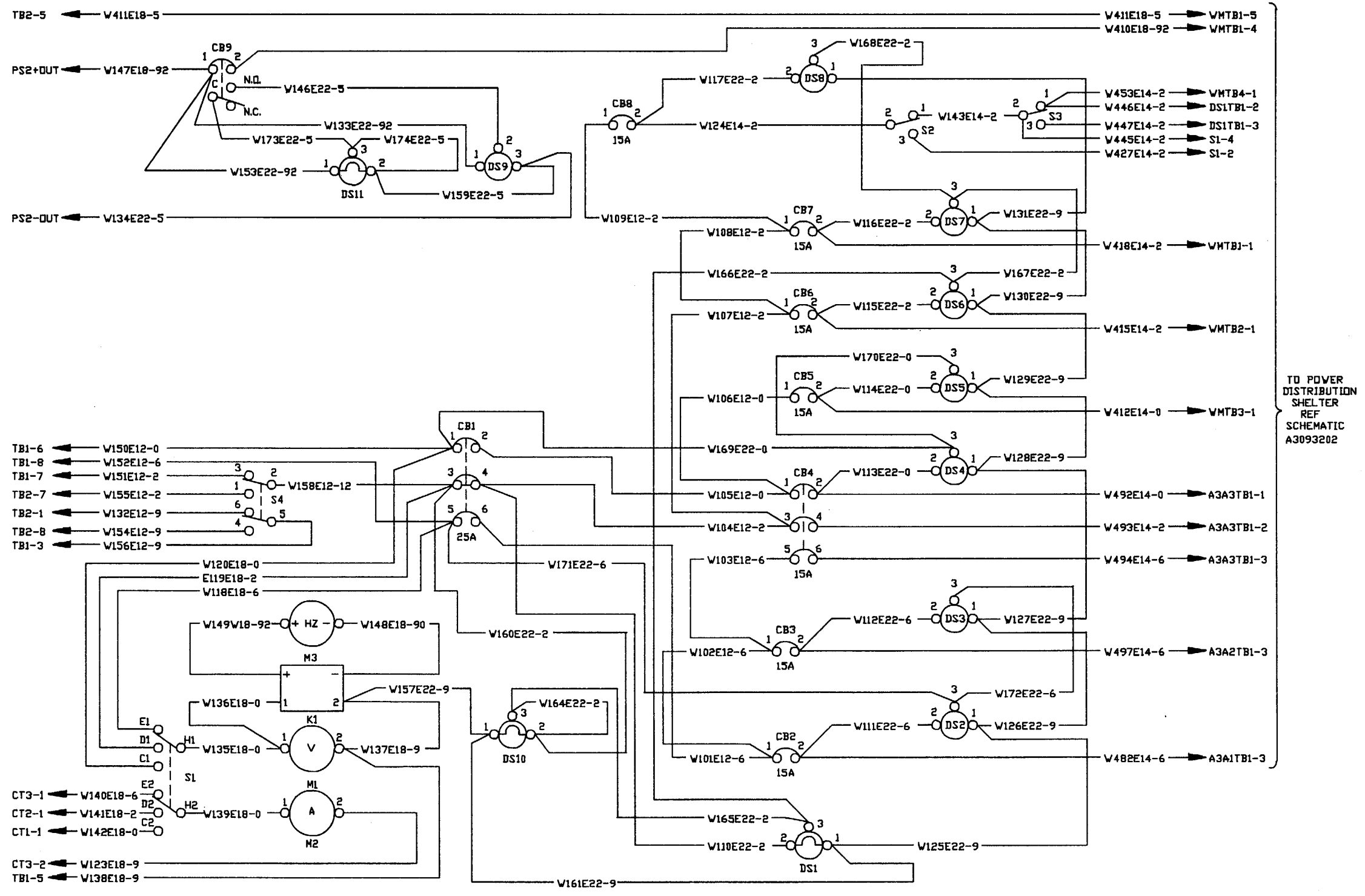

TO POWER DISTRIBUTION SHELTER REF SCHEMATIC A3093202

Schematic Diagram, Power Distribution Panel (Sheet 2 of 2)

NOTE: DATA MARKED WITH AN ASTERISK IS PECULIAR TO A PRIOR MANUFACTURER. IT DOES NOT TAKE PRECEDENCE OVER ANY OTHER DATA ON THIS DRAWING, AND IS NOT CONTRACTUALLY BINDING ON EITHER THE CONTRACTOR OR THE GOVERNMENT.

THIS DOCUMENT HAS BEEN PURCHASED BY THE GOVERNMENT AND MAY BE REPRODUCED AND USED IN CONNECTION WITH ANY GOVERNMENT PROCUREMENT OR MAINTENANCE OPERATION.	REVISIONS																														
	<table border="1" style="width: 100%; border-collapse: collapse;"> <thead> <tr> <th style="width: 5%;">EFF</th> <th style="width: 5%;">LTR</th> <th style="width: 10%;">NO.</th> <th style="width: 55%;">DESCRIPTION</th> <th style="width: 10%;">DATE</th> <th style="width: 15%;">APPROVED</th> </tr> </thead> <tbody> <tr> <td>ALL</td> <td>A</td> <td></td> <td>INC ECN 93273</td> <td>88-07-25</td> <td>LC CP TB</td> </tr> <tr> <td></td> <td>B</td> <td></td> <td>INC ECN 102118, EFF: 88-11-17</td> <td>88-12-06</td> <td>DD CP TB</td> </tr> <tr> <td></td> <td>C</td> <td></td> <td>INC ECN 102631, EFF: 01-26-89</td> <td>89-02-27</td> <td>DD TB</td> </tr> <tr> <td></td> <td>D</td> <td></td> <td>INC ECN 135550</td> <td>91-03-21</td> <td>PB Z</td> </tr> </tbody> </table>	EFF	LTR	NO.	DESCRIPTION	DATE	APPROVED	ALL	A		INC ECN 93273	88-07-25	LC CP TB		B		INC ECN 102118, EFF: 88-11-17	88-12-06	DD CP TB		C		INC ECN 102631, EFF: 01-26-89	89-02-27	DD TB		D		INC ECN 135550	91-03-21	PB Z
EFF	LTR	NO.	DESCRIPTION	DATE	APPROVED																										
ALL	A		INC ECN 93273	88-07-25	LC CP TB																										
	B		INC ECN 102118, EFF: 88-11-17	88-12-06	DD CP TB																										
	C		INC ECN 102631, EFF: 01-26-89	89-02-27	DD TB																										
	D		INC ECN 135550	91-03-21	PB Z																										

REV																					
SHEET																					
REV STATUS OF SHEETS	REV SHEET	D	A	D	B																
		1	2	3	4																

1. PREPARED IN ACCORDANCE WITH DOD-STD-100. 2. UNLESS OTHERWISE SPECIFIED, DIMENSIONS ARE IN INCHES.	ELECTROSPACE SYSTEMS, INC. DAAB07-86-C-J008	U.S. ARMY COMMUNICATIONS— ELECTRONIC COMMAND FORT MONMOUTH, NEW JERSEY 07703
	APVD D. MORUE <i>APV 87-11-05</i> ENGR D. PLEMONS <i>DP 87-10-30</i> ENGR C. PYBUS <i>CP 87-10-30</i> CHECK C. REID <i>CR 87-10-30</i> DRAWN L. CHATELAIN <i>LC 87-10-30</i>	DRAWING TITLE WIRING LIST, POINT-TO-POINT, POWER RACK
A3093151 B/A3093151	REV _____ APVD _____ NEXT ASSY USED ON DATE _____	SIZE A FSCM NO. 80063 DRAWING NO. A3093206
APPLICATION	SCALE NONE	D SHEET 1 OF 4

- NOTES:
1. REFERENCE SCHEMATIC DIAGRAM A3093208.
 2. THIS END NOT CONNECTED. ROUTE WIRES WITHIN RACK. WIRES TO BE TERMINATED AT NEXT ASSEMBLY LEVEL.
 3. STRIP WIRE END APPROXIMATELY .28 INCHES. CRIMP CONTACTS TO P1 (ITEM 5) USING AMP INCORPORATED HAND TOOL 90382-2 OR USING 90145-1 DIE WITH HAND TOOL 69710-1. SCREW ON BACKSHELL (ITEM 9) AND CONNECT P1 TO A2A4J4.
 4. TYPE APPROPRIATE "W" NUMBER ON ITEM 4 FOR EACH WIRE END. SHRINK APPROXIMATELY 3 INCHES FROM EACH END.

THIS DOCUMENT HAS BEEN PURCHASED BY THE GOVERNMENT AND MAY BE REPRODUCED AND USED IN CONNECTION WITH ANY GOVERNMENT PROCUREMENT OR MAINTENANCE OPERATION	SIZE A	FSCM NO. 80063	DRAWING NO. A3093206
	SCALE NONE	LTR A	SHEET 2

A3093206

PARTS LIST					
QTY	ITEM	PART NO.	DESCRIPTION	SPEC/STD	FSCM NO.
7	1	MS25036-112	TERMINAL LUG, RING, NO. 10, 12-10 AWG		96906
	2				
	3				
16	4	M23053/5-104-9	INSULATION SLEEVING (IN)	MIL-I-23053/5	81349
1	5	A3092921-2	CONNECTOR (P1)		80063
	6				
	7				
	8				
1	9	A3092918-2	BACKSHELL (P1)		80063
4	10	A3092919	CONTACT, SOCKET		80063
	11				
AR	E12-0	M16878/4BLE0	WIRE, 12 AWG, BLACK	MIL-W-16878/4	81349
AR	E12-2	M16878/48LE2	WIRE, 12 AWG, RED	MIL-W-16878/4	81349
AR	E12-5	M16878/4BLE5	WIRE, 12 AWG, GREEN	MIL-W-16878/4	81349
AR	E12-6	M16878/4BLE6	WIRE, 12 AWG, BLUE	MIL-W-16878/4	81349
AR	E12-9	M16878/48LE9	WIRE, 12AWG, WHITE	MIL-W-16878/4	81349

0351N	THIS DOCUMENT HAS BEEN PURCHASED BY THE GOVERNMENT AND MAY BE REPRODUCED AND USED IN CONNECTION WITH ANY GOVERNMENT PROCUREMENT OR MAINTENANCE OPERATION	SIZE	FSCM NO.	DRAWING NO.
		A	80063	A3093206
		SCALE	NONE	LTR D SHEET 3

WIRE NO. OR COLOR	FROM TERMINATION			TO TERMINATION			WIRE		FUNCTION	REMARKS
	REF DES	PIN	(I) ITEM	REF DES	PIN	(I) ITEM	ITEM	LENGTH		
W501E12-0	P1	2	I10 N3	A1A2		N2	E12-0		PHASE A	BLACK
W502E12-2	P1	3	I10 N3	A1A2		N2	E12-2		PHASE B	RED
W503E12-6	P1	4	I10 N3	A1A2		N2	E12-6		PHASE C	BLUE
W504E12-9	P1	5	I10 N3	A1A2		N2	E12-9		NEUTRAL	WHITE
W505E12-5	A1A2		N2	A1A3	E1	I1	E12-5		GROUND	GREEN
W521E12-5	A1A3	E1	I1	A1A4	E1	I1	E12-5		GROUND	GREEN
W522E12-5	A1A4	E1	I1	A2A5	E1	I1	E12-5		GROUND	GREEN
W523E12-5	A2A5	E1	I1	A2A4	E1	I1	E12-5		GROUND	GREEN

THIS DOCUMENT HAS BEEN PURCHASED BY THE GOVERNMENT AND MAY BE REPRODUCED AND USED IN CONNECTION WITH ANY GOVERNMENT PROCUREMENT OR MAINTENANCE OPERATION	SIZE	FSCM NO.	DRAWING NO.
	A	80063	A3093206
	SCALE	NONE	LTR B SHEET 4

A3093206

WIRING LIST, POINT-TO-POINT, POWER RACK (Sheets 3 & 4 of 4)

NOTE: DATA MARKED WITH AN ASTERISK IS PECULIAR TO A PRIOR MANUFACTURER. IT DOES NOT TAKE PRECEDENCE OVER ANY OTHER DATA ON THIS DRAWING, AND IS NOT CONTRACTUALLY BINDING ON EITHER THE CONTRACTOR OR THE GOVERNMENT.

THIS DOCUMENT HAS BEEN PURCHASED BY THE GOVERNMENT AND MAY BE REPRODUCED AND USED IN CONNECTION WITH ANY GOVERNMENT PROCUREMENT OR MAINTENANCE OPERATION.		REVISIONS													
		EFF	LTR	NO.	DESCRIPTION	DATE	APPROVED								
		ALL	A		INC ECN 94526	88-04-19	RR CP								
		ALL	B		INC ECN 93274, THESE SHEETS ADDED: 11 THRU 14	88-07-25	LC CP								
		ALL	C		INC ECN 88611	88-08-10	LC PRA								
		ALL	D		INC ECN 100406	88-09-28	DD CP								
			E		INC ECN 102119, EFF: 88-11-17	88-12-13	DD CP								
		ALL	F		INC ECN 101611	88-12-22	DD CP								
		ALL	G		INC ECN 97231, ADDITION OF TEXT TO DOCUMENT CHANGED THE SHEET COUNT FROM 14 TO 15	89-05-17	DD TB								
			H		INC ECN 97233, EFF: 2-22-89										

REV	SHEET																			
REV STATUS OF SHEETS		REV SHEET	J	A	D	H	G	J	G	G	G	H	G	G	G	G	G	G	G	G
			1	2	3	4	5	6	7	8	9	10	11	12	13	14	15			

1. PREPARED IN ACCORDANCE WITH DOD-STD-100. 2. UNLESS OTHERWISE SPECIFIED, DIMENSIONS ARE IN INCHES.	ELECTROSPACE SYSTEMS, INC. DAAB07-86-C-J008	U.S. ARMY COMMUNICATIONS - ELECTRONIC COMMAND FORT MONMOUTH, NEW JERSEY 07703
	APVD D. MORUE <i>AM</i> 87-11-19 ENGR M. MARTIN <i>MM</i> 87-11-17 ENGR C. PYBUS <i>CP</i> 87-11-10 CHECK C. REID <i>CR</i> 87-11-14 DRAWN L. CHATELAIN <i>LC</i> 87-11-18	DRAWING TITLE WIRING LIST, POINT-TO-POINT, POWER DISTRIBUTION/SHELTER
A3092953 DLA3092951 A3092803 DLA3092801 A3092653 DLA3092651	REV APVD DATE	SIZE A FSCM NO. 80063 DRAWING NO. A3093207 SCALE NONE SHEET 1 OF 15

- NOTES:
1. REFERENCE SCHEMATIC DIAGRAM A3093202.
 2. RING LUG TERMINALS OF W456 ARE CRIMPED USING MIL-C-22520/5-01 TOOLING WITH MIL-C-22520/5-100 DIE.
 3. ONE END OF WIRE IS ATTACHED TO RETRACTORS OF POWER RACK BAY (A2). THE OTHER END IS ROUTED FROM THE REAR OF RACK INTO WIREMOLD RACEWAY TO LEFT SIDE ENTRY OF POWER DISTRIBUTION ASSY (A17). CONNECTION IS ONLY MADE IN A17.
 4. EIGHT WIRES FROM POWER ENTRY ASSY (A1) EXIT THROUGH A ONE INCH DIAMETER OPENING AT THE BOTTOM OF THE ENCLOSURE. THESE WIRES ARE ROUTED THROUGH CONDUIT THAT RUNS ALONG THE ROADSIDE INTERIOR SHELTER WALL TO THE ENVIRONMENTAL CONTROL UNITS. THE SHORTER FOUR WIRES END DESTINATION IS THE ROADSIDE ENVIRONMENTAL CONTROL UNIT (A10). THE LONGER FOUR WIRES ARE ROUTED THROUGH A10 INTO ANOTHER RUN OF CONDUIT TO THE CURBSIDE ECU (A11). EACH SET OF WIRES IS TERMINATED TO A CABLE PLUG (ITEM 3). TYPE ON ITEM 5 THE FOLLOWING: "ENVIRONMENTAL CONTROL UNIT POWER, MATES WITH AXJ1", WHERE X WILL BE EITHER 10 OR 11, DEPENDENT UPON THE LOCATION OF THE ENVIRONMENTAL CONTROL UNIT APPLY THE MARKER ON THE APPROPRIATE WIRE BUNDLE APPROXIMATELY TWO INCHES FROM THE CONNECTOR. THEN CONNECT CONNECTOR TO J1 OF THE ENVIRONMENTAL CONTROL UNIT.
 5. FIVE WIRES FROM THE POWER ENTRY ASSY (A1) EXIT THROUGH A 1 1/2 INCH DIAMETER OPENING AT THE BOTTOM OF THE ENCLOSURE. THESE FIVE WIRES ARE ROUTED IN CONDUIT TO THE POWER FILTER IN THE POWER RACK BAY (A2).
 6. THESE WIRES HAVE ONE END THAT IS CONNECTED IN THE POWER DISTRIBUTION ASSY (A17). THE OTHER END IS ROUTED OUT THE LEFT SIDE OPENING OF A17 INTO WIREMOLD RACEWAY.
 7. THESE WIRES HAVE ONE END THAT IS CONNECTED IN THE POWER DISTRIBUTION ASSY (A17). THE OTHER END IS ROUTED OUT THE TOP OPENING OF A17 UP INTO WIREMOLD RACEWAY.

THIS DOCUMENT HAS BEEN PURCHASED BY THE GOVERNMENT AND MAY BE REPRODUCED AND USED IN CONNECTION WITH ANY GOVERNMENT PROCUREMENT OR MAINTENANCE OPERATION	SIZE	FSCM NO.	DRAWING NO.
	A	80063	A3093207
	SCALE	NONE	LTR A SHEET 2

NOTES (CONT):

8. W112 THRU W115 OF HARNESS A3093451 ARE ROUTED FROM TB4 THRU THE POWER DISTRIBUTION ASSY (A17) INTO THE WIREMOLD ABOVE A17.
9. TYPE "W456" ON TWO ONE-INCH LENGTHS OF ITEM 4. THESE MARKERS ARE SHRUNK APPROXIMATELY 2 INCHES FROM EACH WIRE END.
10. WIRE IS PART OF WIRING HARNESS A3093451.
11. WIRE IS PART OF WIRING HARNESS A3093452.
12. WIRE IS PART OF WIRING HARNESS A3093453.
13. WIRE IS PART OF WIRING HARNESS A3093454.
14. TB3 AND TB4 ARE LOCATED IN WIREMOLD RACEWAY TO THE LEFT OF POWER DISTRIBUTION ASSY (A17).
15. THIS END OF WIRE ALREADY CONNECTED AS PART OF WIRING HARNESS.
16. ALL SOLDERING PER MIL-STD-454, REQUIREMENT 5.
17. TB1 AND TB2 ARE LOCATED IN WIREMOLD RACEWAY ABOVE POWER DISTRIBUTION ASSY (A17).
18. S1 IS THE LIMIT SWITCH NEXT TO THE SHELTER DOOR.
19. DS1, DS2, DS3 AND DS4 ARE LIGHT FIXTURES IN SHELTER CEILING.
20. WIRE IS PART OF WIRE HARNESS A3093528-2. THESE WIRES ARE ROUTED THROUGH CONDUIT TO THE ROADSIDE ENVIRONMENTAL CONTROL UNIT (A10). EACH WIRE IS TERMINATED TO A CONNECTOR PLUG (ITEM 12). TYPE ON ITEM 5 THE FOLLOWING:
 A3093528-2
 FSCM 80063
 M/W A10J2
 APPLY MARKER ON WIRE BUNDLE APPROXIMATELY TWO INCHES FROM CONNECTOR.

THIS DOCUMENT HAS BEEN PURCHASED BY THE GOVERNMENT AND MAY BE REPRODUCED AND USED IN CONNECTION WITH ANY GOVERNMENT PROCUREMENT OR MAINTENANCE OPERATION	SIZE	FSCM NO.	DRAWING NO.	
	A	80063	A3093207	
	SCALE	NONE	LTR	D SHEET 3

NOTES (CONT):

21. WIRE IS PART OF WIRE HARNESS A3093528-1. THESE WIRES ARE ROUTED THROUGH CONDUIT TO THE CURBSIDE ENVIRONMENTAL CONTROL UNIT (A11). EACH WIRE IS TERMINATED TO A CONNECTOR PLUG (ITEM 12). TYPE ON ITEM 5 THE FOLLOWING:
 A3093528-1
 FSCM 80063
 M/W A11J2
 APPLY MARKER ON WIRE BUNDLE APPROXIMATELY TWO INCHES FROM CONNECTOR.
22. NO ASSEMBLY REQUIRED FOR WIRE END. WIRE IS ROUTED OUT OF LEFT SIDE OF POWER DISTRIBUTION ASSY TO POWER RACK. W485 - W487 HAVE TERMINAL LUGS AND ARE CONNECTED TO POWER FILTER. W402 AND W403 ARE TERMINATED IN "P2" CONNECTOR. "P2" IS CONNECTED TO J10 OF UPS CONTROL CHASSIS. W405 AND W488 - W490 ARE TERMINATED IN "P3" CONNECTOR. "P3" IS CONNECTED TO J1 5 OF UPS CONTROL CHASSIS.
23. WIRE CONNECTION ON THIS END PREVIOUSLY MADE AT ASSEMBLY OF DC FILTER BOX.
24. THIS WIRE END PREVIOUSLY TERMINATED ON DRAWING A3093206.
25. GROUND STUD E3 IS THE UPPER RIGHT MOUNTING STUD FOR THE LEFT MOST FILTER (A PHASE FILTER). GROUND STUD E4 IS THE UPPER RIGHT MOUNTING STUD FOR THE FILTER LOCATED ADJACENT TO THE LEFT MOST FILTER (B PHASE FILTER). GROUND STUD E5 IS LOCATED IN THE SHIELDED COMPARTMENT ON THE POWER ENTRY SIDE OF THE FILTER. SEE FIGURE 1 FOR PICTORIAL LOCATION.

THIS DOCUMENT HAS BEEN PURCHASED BY THE GOVERNMENT AND MAY BE REPRODUCED AND USED IN CONNECTION WITH ANY GOVERNMENT PROCUREMENT OR MAINTENANCE OPERATION	SIZE	FSCM NO.	DRAWING NO.	
	A	80063	A3093207	
	SCALE	NONE	LTR	H SHEET 4

A3093207

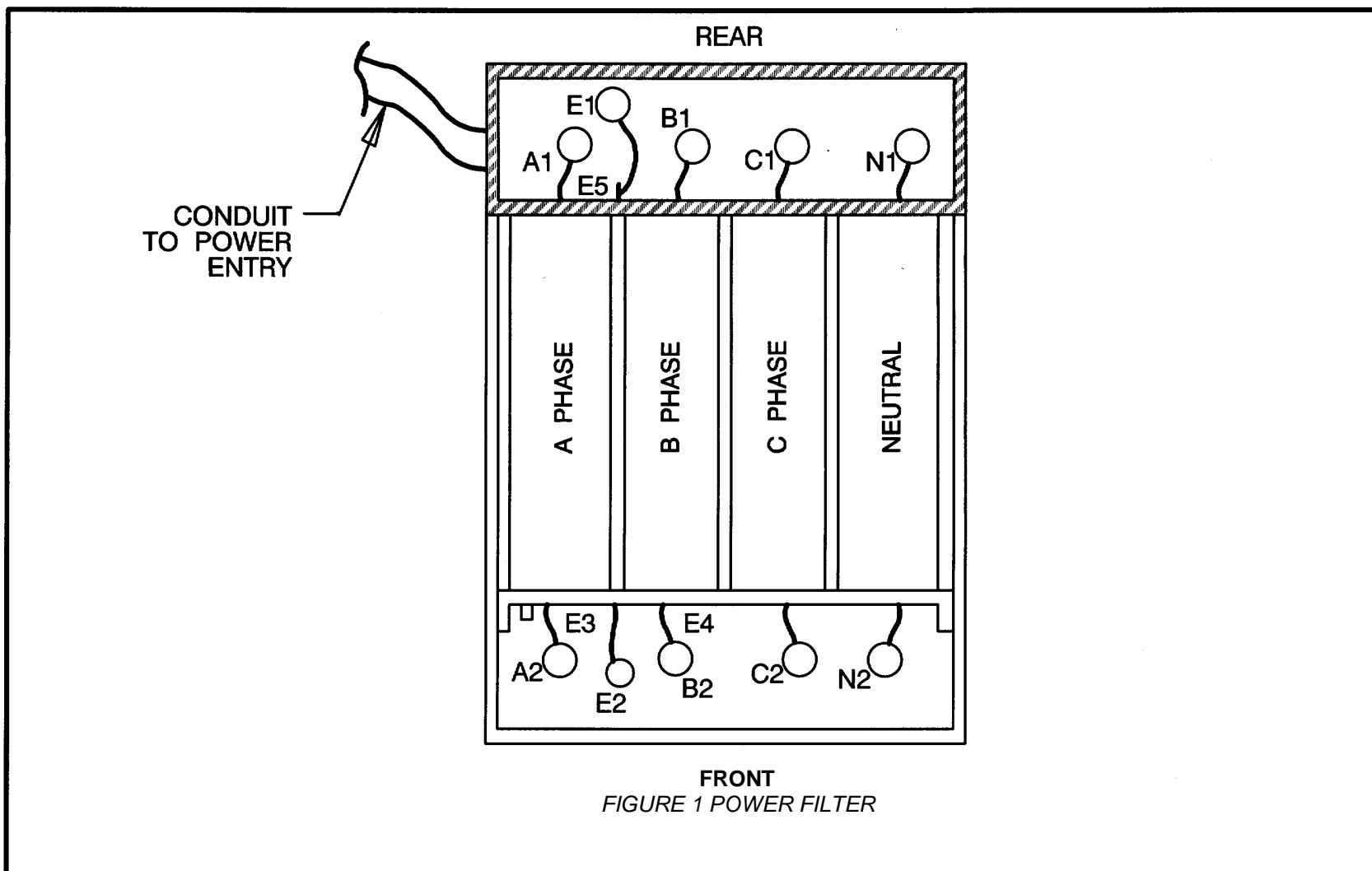

FRONT
FIGURE 1 POWER FILTER

THIS DOCUMENT HAS BEEN PURCHASED BY THE GOVERNMENT AND MAY BE REPRODUCED AND USED IN CONNECTION WITH ANY GOVERNMENT PROCUREMENT OR MAINTENANCE OPERATION	SIZE	FSCM NO.	DRAWING NO.	
	A	80063	A3093207	
SCALE	NONE	LTR	G	SHEET 5

PARTS LIST					
QTY	ITEM	PART NO.	DESCRIPTION	SPEC/STD	FSCM NO.
1	1	MS25036-153	TERMINAL LUG, RING, NO. 8, 16-14 AWG		96906
1	2	MS25036-107	TERMINAL LUG, RING, NO. 6, 16-14 AWG		96906
2	3	MS3106RI8-11S	CONNECTOR, PLUG (A100P1, A11P1)		96906
2	4	M23053/5-104-9	INSULATION SLEEVING	MIL-I-23053/5	81349
2	5	A3092925-9	CABLE MARKER		80063
9	6	MS25036-119	TERMINAL LUG, RING, NO. 10, 6 AWG		96906
2	7	MS25036-112	TERMINAL LUG, RING, NO. 10, 12-10 AWG		96906
3	8	MS20659-143	TERMINAL LUG, RING, 1/2 INCH STUD, 6 AWG		96906
1	9	MS25036-113	TERMINAL, LUG, RING, 5/16 INCH STUD, 12 AWG		96906
3	10	MS25036-120	TERMINAL, LUG, RING, 1/4 INCH STUD, 6 AWG		96906
1	11	MS25036-121	TERMINAL, LUG, RING, 5/16 INCH STUD, 6AWG		96906
REF	12	A3105766	PLUG, REMOTE CONNECTOR - MODIFIED		80063
5	13	MS25036-157	TERMINAL, LUG, RING, 1/4 INCH STUD, 12-10 AWG		96906
5	14	MS25036-123	TERMINAL, LUG, RING, 1/4 INCH STUD, 4 AWG		96906
AR	E14-2	M16878/4BKE2	WIRE, 14 AWG, RED	MIL-W-16878/4	81349
AR	E12-5	M16878/12BLE5	WIRE, 12 AWG, GREEN	MIL-W-16878/12	81349
AR	E6-5	M16878/12BPL5	WIRE, 6AWG, GREEN	MIL-W-16878/12	81349

THIS DOCUMENT HAS BEEN PURCHASED BY THE GOVERNMENT AND MAY BE REPRODUCED AND USED IN CONNECTION WITH ANY GOVERNMENT PROCUREMENT OR MAINTENANCE OPERATION	SIZE	FSCM NO.	DRAWING NO.	
	A	80063	A3093172	
SCALE	NONE	LTR	J	SHEET 6

A3093207

WIRE NO. OR COLOR	FROM TERMINATION			TO TERMINATION			WIRE		FUNCTION	REMARKS
	REF DES	PIN	(I) ITEM (N) NOTE	REF DES	PIN	(I) ITEM (N) NOTE	ITEM	LENGTH		
W101E14-2			N10 N15	TB1	1	N10 N17				RED
W102E14-9			N10 N15	TB1	2	N10 N17				WHITE
W103E14-5			N10 N15	TB1	3	N10 N17				GREEN
W107E18-92	A7A4FLI	1	N23	TB1	4	N17				WHITE/RED
W108E18-5	A7A4E1		N23	TB1	5	N17				GREEN
W109E14-2	A7J1	H	N10	TB2	1	N10 N17				RED
W110E14-9	A7J1	N	N10	TB2	2	N10 N17				WHITE
W111E14-5	A7J1	G	N10	TB2	3	N10 N17				GREEN
W112E18-92	TB4	5	N8N10N14	TB1	4	N10 N17				WHITE/RED
W113E18-5	TB4	4	N8N10N14	TB1	5	N10 N17				GREEN
W114E14-2	TB4	2	N8N10N14	DS3TB1	1	N10 N19				RED
W115E14-2	TB4	3	N8N10N14	DS4TB1	1	N10 N19				RED
W121E14-0			N11 N15	TB3	1	N11 N14				BLACK
W122E14-9			N11 N15	TB3	2	N11 N14				WHITE
W123E14-5			N11N15	TB3	3	N11 N14				GREEN
W124E14-2			N11 N15	TB4	1	N11 N14				RED
W125E14-2			N11 N15	TB4	2	N11 N14				RED
W126E20-5			N11 N15	TB4	4	N11 N14				GREEN

THIS DOCUMENT HAS BEEN PURCHASED BY THE GOVERNMENT AND MAY BE REPRO- DUCED AND USED IN CONNECTION WITH ANY GOVERNMENT PROCUREMENT OR MAINTENANCE OPERATION	SIZE A	FSCM NO. 80063	DRAWING NO. A3093207	
	SCALE NONE	LTR G	Sheet 7	

WIRE NO. OR COLOR	FROM TERMINATION			TO TERMINATION			WIRE		FUNCTION	REMARKS
	REF DES	PIN	(I) ITEM (N) NOTE	REF DES	PIN	(I) ITEM (N) NOTE	ITEM	LENGTH		
W301E14-5	DS1TB1	5	N13	DS3TB1	3	N13				GREEN
W302E14-9	DS1TB1	4	N13	DS3TB1	2	N13				WHITE
W303E14-2	DS1TB1	3	N13	DS2TB1	3	N13				RED
W304E14-2	DS1TB1	2	N13	DS2TB1	2	N13				RED
W305E14-2	DS1TB1	1	N13	DS2TB1	1	N13				RED
W306E14-5	DS3TB1	3	N13	DS2TB1	5	N13				GREEN
W307E14-9	DS3TB1	2	N13	DS2TB1	4	N13				WHITE
W308E14-9	DS3TB1	2	N13	DS4TB1	2	N13				WHITE
W309E14-5	DS3TB1	3	N13	DS4TB1	3	N13				GREEN
W402E14-92			N6 A2A1A1J10			N22				WHT/RED
W403E14-90			N6 A2A1A1J10			N22				WHT/BLK
W405E12-0			N6 A2A1A1J15			N22				BLACK
W410E18-92			N7	TB1	4	N17				WHT/RED
W411E18-5			N7	TB1	5	N17				GREEN
W412E14-0			N6	TB3	1	N14				BLACK

THIS DOCUMENT HAS BEEN PURCHASED BY THE GOVERNMENT AND MAY BE REPRO- DUCED AND USED IN CONNECTION WITH ANY GOVERNMENT PROCUREMENT OR MAINTENANCE OPERATION	SIZE A	FSCM NO. 80063	DRAWING NO. A3093207	
	SCALE NONE	LTR G	Sheet 8	

A3093207

WIRE NO. OR COLOR	FROM TERMINATION			TO TERMINATION			WIRE		FUNCTION	REMARKS
	REF DES	PIN	(I) ITEM (N) NOTE	REF DES	PIN	(I) ITEM (N) NOTE	ITEM	LENGTH		
W413E14-9			N6	TB3	2	N14				WHITE
W414E14-5			N6	TB3	3	N14				GREEN
W415E14-2			N7	TB2	1	N17				RED
W416E14-9			N7	TB2	2	N17				WHITE
W417E14-5			N7	TB2	3	N17				GREEN
W418E14-2			N7	TB1	1	N17				RED
W419E14-9			N7	TB1	2	N17				WHITE
W420E14-5			N7	TB1	3	N17				GREEN
W427E14-2			N7	S1	2	N18				RED
W428E12-0			N4	A10P1	A	I3 N4				BLACK
W429E12-2			N4	A10P1	B	I3 N4				RED
W430E12-6			N4	A10OP1	C	I3 N4				BLUE
W432E12-5			N4	A10OP1	D	I3 N4				GREEN
W433E12-0			N4	A11 P1	A	I3 N4				BLACK
W434E12-2			N4	A11P1	B	I3 N4				RED
W435E12-6			N4	A11P1	C	I3 N4				BLUE
W437E12-5			N4	A11P1	D	I3 N4				GREEN
W438E4-0			N5	A2A1A2	A1	I14				BLACK

THIS DOCUMENT HAS BEEN PURCHASED BY THE GOVERNMENT AND MAY BE REPRODUCED AND USED IN CONNECTION WITH ANY GOVERNMENT PROCUREMENT OR MAINTENANCE OPERATION	SIZE A	FSCM NO. 80063	DRAWING NO. A3093207	
	SCALE NONE	LTR G	Sheet 9	

WIRE NO. OR COLOR	FROM TERMINATION			TO TERMINATION			WIRE		FUNCTION	REMARKS
	REF DES	PIN	(I) ITEM (N) NOTE	REF DES	PIN	(I) ITEM (N) NOTE	ITEM	LENGTH		
W439E4-2			N5	A2A1A2	B1	I14				RED
W440E4-6			N5	A2A1A2	C1	I14				BLUE
W441E4-9			N5	A2A1A2	D1	I14				WHITE
W442E4-5			N5	A2A1A2	E5	I14 N25				GREEN
W443E14-9			N7	DS4TB1	2					WHITE
W444E14-5			N7	DS4TB1	3					GREEN
W445E14-2			N7	S1	4	N18				RED
W446E14-2			N7	DS1TB1	2	N19				RED
W447E14-2			N7	DS1TB1	3	N19				RED
W453E14-2			N6	TB4	1	N14				RED
W456E14-2	DS1TB1	1	11N2N9	S1	1	12N9N18	E14-2			RED
W482E14-6			N7	A3A1TB1	3					BLUE
W483E14-9			N7	A3A1TB1	4					WHITE
W484E14-5			N7	A3A1TB1	5					GREEN
W485E12-5			N6	A2A1A2	E3	N22 N25				GREEN
W486E12-9			N6	A2A1A2	N2	N22				WHITE
W487E12-2			N6	A2A1A2	B2	N22				RED
W457E14-2	S1	2	12 N18	S1	3	12 N18	E14-2			RED

THIS DOCUMENT HAS BEEN PURCHASED BY THE GOVERNMENT AND MAY BE REPRODUCED AND USED IN CONNECTION WITH ANY GOVERNMENT PROCUREMENT OR MAINTENANCE OPERATION	SIZE A	FSCM NO. 80063	DRAWING NO. A3093207	
	SCALE NONE	LTR H	Sheet 10	

A3093207

WIRING LIST, POINT-TO-POINT, POWER DISTRIBUTION/SHELTER (Sheets 9 & 10 of 15)

WIRE NO. OR COLOR	FROM TERMINATION			TO TERMINATION			WIRE		FUNCTION	REMARKS
	REF DES	PIN	(I) ITEM (N) NOTE	REF DES	PIN	(I) ITEM (N) NOTE	ITEM	LENGTH		
W488E1 2-2			N6	A2A1A1J15		N22				RED
W489E1 2-6			N6	A2A1A1J15		N22				BLUE
W490E12-9			N6	A2A1A1J15		N22				WHITE
W492E14-0			N7	A3A3TB1	1					BLACK
W493E14-2			N7	A3A3TB1	2					RED
W494E14-6			N7	A3A3TB1	3					BLUE
W495E14-9			N7	A3A3TB1	4					WHITE
W496E14-5			N7	A3A3TB1	5					GREEN
W497E14-6			N7	A3A2TB1	3					BLUE
W498E14-9			N7	A3A2TB1	4					WHITE
W499E14-5			N7	A3A2TB1	5					GREEN
W901 E6-5	A3A2E1		16	A1E6		18	E6-5			GREEN
W902E12-5	A6E1		17	WT1		19	E12-5			GREEN
W903E6-5	WT1		111	A17E1		16	E6-5			GREEN
W904E6-5	A17E1		16	A2A1 E1		16	E6-5			GREEN
W905E6-5	A2A1E1		16	A1 E6		18	E6-5			GREEN
W906E6-5	A7E1		110	A15E1		110	E6-5			GREEN
W907E6-5	A15E1		110	A1 E6		18	E6-5			GREEN

THIS DOCUMENT HAS BEEN PURCHASED BY THE GOVERNMENT AND MAY BE REPRO- DUCED AND USED IN CONNECTION WITH ANY GOVERNMENT PROCUREMENT OR MAINTENANCE OPERATION	SIZE	FSCM NO.	DRAWING NO.	
	A	80063	A3093207	
SCALE	NONE	LTR	G	SHEET 11

WIRE NO. OR COLOR	FROM TERMINATION			TO TERMINATION			WIRE		FUNCTION	REMARKS
	REF DES	PIN	(I) ITEM (N) NOTE	REF DES	PIN	(I) ITEM (N) NOTE	ITEM	LENGTH		
W127E20-92				N11 N15	TB4	5	N11 N14			WHITE/RED
W131E14-0			N12 N15	TB3	1	N12 N14				BLACK
W132E14-9			N12 N15	TB3	2	N12 N14				WHITE
W133E14-5			N12 N15	TB3	3	N12 N14				GREEN
W134E14-2			N12 N15	TB4	1	N12 N14				RED
W135E14-2			N12 N15	TB4	3	N12 N14				RED
W136E20-5			N12 N15	TB4	4	N12 N14				GREEN
W137E20-92				N12 N15	TB4	5	N12 N14			WHITE/RED
91			N20	A10P2	A1	N16 N20				WHT/BRN
92			N20	A10P2	A2	N16 N20				WHT/RED
95			N20	A10P2	A3	N16 N20				WHT/GRN
906			N20	A10P2	A4	N16 N20				WHT/BLK/BLU
905			N20	A10P2	A5	N16 N20				WHT/BLK/GRN
98			N20	A10P2	A6	N16 N20				WHT/GRY
901			N20	A10P2	A7	N16 N20				WHT/BLK/BRN
94			N20	A10P2	A8	N16 N20				WHT/YEL
93			N20	A10P2	A9	N16 N20				WHT/ORN

THIS DOCUMENT HAS BEEN PURCHASED BY THE GOVERNMENT AND MAY BE REPRO- DUCED AND USED IN CONNECTION WITH ANY GOVERNMENT PROCUREMENT OR MAINTENANCE OPERATION	SIZE	FSCM NO.	DRAWING NO.	
	A	80063	A3093207	
SCALE	NONE	LTR	G	SHEET 12

A3093207

WIRING LIST, POINT-TO-POINT, POWER DISTRIBUTION/SHELTER (Sheets 11 & 12 of 15)

WIRE NO. OR COLOR	FROM TERMINATION			TO TERMINATION			WIRE		FUNCTION	REMARKS
	REF DES	PIN	(I) ITEM (N) NOTE	REF DES	PIN	(I) ITEM (N) NOTE	ITEM	LENGTH		
4			N20	A10P2	A11	N16N20				YEL
0			N20	A10P2	A12	N16N20				BLK
2			N20	A10P2	A13	N16N20				RED
6			N20	A10P2	A14	N16N20				BLU
5			N20	A10P2	A15	N16N20				GRN
9			N20	A10P2	A16	N16N20				WHT
8			N20	A10P2	B2	N16N20				GRY
908			N20	A10P2	B3	N16N20				WHT/BLK/GRA
907			N20	A10P2	B4	N16N20				WHT/BLK/VIO
914			N20	A10P2	B5	N16N20				WHT/BRN/YEL
96			N20	A10P2	B6	N16N20				WHT/BLU
7			N20	A10P2	B7	N16N20				VIO
913			N20	A10P2	B8	N16N20				WHT/BRN/ORN
90			N20	A10P2	B9	N16N20				WHT/BLK
912			N20	A10P2	B10	N16N20				WHT/BRN/RED
3			N20	A10P2	B11	N16N20				ORN
91			N21	A11P2	A1	N16N21				WHT/BRN

THIS DOCUMENT HAS BEEN PURCHASED BY THE GOVERNMENT AND MAY BE REPRODUCED AND USED IN CONNECTION WITH ANY GOVERNMENT PROCUREMENT OR MAINTENANCE OPERATION	SIZE	FSCM NO.	DRAWING NO.
	A	80063	A3093207
SCALE		NONE	LTR G SHEET 13

WIRE NO. OR COLOR	FROM TERMINATION			TO TERMINATION			WIRE		FUNCTION	REMARKS
	REF DES	PIN	(I) ITEM (N) NOTE	REF DES	PIN	(I) ITEM (N) NOTE	ITEM	LENGTH		
92			N21	A11P2	A2	N16N21				WHT/RED
95			N21	A11P2	A3	N16N21				WHT/GRN
906			N21	A11P2	A4	N16N21				WHT/BLK/BLU
905			N21	A11P2	A5	N16N21				WHT/BLK/GRN
98			N21	A11P2	A6	N16N21				WHT/GRA
901			N21	A11P2	A7	N16N21				WHT/BLK/BRN
94			N21	A11P2	A8	N16N21				WHT/YEL
93			N21	A11P2	A9	N16N21				WHT/ORN
4			N21	A11P2	A11	N16N21				YEL
0			N21	A11P2	A12	N16N21				BLK
2			N21	A11P2	A13	N16N21				RED
6			N21	A11P2	A14	N16N21				BLU
5			N21	A11P2	A15	N16N21				GRN
9			N21	A11P2	A16	N16N21				WHT
8			N21	A11P2	B2	N16N21				GRA
908			N21	A11P2	B3	N16N21				WHT/BLK/GRA
907			N21	A11P2	B4	N16N21				WHT/BLK/VIO

THIS DOCUMENT HAS BEEN PURCHASED BY THE GOVERNMENT AND MAY BE REPRODUCED AND USED IN CONNECTION WITH ANY GOVERNMENT PROCUREMENT OR MAINTENANCE OPERATION	SIZE	FSCM NO.	DRAWING NO.
	A	80063	A3093207
SCALE		NONE	LTR G SHEET 14

A3093207

WIRE NO. OR COLOR	FROM TERMINATION			TO TERMINATION			WIRE		FUNCTION	REMARKS
	REF DES	PIN	(I) ITEM (N) NOTE	REF DES	PIN	(I) ITEM (N) NOTE	ITEM	LENGTH		
913			N21	A11P2	B8	N16N21				WHT/BRN/ORN
90			N21	A11P2	B9	N16N21				WHT/BLK
912			N21	A11P2	B10	N16N21				WHT/BRN/RED
3			N21	A11P2	B11	N16N21				ORN
W501E12-0			N24	A2A1A2	A2	I13				BLACK
W502E12-2			N24	A2A1A2	B2	I13				RED
W503E12-6			N24	A2A1A2	C2	I13				BLUE
W504E12-9			N24	A2A1A2	N2	I13				WHITE
W505E12-5			N24	A2A1A2	E4	I13N25				GREEN

THIS DOCUMENT HAS BEEN PURCHASED BY THE GOVERNMENT AND MAY BE REPRO- DUCED AND USED IN CONNECTION WITH ANY GOVERNMENT PROCUREMENT OR MAINTENANCE OPERATION	SIZE	FSCM NO.	DRAWING NO.	
	A	80063	A3093207	
SCALE	NONE	LTR	G	SHEET 15

A3093207

WIRING LIST, POINT-TO-POINT, POWER DISTRIBUTION/SHELTER (Sheet 15 of 15)

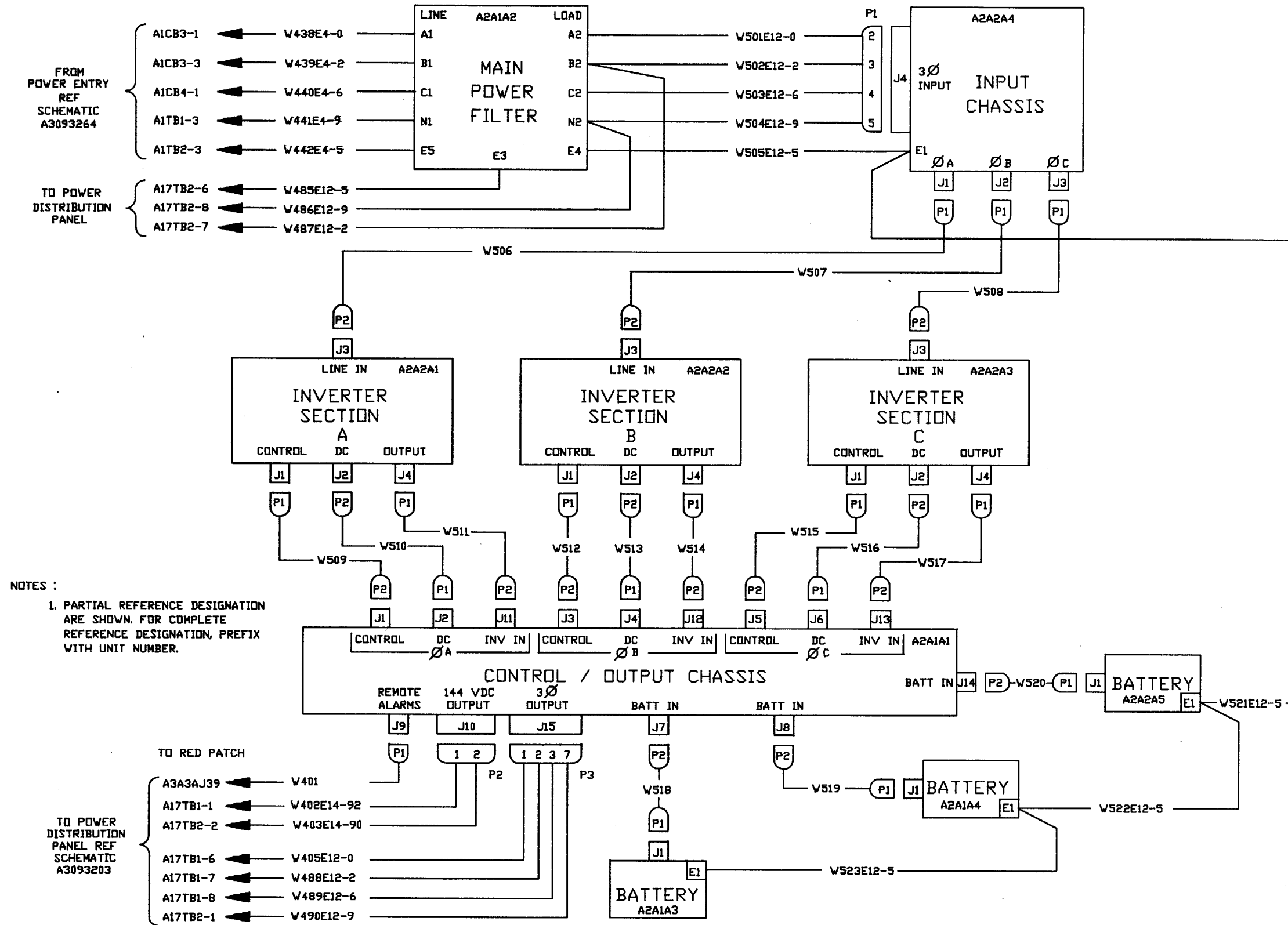

Schematic Diagram, Power Distribution - Power Rack

NOTE: DATA MARKED WITH AN ASTERISK IS PECULIAR TO A PRIOR MANUFACTURER. IT DOES NOT TAKE PRECEDENCE OVER ANY OTHER DATA ON THIS DRAWING, AND IS NOT CONTRACTUALLY BINDING ON EITHER THE CONTRACTOR OR THE GOVERNMENT.

THIS DOCUMENT HAS BEEN PURCHASED BY THE GOVERNMENT AND MAY BE REPRODUCED AND USED IN CONNECTION WITH ANY GOVERNMENT PROCUREMENT OR MAINTENANCE OPERATION.

REVISIONS					
EFF	LTR	NO.	DESCRIPTION	DATE	APPROVED
ALL	A		INC ECN 90462	87-12-21	RR <i>CP</i>
ALL	B		INC ECN 94527	88-03-14	RR <i>CP</i>
ALL	C		INC ECN 91775	88-04-19	RR <i>CP</i>
ALL	D		INC ECN 92882	88-05-27	LC <i>CP</i>
ALL	E		INC ECN 93276	88-07-26	LC <i>CP</i>
ALL	F		INC ECN 100381, ADDITION OF TEXT TO DOCUMENT CHANGED THE SHEET COUNT FROM 12 TO 13.	88-09-21	DD <i>CP</i>
	G		INC ECN 135569.	91-03-18	PB <i>5711</i>

REV SHEET																			
REV STATUS OF SHEETS		REV SHEET	G 1	B 2	E 3	G 4	G 5	G 6	F 7	F 8	F 9	F 10	F 11	F 12	F 13				
1. PREPARED IN ACCORDANCE WITH DOD-STD-100. 2. UNLESS OTHERWISE SPECIFIED, DIMENSIONS ARE IN INCHES.			ELECTROSPACE SYSTEMS, INC. DAAB07-86-C-J008				U.S. ARMY COMMUNICATIONS - ELECTRONIC COMMAND FORT MONMOUTH, NEW JERSEY 07703				DRAWING TITLE WIRING LIST, POINT-TO-POINT, POWER DISTRIBUTION PANEL								
			APVD	D. MORUE	<i>DM</i>	87-09-22													
			ENGR	D. PLEMONS	<i>DP</i>	87-09-18													
			ENGR	C. PYBUS	<i>CP</i>	87-09-14													
			CHECK	C. REID	<i>CR</i>	87-09-22													
			DRAWN	L. CHATELAIN	<i>LC</i>	87-09-14													
			REV																
A3093201	DLA3093201	APVD																	
NEXT ASSY	USED ON	DATE																	
APPLICATION			SIZE	FSCM NO.	DRAWING NO.														
			A	80063	A3093209														
			SCALE	NONE	G	SHEET 1 OF 13													

NOTES:

- REFERENCE SCHEMATIC DIAGRAM A3093203.
- SOLDER PER MIL-STD-454, REQUIREMENT 5. COVER SOLDER CONNECTION WITH ITEM 12.
- RING LUG TERMINALS ARE CRIMPED USING MIL-C-22520/5-01 TOOLING WITH MIL-C-22520/5-100 DIES INSTALLED FOR WIRE SIZES 26 THRU 10, OR MIL-C-22520/10-01 TOOLING WITH MIL-C-22520/10-101 DIES INSTALLED FOR WIRE SIZES 26 THRU 14 AND MIL-C-22520/10-100 DIES INSTALLED FOR WIRE SIZES 12 THRU 10.
- ALL WIRES THAT HAVE ONE END THAT IS NOT CONNECTED WILL HAVE RING LUG TERMINALS ON THE UNCONNECTED END. THE APPROPRIATE ENCLOSURE OPENINGS FOR THE EXIT OF THESE WIRES ARE DEFINED BY NOTES 6 OR 7. WIRE LENGTH WILL BE MEASURED FROM THE ENCLOSURE OPENING TO THE UNCONNECTED END. IDENTIFY EACH OF THESE WIRES BY TYPING THE "W" NUMBER ON ITEM 11 AND SHRINKING ONTO WIRE APPROXIMATELY 3 INCHES FROM END.
- WIRE SHALL PASS THROUGH CURRENT TRANSFORMER HOLE THEN LOOP BACK AND PASS THROUGH AGAIN BEFORE EACH END IS TERMINATED. REFER TO A3093203 FOR CORRECT WIRE/CURRENT TRANSFORMER COMBINATIONS.
- THE UNCONNECTED END OF THIS WIRE WILL EXIT OUT THE LEFT SIDE OF THE ENCLOSURE. AFTER ALL WIRES THAT EXIT THROUGH THIS OPENING ARE ROUTED OUT OF THE ENCLOSURE COIL UP AND TIE WRAP EXPOSED WIRE.
- THE UNCONNECTED END OF THIS WIRE WILL EXIT OUT THE TOP OPENING OF THE ENCLOSURE. AFTER ALL WIRES THAT EXIT THROUGH THIS OPENING ARE ROUTED OUT OF THE ENCLOSURE COIL UP AND TIE WRAP EXPOSED WIRE.
- IDENTIFY EACH WIRE END BY TYPING APPROPRIATE "W" NUMBER ON ONE END AND ONE-HALF INCH LENGTH OF ITEM 12. SHRINK MARKER APPROXIMATELY 2 INCHES FROM END.
- WIRE LENGTHS ARE IN INCHES.

THIS DOCUMENT HAS BEEN PURCHASED BY THE GOVERNMENT AND MAY BE REPRODUCED AND USED IN CONNECTION WITH ANY GOVERNMENT PROCUREMENT OR MAINTENANCE OPERATION	SIZE	FSCM NO.	DRAWING NO.	
	A	80063	A3093209	
	SCALE	NONE	LTR	SHEET 2

A3093209

NOTES (CONT):

- 10. THE UNCONNECTED END OF THIS WIRE WILL EXIT OUT THE LEFT SIDE OF THE ENCLOSURE. STRIP END APPROXIMATELY .28 INCHES. CRIMP CONTACTS (ITEM 13) USING AMP INCORPORATED HAND TOOL 90382-2 OR USING 90145-1 DIE WITH HAND TOOL 69710-1. ASSEMBLE CONNECTOR USING ITEMS 14 AND 15.
- 11. THE UNCONNECTED END OF THIS WIRE WILL EXIT OUT THE LEFT SIDE OF THE ENCLOSURE. STRIP END APPROXIMATELY .28 INCHES. CRIMP CONTACTS (ITEM 13) USING AMP INCORPORATED HAND TOOL 90382-2 OR USING 90145-1 DIE WITH HAND TOOL 69710-1. ASSEMBLE CONNECTOR USING ITEMS 16 AND 17.

0286N	THIS DOCUMENT HAS BEEN PURCHASED BY THE GOVERNMENT AND MAY BE REPRODUCED AND USED IN CONNECTION WITH ANY GOVERNMENT PROCUREMENT OR MAINTENANCE OPERATION	SIZE	FSCM NO.	DRAWING NO.	
		A	80063	A3093209	
		SCALE	NONE	LTR	E SHEET 3

PARTS LIST					
QTY	ITEM	PART NO.	DESCRIPTION	SPEC/STD	FSCM NO.
13	1	MS25036-102	TERMINAL LUG, RING, NO. 6, 22-18 AWG		96906
23	2	MS25036-103	TERMINAL LUG, RING, NO. 10, 22-18 AWG		96906
8	3	MS25036-107	TERMINAL LUG, RING, NO. 6, 16-14 AWG		96906
56	4	MS25036-108	TERMINAL LUG, RING, NO. 10, 16-14 AWG		96906
5	5	MS25036-111	TERMINAL LUG, RING, NO. 6, 12-10 AWG		96906
32	6	MS25036-112	TERMINAL LUG, RING, NO. 10, 12-10 AWG		96906
4	7	MS25036-148	TERMINAL LUG, RING, NO. 4, 22-18 AWG		96906
10	8	MS25036-149	TERMINAL LUG, RING, NO. 8, 22-18 AWG		96906
7	9	MS25036-150	TERMINAL LUG, RING, 1/4, 22-18 AWG		96906
2	10	MS25036-153	TERMINAL LUG, RING, NO. 8, 16-14 AWG		96906
47	11	M23053/5-104-9	INSULATION SLEEVING	MIL-I-23053/5A	81349
AR	12	M23053/5-103-4	INSULATION SLEEVING	MIL-I-23053/5A	81349
6	13	A3092928	CONTACT, PIN		80063
1	14	A3092921-4	CONNECTOR (P2)		80063
1	15	A3092918-1	BACKSHELL		80063
1	16	A3092921-3	CONNECTOR (P3)		80063
1	17	A3092918-2	BACKSHELL		80063

THIS DOCUMENT HAS BEEN PURCHASED BY THE GOVERNMENT AND MAY BE REPRODUCED AND USED IN CONNECTION WITH ANY GOVERNMENT PROCUREMENT OR MAINTENANCE OPERATION	SIZE	FSCM NO.	DRAWING NO.	
	A	80063	A3093209	
		SCALE	NONE	LTR G SHEET 4

PARTS LIST					
QTY	ITEM	PART NO.	DESCRIPTION	SPEC/STD	FSCM NO.
AR	E12-0	M16878/4BLE0	WIRE, 12 AWG, BLACK	MIL-W-16878/4	81349
AR	E12-2	M16878/4BLE2	WIRE, 12 AWG, RED	MIL-W-16878/4	81349
AR	E12-6	M16878/4BLE6	WIRE, 12 AWG, BLUE	MIL-W-16878/4	81349
AR	E12-9	M16878/4BLE9	WIRE, 12 AWG, WHITE	MIL-W-16878/4	81349
AR	E14-0	M16878/4BKE0	WIRE, 14 AWG, BLACK	MIL-W-16878/4	81349
AR	E14-2	M16878/4BKE2	WIRE, 14 AWG, RED	MIL-W-16878/4	81349
AR	E14-5	M16878/4BKE5	WIRE, 14 AWG, GREEN	MIL-W-16878/4	81349
AR	E14-6	M16878/4BKE6	WIRE, 14 AWG, BLUE	MIL-W-16878/4	81349
AR	E14-9	M16878/4BKE9	WIRE, 14 AWG, WHITE	MIL-W-16878/4	81349
AR	E14-90	M16878/4BKE90	WIRE, 14 AWG, WHITE/BLACK	MIL-W-16878/4	81349
AR	E14-92	M16878/4BKE92	WIRE, 14 AWG, WHITE/RED	MIL-W-16878/4	81349
AR	E18-0	M16878/4BHE0	WIRE, 18 AWG, BLACK	MIL-W-16878/4	81349
AR	E18-2	M16878/4BHE2	WIRE, 18 AWG, RED	MIL-W-16878/4	81349
AR	E18-5	M16878/4BHE5	WIRE, 18 AWG, GREEN	MIL-W-16878/4	81349
AR	E18-6	M16878/4BHE6	WIRE, 18 AWG, BLUE	MIL-W-16878/4	81349
AR	E18-9	M16878/4BHE9	WIRE, 18 AWG, WHITE	MIL-W-16878/4	81349
AR	E18-90	M16878/4BHE90	WIRE, 18 AWG, WHT/BLK	MIL-W-16878/4	81349

0286N	THIS DOCUMENT HAS BEEN PURCHASED BY THE GOVERNMENT AND MAY BE REPRODUCED AND USED IN CONNECTION WITH ANY GOVERNMENT PROCUREMENT OR MAINTENANCE OPERATION	SIZE	FSCM NO.	DRAWING NO.	
		A	80063	A3093209	
		SCALE	NONE	LTR	G SHEET 5

PARTS LIST					
QTY	ITEM	PART NO.	DESCRIPTION	SPEC/STD	FSCM NO.
AR	E18-92	M16878/4BHE92	WIRE, 18 AWG, WHITE/RED	MIL-W-16878/4	81349
AR	E22-0	M16878/4BFE0	WIRE, 22 AWG, BLACK	MIL-W-16878/4	81349
AR	E22-2	M16878/4BFE2	WIRE, 22 AWG, RED	MIL-W-16878/4	81349
AR	E22-5	M16878/4BFE5	WIRE, 22 AWG, GREEN	MIL-W-16878/4	81349
AR	E22-6	M16878/4BFE6	WIRE, 22 AWG, BLUE	MIL-W-16878/4	81349
AR	E22-9	M16878/4BFE9	WIRE, 22 AWG, WHITE	MIL-W-16878/4	81349
AR	E22-90	M16878/4BFE90	WIRE, 22 AWG, WHT/BLK	MIL-W-16878/4	81349
AR	E22-92	M16878/4BFE92	WIRE, 22 AWG, WHITE/RED	MIL-W-16878/4	81349

THIS DOCUMENT HAS BEEN PURCHASED BY THE GOVERNMENT AND MAY BE REPRODUCED AND USED IN CONNECTION WITH ANY GOVERNMENT PROCUREMENT OR MAINTENANCE OPERATION	SIZE	FSCM NO.	DRAWING NO.	
	A	80063	A3093209	
		SCALE	NONE	LTR G SHEET 6

A3093209

WIRE NO. OR COLOR	FROM TERMINATION			TO TERMINATION			WIRE		FUNCTION	REMARKS
	REF DES	PIN	(I) ITEM (N) NOTE	REF DES	PIN	(I) ITEM (N) NOTE	ITEM	LENGTH		
W101E12-6	CB2	1	I6	CB1	6	16	E12-6	14	PHASE C	BLUE
W102E12-6	CB3	1	I6	CB2	1	16	E12-6	15	PHASE C	BLUE
W103E12-6	CB4	5	I6	CB3	1	16	E12-6	19	PHASE C	BLUE
W104E12-2	CB4	3	I6	CB1	4	16	E12-2	24	PHASE B	RED
W105E12-0	CB4	1	I6	CB1	2	16	E12-0	18	PHASE A	BLACK
W106E12-0	CB5	1	I6	CB4	1	16	E12-0	18	PHASE A	BLACK
W107E12-2	CB6	1	I6	CB4	3	16	E12-2	18	PHASE B	RED
W108E12-2	CB7	1	I6	CB6	1	16	E12-2	18	PHASE B	RED
W109E12-2	CB8	1	I6	CB7	1	16	E12-2	18	PHASE B	RED
W110E22-2	CB1	4	I2	DS1	2	N2	E22-2	19	PHASE B	RED
W111E22-6	CB2	2	I2	DS2	2	N2	E22-6	12	PHASE C	BLUE
W112E22-6	CB3	2	I2	DS3	2	N2	E22-6	12	PHASE C	BLUE
W113E22-0	CB4	2	I2	DS4	2	N2	E22-0	12	PHASE A	BLACK
W114E22-0	CB5	2	I2	DS5	2	N2	E22-0	12	PHASE A	BLACK
W115E22-2	CB6	2	I2	DS6	2	N2	E22-2	12	PHASE B	RED
W116E22-2	CB7	2	I2	DS7	2	N2	E22-2	12	PHASE B	RED
W117E22-2	CB8	2	I2	DS8	2	N2	E22-2	12	PHASE B	RED

0286N	THIS DOCUMENT HAS BEEN PURCHASED BY THE GOVERNMENT AND MAY BE REPRODUCED AND USED IN CONNECTION WITH ANY GOVERNMENT PROCUREMENT OR MAINTENANCE OPERATION	SIZE	FSCM NO.	DRAWING NO.
		A	80063	A3093209
		SCALE	NONE	LTR F SHEET 7

WIRE NO. OR COLOR	FROM TERMINATION			TO TERMINATION			WIRE		FUNCTION	REMARKS
	REF DES	PIN	(I) ITEM (N) NOTE	REF DES	PIN	(I) ITEM (N) NOTE	ITEM	LENGTH		
W118E18-6	CB1	5	I2	S1	E1	I1	E18-6	24	PHASE C	BLUE
W119E18-2	CB1	3	I2	S1	D1	I1	E18-2	24	PHASE B	RED
W120E18-0	CB1	1	I2	S1	C1	I1	E18-0	24	PHASE A	BLACK
W121E18-9	CT2	2	I8	CT3	2	I8	E18-9	13	CT COMMON	WHITE
W122E18-9	CT1	2	I8	CT2	2	I8	E18-9	13	CT COMMON	WHITE
W123E18-9	CT3	2	I8	M2	2	I9	E18-9	74	CT COMMON	WHITE
W124E14-2	CB8	2	I4	S2	2	I3	E14-2	15	PHASE B	RED
W125E22-9	DS1	1	N2	DS2	1	N2	E22-9	18	NEUTRAL	WHITE
W126E22-9	DS2	1	N2	DS3	1	N2	E22-9	18	NEUTRAL	WHITE
W127E22-9	DS3	1	N2	DS4	1	N2	E22-9	18	NEUTRAL	WHITE
W128E22-9	DS4	1	N2	DS5	1	N2	E22-9	18	NEUTRAL	WHITE
W129E22-9	DS5	1	N2	DS6	1	N2	E22-9	18	NEUTRAL	WHITE
W130E22-9	DS6	1	N2	DS7	1	N2	E22-9	18	NEUTRAL	WHITE
W131E22-9	DS7	1	N2	DS8	1	N2	E22-9	18	NEUTRAL	WHITE
W132E12-9	TB2	1	I6	S4	6	15	E12-9	41	NEUTRAL	WHITE
W133E22-92	DS9	1	N2	CB9	1	12	E22-92	6	28 VDC	WHT/RED
W134E22-5	PS2	-OUT	N2	DS9	3	N2	E22-5	40	GROUND	GREEN

	THIS DOCUMENT HAS BEEN PURCHASED BY THE GOVERNMENT AND MAY BE REPRODUCED AND USED IN CONNECTION WITH ANY GOVERNMENT PROCUREMENT OR MAINTENANCE OPERATION	SIZE	FSCM NO.	DRAWING NO.
		A	80063	A3093209
		SCALE	NONE	LTR F SHEET 8

WIRE NO. OR COLOR	FROM TERMINATION			TO TERMINATION			WIRE		FUNCTION	REMARKS
	REF DES	PIN	(I) ITEM (N) NOTE	REF DES	PIN	(I) ITEM (N) NOTE	ITEM	LENGTH		
W135E18-0	S1	H1	I1	M1	1	N2	E18-0	23	V METER LEAD	BLACK
W136E18-0	M1	1	I9	K1	1	I1	E18-0	18	XDCR LEAD	BLACK
W137E18-9	M1	2	I9	K1	2	I1	E18-9	24	NEUTRAL	WHITE
W138E18-9	TB1	5	I2	M1	2	I9	E18-9	49	NEUTRAL	WHITE
W139E18-0	S1	H2	I1	M2	1	I9	E18-0	20	A METER LEAD	BLACK
W140E18-6	CT3	1	I8	S1	E2	I1	E18-6	53	PHASE C	BLUE
W141E18-2	CT2	1	I8	S1	D2	I1	E18-2	55	PHASE B	RED
W142E18-0	CT1	1	I8	S1	C2	I1	E18-0	57	PHASE A	BLACK
W143E14-2	S2	1	I3	S3	2	I3	E14-2	12	PHASE B	RED
W144E22-92	PS1	3	I7	M4	+	N2	E22-92	52	28 VDC	WHT/RED
W145E22-90	PS1	5	I7	M4	-	N2	E22-90	52	DC COMMON	WHT/BLK
W146E22-5	DS9	2	N2	CB9	NO	N2	E22-5	8	GROUND	GREEN
W147E18-92	PS2	+OUT	N2	CB9	1	I2	E18-92	42	28 VDC	WHT/RED
W148E18-90	M3	-	I9	K1	-	I1	E18-90	10	F METER NEG	WHT/BLK
W149E18-92	M3	+	I9	K1	+	I1	E18-92	10	F METER POS	WHT/RED
W150E12-0	TB1	6	I6	CB1	1	16N5	E12-0	90	PHASE A	BLACK
W151E12-2	TB1	7	I6	S4	3	16N5	E12-2	72	PHASE B	RED

0286N	THIS DOCUMENT HAS BEEN PURCHASED BY THE GOVERNMENT AND MAY BE REPRODUCED AND USED IN CONNECTION WITH ANY GOVERNMENT PROCUREMENT OR MAINTENANCE OPERATION	SIZE	FSCM NO.	DRAWING NO.		
		A	80063	A3093209		
		SCALE	NONE	LTR	F	SHEET 9

WIRE NO. OR COLOR	FROM TERMINATION			TO TERMINATION			WIRE		FUNCTION	REMARKS
	REF DES	PIN	(I) ITEM (N) NOTE	REF DES	PIN	(I) ITEM (N) NOTE	ITEM	LENGTH		
W152E12-6	TB1	8	I6	CB1	5	16N5	E12-6	76	PHASE C	BLUE
W153E22-92	DS11	1	N2	CB9	1	I2	E22-92	32	28 VDC	WHT/RED
W154E12-9	TB2	8	I6	S4	4	I5	E12-9	40	NEUTRAL	WHITE
W155E12-2	TB2	7	I6	S4	1	I5	E12-2	40	PHASE B	RED
W156E12-9	TB1	3	I6	S4	5	I5	E12-9	47	NEUTRAL	WHITE
W157E22-9	DS10	1	N2	K1	2	I1	E22-9	25	NEUTRAL	WHITE
W158E12-2	S4	2	I5	CB1	3	I6	E12-2	17	PHASE B	RED
W159E22-5	DS11	2	N2	DS9	3	N2	E22-5	32	GROUND	GREEN
W160E22-2	CB1	3	I2	DS10	2	N2	E22-2	29	PHASE B	RED
W161E22-9	DS10	1	N2	DS1	1	N2	E22-9	29	NEUTRAL	WHITE
W162E22-9	TB1	5	I2	PS1	1	I7	E22-9	37	NEUTRAL	WHITE
W163E22-6	TB1	8	I2	PS1	2	I7	E22-6	35	PHASE C	BLUE
W164E22-2	DS10	2	N2	DS10	3	N2	E22-2	4	PHASE B	RED
W165E22-2	DS10	3	N2	DS1	3	N2	E22-2	29	PHASE B	RED
W166E22-2	DS1	3	N2	DS6	3	N2	E22-2	27	PHASE B	RED
W167E22-2	DS6	3	N2	DS7	3	N2	E22-2	18	PHASE B	RED
W168E22-2	DS7	3	N2	DS8	3	N2	E22-2	18	PHASE B	RED

0286N	THIS DOCUMENT HAS BEEN PURCHASED BY THE GOVERNMENT AND MAY BE REPRODUCED AND USED IN CONNECTION WITH ANY GOVERNMENT PROCUREMENT OR MAINTENANCE OPERATION	SIZE	FSCM NO.	DRAWING NO.		
		A	80063	A3093209		
		SCALE	NONE	LTR	F	SHEET 10

WIRE NO. OR COLOR	FROM TERMINATION			TO TERMINATION			WIRE		FUNCTION	REMARKS
	REF DES	PIN	(I) ITEM (N) NOTE	REF DES	PIN	(I) ITEM (N) NOTE	ITEM	LENGTH		
W169E22-0	CB1	1	12	DS4	3	N2	E22-0	24	PHASE A	BLACK
W170E22-0	DS4	3	N2	DS5	3	N2	E22-0	18	PHASE A	BLACK
W171E22-6	CB1	5	12	DS2	3	N2	E22-6	16	PHASE C	BLUE
W172E22-6	DS2	3	N2	DS3	3	N2	E22-6	18	PHASE C	BLUE
W173E22-5	DS11	3	N2	CB9	C	N2	E22-5	32	GROUND	GREEN
W174E22-5	DS11	2	N2	DS11	3	N2	E22-5	4	GROUND	GREEN
W175E14-92	TB1	1	14	PS2	+IN	N2	E14-92	43	144 VDC	WHT/RED
W176E14-90	TB2	2	14	PS2	-IN	N2	E14-90	43	144 RTN	WHT/BLK
W177E18-5	TB2	5	12	PS2	-OUT	N2	E18-5	35	GROUND	GREEN
W410E18-92	CB9	2	12			18 N4 N7	E18-92	23.5	28 VDC	WHT/RED
W411E18-5	TB2	5	12			18 N4 N7	E18-5	22.5	GROUND	GREEN
W412E14-0	CB5	2	14			14 N4 N6	E14-0	16.5	PHASE A	BLACK
W413E14-9	TB1	3	14			14 N4 N6	E14-9	15.8	NEUTRAL	WHITE
W414E14-5	TB2	4	14			14 N4 N6	E14-5	14.5	GROUND	GREEN
W415E14-2	CB6	2	14			14 N4 N7	E14-2	17.0	PHASE B	RED
W416E14-9	TB1	3	14			14 N4 N7	E14-9	16.8	NEUTRAL	WHITE
W417E14-5	TB2	4	14			14 N4 N7	E14-5	16.3	GROUND	GREEN
W418E14-2	CB7	2	14			14 N4 N7	E14-2	26.3	PHASE B	RED

0286N	THIS DOCUMENT HAS BEEN PURCHASED BY THE GOVERNMENT AND MAY BE REPRODUCED AND USED IN CONNECTION WITH ANY GOVERNMENT PROCUREMENT OR MAINTENANCE OPERATION	SIZE	FSCM NO.	DRAWING NO.		
		A	80063	A3093209		
		SCALE	NONE	LTR	F	SHEET 11

WIRE NO. OR COLOR	FROM TERMINATION			TO TERMINATION			WIRE		FUNCTION	REMARKS
	REF DES	PIN	(I) ITEM (N) NOTE	REF DES	PIN	(I) ITEM (N) NOTE	ITEM	LENGTH		
W419E14-9	TB1	4	14			14 N4 N7	E14-9	25.5	NEUTRAL	WHITE
W420E14-5	TB2	5	14			14 N4 N7	E14-5	25.3	GROUND	GREEN
W427E14-2	S2	3	13			110 N4 N7	E14-2	168	PHASE B	RED
W443E14-9	TB1	4	14			14 N4 N7	E14-9	262	NEUTRAL	WHITE
W444E14-5	TB2	6	14			14 N4 N7	E14-5	262	GROUND	GREEN
W445E14-2	S3	2	13			110 N4 N7	E14-2	168	PHASE B	RED
W446E14-2	S3	1	13			14 N4 N7	E14-2	270	PHASE B	RED
W447E14-2	S3	3	13			14 N4 N7	E14-2	270	PHASE B	RED
W453E14-2	S3	1	13			14 N4 N6	E14-2	7.3	PHASE B	RED
W482E14-6	CB2	2	14			14 N4 N7	E14-6	338	PHASE C	BLUE
W483E14-9	TB1	2	14			14 N4 N7	E14-9	338	NEUTRAL	WHITE
W484E14-5	TB2	3	14			14 N4 N7	E14-5	338	GROUND	GREEN
W492E14-0	CB4	2	14			14 N4 N7	E14-0	300	PHASE A	BLACK
W493E14-2	CB4	4	14			14 N4 N7	E14-2	300	PHASE B	RED
W494E14-6	CB4	6	14			14 N4 N7	E14-6	300	PHASE C	BLUE
W495E14-9	TB1	2	14			14 N4 N7	E14-9	300	NEUTRAL	WHITE
W496E14-5	TB2	3	14			14 N4 N7	E14-5	300	GROUND	GREEN

THIS DOCUMENT HAS BEEN PURCHASED BY THE GOVERNMENT AND MAY BE REPRODUCED AND USED IN CONNECTION WITH ANY GOVERNMENT PROCUREMENT OR MAINTENANCE OPERATION	SIZE	FSCM NO.	DRAWING NO.		
	A	80063	A3093209		
	SCALE	NONE	LTR	F	SHEET 12

WIRE NO. OR COLOR	FROM TERMINATION			TO TERMINATION			WIRE		FUNCTION	REMARKS
	REF DES	PIN	(I) ITEM (N) NOTE	REF DES	PIN	(I) ITEM (N) NOTE	ITEM	LENGTH		
W497E14-6	CB3	2	I4			I4 N4 N7	E14-6	316	PHASE C	BLUE
W498E14-9	TB1	2	I4			I4 N4 N7	E14-9	316	NEUTRAL	WHITE
W499E14-5	TB2	3	I4			I4 N4 N7	E14-5	316	GROUND	GREEN
W485E12-5	TB2	6	I6			N4 N6	E12-5	146	GROUND	GREEN
W486E12-9	TB2	8	I6			N4 N6	E12-9	146	NEUTRAL	WHITE
W487E12-2	TB2	7	I6			N4 N6	E12-2	146	PHASE B	RED
W402E14-92	TB1	1	I4	P2	1	N4 N10	E14-92	134	+144 DC	WHITE/RED
W403E14-90	TB2	2	I4	P2	2	N4 N10	E14-90	134	DC COM	WHITE/BLK
W405E12-0	TB1	6	I4	P3	1	N4 N11	E12-0	134	PHASE A	BLACK
W488E12-2	TB1	7	I4	P3	2	N4 N11	E12-2	134	PHASE B	RED
W489E12-6	TB1	8	I4	P3	3	N4 N11	E12-6	134	PHASE C	BLUE
W490E12-9	TB2	1	I4	P3	7	N4 N11	E12-9	134	NEUTRAL	WHITE

0286N	THIS DOCUMENT HAS BEEN PURCHASED BY THE GOVERNMENT AND MAY BE REPRO- DUCED AND USED IN CONNECTION WITH ANY GOVERNMENT PROCUREMENT OR MAINTENANCE OPERATION	SIZE	FSCM NO.	DRAWING NO.	
		A	80063	A3093209	
		SCALE	NONE	LTR	F SHEET 13

A3093209

WIRING LIST, POINT-TO-POINT, POWER DISTRIBUTION PANEL (Sheet 13 of 13)

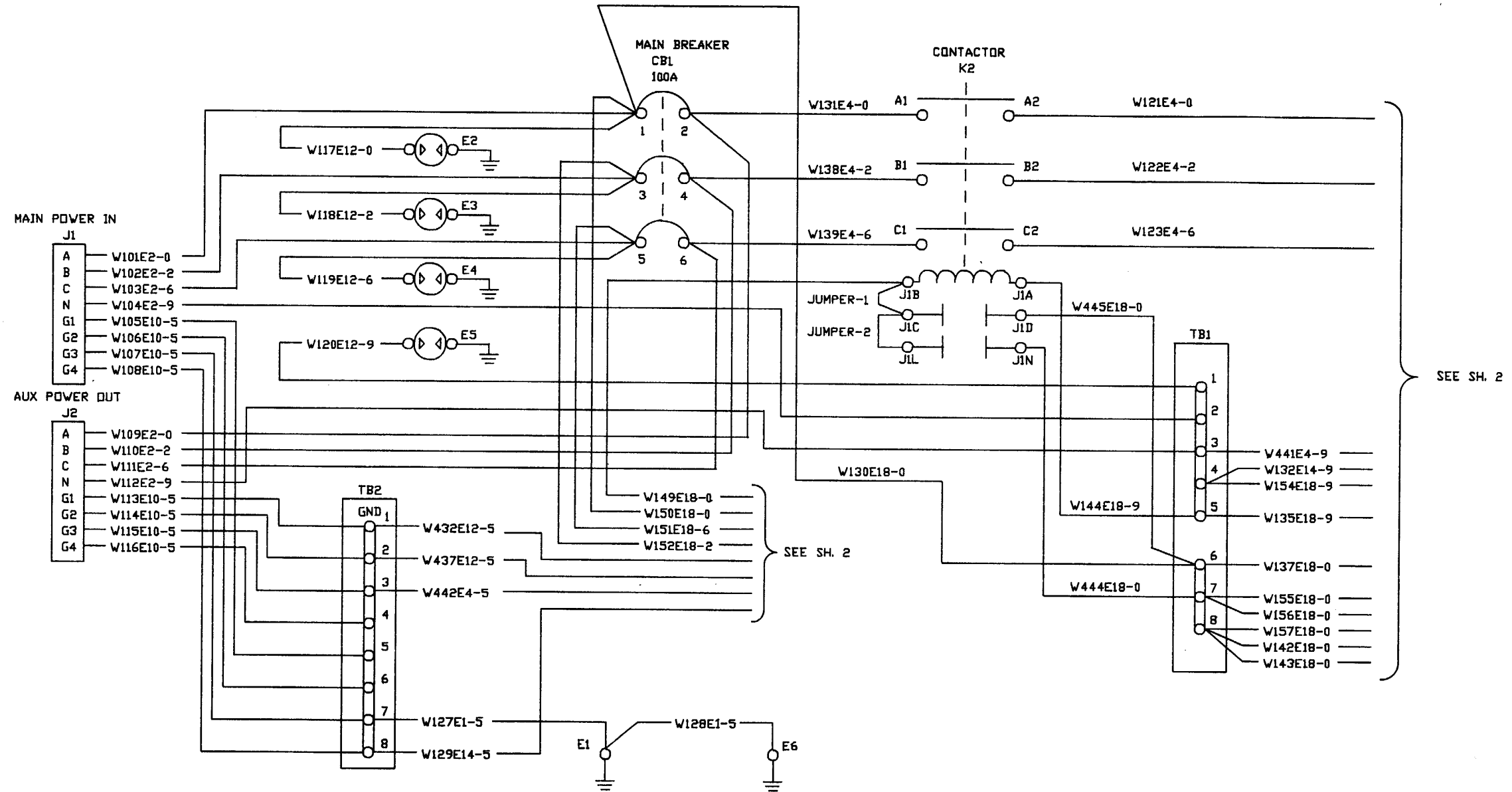

NOTES :

1. PARTIAL REFERENCE DESIGNATIONS ARE SHOWN. FOR COMPLETE REFERENCE DESIGNATION, PREFIX WITH UNIT NUMBER AND SUBASSEMBLY DESIGNATION.

Schematic Diagram, Power Entry (Sheet 1 of 2)

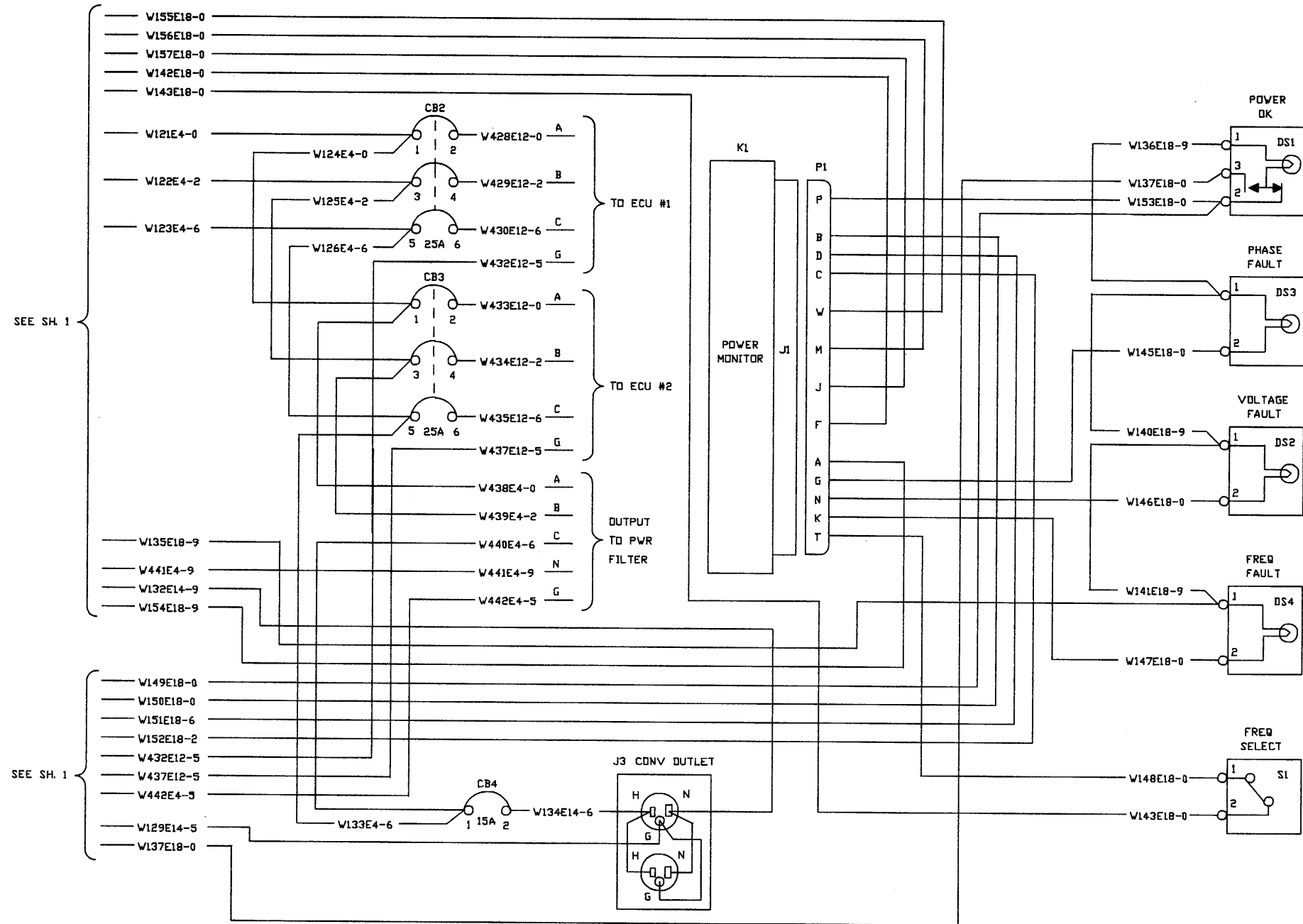

Schematic Diagram, Power Entry (Sheet 2 of 2)

A3093264

NOTE: DATA MARKED WITH AN ASTERISK IS PECULIAR TO A PRIOR MANUFACTURER. IT DOES NOT TAKE PRECEDENCE OVER ANY OTHER DATA ON THIS DRAWING, AND IS NOT CONTRACTUALLY BINDING ON EITHER THE CONTRACTOR OR THE GOVERNMENT.

THIS DOCUMENT HAS BEEN PURCHASED BY THE GOVERNMENT AND MAY BE REPRODUCED AND USED IN CONNECTION WITH ANY GOVERNMENT PROCUREMENT OR MAINTENANCE OPERATION.	REVISIONS																																																
	<table border="1" style="width: 100%; border-collapse: collapse;"> <thead> <tr> <th style="width: 10%;">EFF</th> <th style="width: 10%;">LTR</th> <th style="width: 15%;">NO.</th> <th style="width: 45%;">DESCRIPTION</th> <th style="width: 15%;">DATE</th> <th style="width: 15%;">APPROVED</th> </tr> </thead> <tbody> <tr> <td>ALL</td> <td>A</td> <td></td> <td>INC ECN 89811</td> <td>87-11-04</td> <td>DD <i>CP</i></td> </tr> <tr> <td>ALL</td> <td>B</td> <td></td> <td>INC ECN 94444</td> <td>88-09-19</td> <td>RR <i>CP</i></td> </tr> <tr> <td>ALL</td> <td>C</td> <td></td> <td>INC ECN 93664</td> <td>88-07-20</td> <td>LC <i>SL</i></td> </tr> <tr> <td>ALL</td> <td>D</td> <td></td> <td>INC ECN 101613</td> <td>88-12-22</td> <td>LC <i>CP</i></td> </tr> <tr> <td>ALL</td> <td>E</td> <td></td> <td>INC ECN 113512, ADDITION OF TEXT TO DOCUMENT CHANGED THE SHEET COUNT FROM 11 TO 12.</td> <td>89-06-22</td> <td>AH <i>TBS</i></td> </tr> <tr> <td></td> <td>F</td> <td></td> <td>INC ECN 135738</td> <td>91-03-21</td> <td>LC <i>Z</i></td> </tr> <tr> <td></td> <td>G</td> <td></td> <td>INC ECN 142548</td> <td>92-03-23</td> <td>MD <i>46</i> <i>U/L</i></td> </tr> </tbody> </table>	EFF	LTR	NO.	DESCRIPTION	DATE	APPROVED	ALL	A		INC ECN 89811	87-11-04	DD <i>CP</i>	ALL	B		INC ECN 94444	88-09-19	RR <i>CP</i>	ALL	C		INC ECN 93664	88-07-20	LC <i>SL</i>	ALL	D		INC ECN 101613	88-12-22	LC <i>CP</i>	ALL	E		INC ECN 113512, ADDITION OF TEXT TO DOCUMENT CHANGED THE SHEET COUNT FROM 11 TO 12.	89-06-22	AH <i>TBS</i>		F		INC ECN 135738	91-03-21	LC <i>Z</i>		G		INC ECN 142548	92-03-23	MD <i>46</i> <i>U/L</i>
EFF	LTR	NO.	DESCRIPTION	DATE	APPROVED																																												
ALL	A		INC ECN 89811	87-11-04	DD <i>CP</i>																																												
ALL	B		INC ECN 94444	88-09-19	RR <i>CP</i>																																												
ALL	C		INC ECN 93664	88-07-20	LC <i>SL</i>																																												
ALL	D		INC ECN 101613	88-12-22	LC <i>CP</i>																																												
ALL	E		INC ECN 113512, ADDITION OF TEXT TO DOCUMENT CHANGED THE SHEET COUNT FROM 11 TO 12.	89-06-22	AH <i>TBS</i>																																												
	F		INC ECN 135738	91-03-21	LC <i>Z</i>																																												
	G		INC ECN 142548	92-03-23	MD <i>46</i> <i>U/L</i>																																												

REV	SHEET																		
REV STATUS OF SHEETS	REV SHEET	G	F	B	B	F	F	F	B	B	B	G	F						
		1	2	3	4	5	6	7	8	9	10	11	12						

NOTES: 1. PREPARED IN ACCORDANCE WITH DOD-STD-100. 2. UNLESS OTHERWISE SPECIFIED, DIMENSIONS ARE IN INCHES.	ELECTROSPACE SYSTEMS, INC. DAAB07-86-C-J00B	U.S. ARMY COMMUNICATIONS — ELECTRONIC COMMAND FORT MONMOUTH, NEW JERSEY 07703																				
	<table border="1" style="width: 100%; border-collapse: collapse;"> <tr> <td style="width: 15%;">APVD</td> <td style="width: 15%;">D. MORUE</td> <td style="width: 15%;">MM</td> <td style="width: 15%;">87-10-12</td> </tr> <tr> <td>ENGR</td> <td>D. PLEMONS</td> <td>DP</td> <td>87-10-06</td> </tr> <tr> <td>ENGR</td> <td>C. PYBUS</td> <td>CP</td> <td>87-10-06</td> </tr> <tr> <td>CHECK</td> <td>C. REID</td> <td>CR</td> <td>87-10-12</td> </tr> <tr> <td>DRAWN</td> <td>L. CHATEL</td> <td>LC</td> <td>87-10-06</td> </tr> </table>	APVD	D. MORUE	MM	87-10-12	ENGR	D. PLEMONS	DP	87-10-06	ENGR	C. PYBUS	CP	87-10-06	CHECK	C. REID	CR	87-10-12	DRAWN	L. CHATEL	LC	87-10-06	DRAWING TITLE WIRING LIST, POINT-TO-POINT, POWER ENTRY
APVD	D. MORUE	MM	87-10-12																			
ENGR	D. PLEMONS	DP	87-10-06																			
ENGR	C. PYBUS	CP	87-10-06																			
CHECK	C. REID	CR	87-10-12																			
DRAWN	L. CHATEL	LC	87-10-06																			
A3093251 NEXT ASSY USED ON	DLA3093251 DATE	<table border="1" style="width: 100%; border-collapse: collapse;"> <tr> <td style="width: 15%;">SIZE</td> <td style="width: 15%;">FSCM NO.</td> <td style="width: 70%;">DRAWING NO.</td> </tr> <tr> <td style="text-align: center;">A</td> <td style="text-align: center;">80063</td> <td style="text-align: center;">A3093267</td> </tr> </table>	SIZE	FSCM NO.	DRAWING NO.	A	80063	A3093267														
SIZE	FSCM NO.	DRAWING NO.																				
A	80063	A3093267																				
APPLICATION		<table border="1" style="width: 100%; border-collapse: collapse;"> <tr> <td style="width: 15%;">SCALE</td> <td style="width: 15%;">NONE</td> <td style="width: 15%;">G</td> <td style="width: 55%;">SHEET 1 OF 12</td> </tr> </table>	SCALE	NONE	G	SHEET 1 OF 12																
SCALE	NONE	G	SHEET 1 OF 12																			

NOTES:

1. REFERENCE SCHEMATIC DIAGRAM A3093264.
2. SOLDER SHALL BE IN ACCORDANCE WITH MIL-STD-454, REQUIREMENT 5.
3. RING LUG TERMINALS ARE CRIMPED USING MS23002 DIES WITH MS25441 TOOL FOR WIRES SIZE 8 THRU 4/0. LUGS ARE CRIMPED USING MIL-C-22520/5-01 TOOLING WITH MIL-C-22520/5-100 DIES INSTALLED FOR WIRE SIZES 26 THRU 10, OR MIL-C-22520/10-01 TOOLING WITH MIL-C-22520/10-101 DIES INSTALLED FOR WIRE SIZES 26 THRU 14 AND MIL-C-22520/10-100 DIES INSTALLED FOR WIRE SIZES 12 THRU 10.
4. THIS END NOT CONNECTED. WIRES W428-W430, W432-W435 AND W437 ARE ROUTED OUT THE SMALL CONDUIT OPENING LOCATED ON THE BOTTOM OF THE ENCLOSURE. WIRES W438-W442 ARE ROUTED OUT THE LARGE CONDUIT OPENING LOCATED ON THE BOTTOM OF THE ENCLOSURE. WIRE LENGTH IS MEASURED FROM THE APPROPRIATE ENCLOSURE OPENING TO THE UNCONNECTED END.
5. P1 IS ITEM 18 OF PARTS LIST. USE M22520/1-01 TOOL WITH M22520/1-02 TURRET. INSERTION TOOL IS M81969/17-04. EXTRACTION TOOL IS M81969/19-08. AFTER ALL TERMINATIONS ARE MADE TO P1 CONNECT P1 TO J1 OF POWER MONITOR K1. REF MIL-C-22520 AND MIL-I-81969.
6. CRIMP PINS FOR WIRE SIZE 2 WITH PICO MODEL 400B TOOL WITH 4297-3 LOCATOR AND 414DA-1/ON DIE. REMOVAL TOOL IS MS90562-3. CRIMP PINS FOR WIRE SIZE 10 WITH PICO MODEL 400B TOOL WITH 4297-6 LOCATOR AND 414DA-6N DIE. REMOVAL TOOL IS MS90562-6.
7. SPLICE WIRES TO J3 USING ITEM 23 OF PARTS LIST.
8. THIS NOTE INTENTIONALLY LEFT BLANK.
9. SOLDER WIRE END TO P2 (ITEM 25). AFTER W144 AND W149 ARE TERMINATED TO P2 CONNECT TO CONTACTOR (K2).
10. WIRE LENGTHS ARE GIVEN IN INCHES. TOLERANCE IS ±2.0 INCHES.

THIS DOCUMENT HAS BEEN PURCHASED BY THE GOVERNMENT AND MAY BE REPRODUCED AND USED IN CONNECTION WITH ANY GOVERNMENT PROCUREMENT OR MAINTENANCE OPERATION	SIZE A	FSCM NO. 80063	DRAWING NO. A3093267
	SCALE	NONE	LTR F SHEET 2

A3093267

WIRING LIST, POINT-TO-POINT, POWER ENTRY (Sheets 1 & 2 of 12)

NOTES (CONT):

11. TYPE APPROPRIATE "W" NUMBER ON TWO 1 1/2 INCH LENGTHS OF SHRINKABLE SLEEVING FOR EACH WIRE. SHRINK SLEEVING APPROXIMATELY 2 INCHES FROM EACH END. USE ITEM 20 FOR 18 AWG, ITEM 21 FOR 14-10 AWG AND ITEM 24 FOR 4-1 AWG.
12. SEE FIGURES 1 AND 2 FOR CIRCUIT BREAKER TERMINAL DESIGNATIONS.

0280N	THIS DOCUMENT HAS BEEN PURCHASED BY THE GOVERNMENT AND MAY BE REPRODUCED AND USED IN CONNECTION WITH ANY GOVERNMENT PROCUREMENT OR MAINTENANCE OPERATION	SIZE	FSCM NO.	DRAWING NO.	
		A	80063	A3093267	
		SCALE	NONE	LTR	B SHEET 9

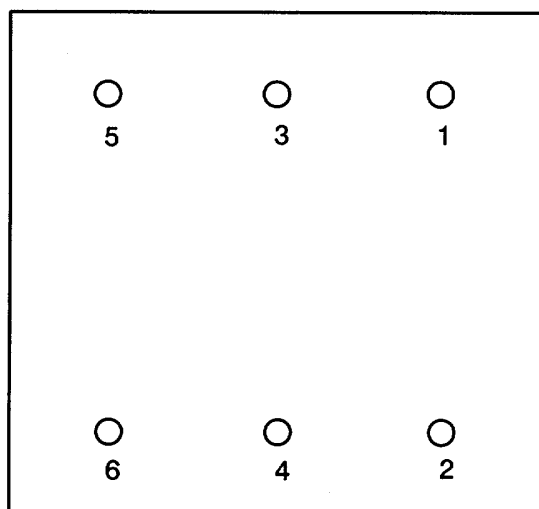

(TERMINAL SIDE VIEW)

FIGURE 1. 3-POLE CIRCUIT BREAKER TERMINAL CONFIGURATION.

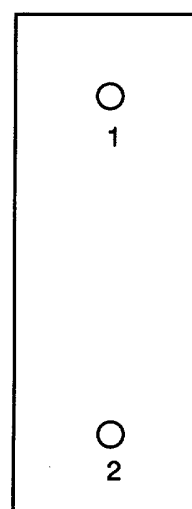

(TERMINAL SIDE VIEW)

FIGURE 2. SINGLE POLE BREAKER TERMINAL CONFIGURATION.

	THIS DOCUMENT HAS BEEN PURCHASED BY THE GOVERNMENT AND MAY BE REPRODUCED AND USED IN CONNECTION WITH ANY GOVERNMENT PROCUREMENT OR MAINTENANCE OPERATION	SIZE	FSCM NO.	DRAWING NO.	
		A	80063	A3093267	
		SCALE	NONE	LTR	B SHEET 4

A3093267

PARTS LIST					
QTY	ITEM	PART NO.	DESCRIPTION	SPEC/STD	FSCM NO.
12	1	MS25036-105	TERMINAL LUG, RING, 3/8, 22-18 AWG		96906
1	2	MS25036-108	TERMINAL LUG, RING, NO. 10, 16-14 AWG		
2	3	MS25036-110	TERMINAL LUG, RING, 3/8, 16-14 AWG		
6	4	MS25036-112	TERMINAL LUG, RING, NO. 10, 12-10 AWG		
4	5	MS25036-113	TERMINAL LUG, RING, 5/16, 12-10 AWG		
11	6	MS25036-114	TERMINAL LUG, RING, 3/8, 12-10 AWG		
9	7	MS25036-123	TERMINAL LUG, RING, 1/4, 4 AWG		
8	8	MS25036-125	TERMINAL LUG, RING, 3/8, 4 AWG		
6	9	MS25036-126	TERMINAL LUG, RING, 1/4, 2 AWG		
2	10	MS25036-127	TERMINAL LUG, RING, 3/8, 2 AWG		
1	11	MS25036-130	TERMINAL LUG, RING, 3/8, 1 AWG		
3	12	MS25036-134	TERMINAL LUG, RING, 1/2, 1/0 AWG		
1	13	MS25036-149	TERMINAL LUG, RING, NO. 8, 22-18 AWG		
4	14	MS25036-150	TERMINAL LUG, RING, 1/4, 22-18 AWG		
3	15	MS25036-157	TERMINAL LUG, RING, 1/4, 12-10 AWG		
4	16	MS25171-2S-TB	BOOT, INSULATING		
2	17	MS25036-102	TERMINAL LUG, RING NO. 6, 22-18 AWG		
1	18	MS3126E-22-21S	CONNECTOR, CIRCULAR (P1)		

0280N	THIS DOCUMENT HAS BEEN PURCHASED BY THE GOVERNMENT AND MAY BE REPRODUCED AND USED IN CONNECTION WITH ANY GOVERNMENT PROCUREMENT OR MAINTENANCE OPERATION	SIZE	FSCM NO.	DRAWING NO.	
		A	80063	A3093267	
		SCALE	NONE	LTR	F SHEET 5

PARTS LIST					
QTY	ITEM	PART NO.	DESCRIPTION	SPEC/STD	FSCM NO.
	19				
64	20	M23053/5-104-9	HEAT SHRINKABLE SLEEVING	(IN) MIL-I-23053/5	81349
70	21	M23053/5-105-9	HEAT SHRINKABLE SLEEVING	(IN) MIL-I-23053/5	81349
	22				
3	23	M7928/3-3	WIRE SPLICE, CRIMP	MIL-T-7928/3	81349
63	24	M23053/5-108-9	HEAT SHRINKABLE SLEEVING	(IN) MIL-I-23053/5	81349
1	25	MS3106R20-29S	CONNECTOR, CIRCULAR (P2)		96906
AR	E1-5	M16878/12BTR5	WIRE, 1 AWG, GREEN	MIL-W-16878/12	81349
AR	E2-0	M16878/12BSP0	WIRE, 2 AWG, BLACK	MIL-W-16878/12	81349
AR	E2-2	M16878/12BSP2	WIRE, 2 AWG, RED	MIL-W-16878/12	81349
AR	E2-6	M16878/12BSP6	WIRE, 2 AWG, BLUE	MIL-W-16878/12	81349
AR	E2-9	M16878/12BSP9	WIRE, 2 AWG, WHITE	MIL-W-16878/12	81349
AR	E4-0	M16878/12BRL0	WIRE, 4 AWG, BLACK	MIL-W-16878/12	81349
AR	E4-2	M16878/12BRL2	WIRE, 4 AWG, RED	MIL-W-16878/12	81349
AR	E4-5	M16878/12BRL5	WIRE, 4 AWG, GREEN	MIL-W-16878/12	81349
AR	E4-6	M16878/12BRL6	WIRE, 4 AWG, BLUE	MIL-W-16878/12	81349
AR	E4-9	M16878/12BRL9	WIRE, 4 AWG, WHITE	MIL-W-16878/12	81349

THIS DOCUMENT HAS BEEN PURCHASED BY THE GOVERNMENT AND MAY BE REPRODUCED AND USED IN CONNECTION WITH ANY GOVERNMENT PROCUREMENT OR MAINTENANCE OPERATION	SIZE	FSCM NO.	DRAWING NO.	
	A	80063	A3093267	
		SCALE	NONE	LTR F SHEET 6

A3093267

WIRING LIST, POINT-TO-POINT, POWER ENTRY, (Sheets 5 & 6 of 12)

PARTS LIST					
QTY	ITEM	PART NO.	DESCRIPTION	SPEC/STD	FSCM NO.
AR	E10-5	M16878/4BMG5	WIRE, 10 AWG, GREEN	MIL-W-16878/4	81349 ↓
AR	E12-0	M16878/4BLE0	WIRE, 12 AWG, BLACK	MIL-W-16878/4	
AR	E12-2	M16878/4BLE2	WIRE, 12 AWG, RED	MIL-W-16878/4	
AR	E12-5	M16878/4BLE5	WIRE, 12 AWG, GREEN	MIL-W-16878/4	
AR	E12-6	M16878/4BLE6	WIRE, 12 AWG, BLUE	MIL-W-16878/4	
AR	E12-9	M16878/4BLE9	WIRE, 12 AWG, WHITE	MIL-W-16878/4	
AR	E14-5	M16878/4BKE5	WIRE, 14 AWG, GREEN	MIL-W-16878/4	
AR	E14-6	M16878/4BKE6	WIRE, 14 AWG, BLUE	MIL-W-16878/4	
AR	E14-9	M16878/4BKE9	WIRE, 14 AWG, WHITE	MIL-W-16878/4	
AR	E18-0	M16878/4BHE0	WIRE, 18 AWG, BLACK	MIL-W-16878/4	
AR	E18-2	M16878/4BHE2	WIRE, 18 AWG, RED	MIL-W-16878/4	
AR	E18-6	M16878/4BHE6	WIRE, 18 AWG, BLUE	MIL-W-16878/4	
AR	E18-9	M16878/4BHE9	WIRE, 18 AWG, WHITE	MIL-W-16878/4	
AR	E24-0	M16878/4BEE0	WIRE, 24 AWG, BLACK	MIL-W-16878/4	

0280N	THIS DOCUMENT HAS BEEN PURCHASED BY THE GOVERNMENT AND MAY BE REPRODUCED AND USED IN CONNECTION WITH ANY GOVERNMENT PROCUREMENT OR MAINTENANCE OPERATION	SIZE A	FSCM NO. 80063	DRAWING NO. A3093267
		SCALE NONE	LTR F	SHEET 7

WIRE NO. OR COLOR	FROM TERMINATION			TO TERMINATION			WIRE		FUNCTION	REMARKS
	REF DES	PIN	(I) ITEM (N) NOTE	REF DES	PIN	(I) ITEM (N) NOTE	ITEM	LENGTH		
W101E2-0	J1	A	N6	CB1	1	19	E2-0	36	PHASE A	BLACK
W102E2-2	J1	B	N6	CB1	3	19	E2-2	36	PHASE B	RED
W103E2-6	J1	C	N6	CB1	5	19	E2-6	36	PHASE C	BLUE
W104E2-9	J1	N	N6	TB1	2	110	E2-9	48	NEUTRAL	WHITE
W105E10-5	J1	G1	N6	TB2	5	16	E10-5	48	GROUND	GREEN
W106E10-5	J1	G2	N6	TB2	6	16	E10-5	48	GROUND	GREEN
W107E10-5	J1	G3	N6	TB2	7	16	E10-5	48	GROUND	GREEN
W108E10-5	J1	G4	N6	TB2	8	16	E10-5	48	GROUND	GREEN
W109E2-0	J2	A	N6	CB1	2	19	E2-0	36	PHASE A	BLACK
W110E2-2	J2	B	N6	CB1	4	19	E2-2	36	PHASE B	RED
W111E2-6	J2	C	N6	CB1	6	19	E2-6	36	PHASE C	BLUE
W112E2-9	J2	N	N6	TB1	3	110	E2-9	48	NEUTRAL	WHITE
W113E10-5	J2	G1	N6	TB2	1	16	E10-5	48	GROUND	GREEN
W114E10-5	J2	G2	N6	TB2	2	16	E10-5	48	GROUND	GREEN
W115E10-5	J2	G3	N6	TB2	3	16	E10-5	48	GROUND	GREEN
W116E10-5	J2	G4	N6	TB2	4	16	E10-5	48	GROUND	GREEN
W117E12-0	CB1	1	115	E2		15I16	E12-0	48	PHASE A	BLACK
W118E12-2	CB1	3	115	E3		15I16	E12-2	48	PHASE B	RED

THIS DOCUMENT HAS BEEN PURCHASED BY THE GOVERNMENT AND MAY BE REPRODUCED AND USED IN CONNECTION WITH ANY GOVERNMENT PROCUREMENT OR MAINTENANCE OPERATION	SIZE A	FSCM NO. 80063	DRAWING NO. A3093267
	SCALE NONE	LTR B	SHEET 8

A3093267

WIRING LIST, POINT-TO-POINT, POWER ENTRY (Sheets 7 & 8 of 12)

WIRE NO. OR COLOR	FROM TERMINATION			TO TERMINATION			WIRE		FUNCTION	REMARKS
	REF DES	PIN	(I) ITEM (N) NOTE	REF DES	PIN	(I) ITEM (N) NOTE	ITEM	LENGTH		
W119E12-6	CB1	5	I15	E4		I5I16	E12-6	48	PHASE C	BLUE
W120E12-9	TB1	1	I6	E5		I5I16	E12-9	48	NEUTRAL	WHITE
W121E4-0	K2	A2	I8	CB2	5	I7	E4-0	48	PHASE A	BLACK
W122E4-2	K2	B2	I8	CB2	3	I7	E4-2	48	PHASE B	RED
W1 23E4-6	K2	C2	I8	CB2	1	I7	E4-6	48	PHASE C	BLUE
W127E1-5		E6	I12	TB2	7	I11	E1-5	30	GROUND	GREEN
W128E1-5		E1	I12	E7		I12	E1-5	20	GROUND	GREEN
W129E14-5	TB2	8	I3	J3	G	N7	E14-5	48	GROUND	GREEN
W130E18-0	CB1	1	I14	TB1	6	I1	E18-0	48	PHASE A	BLACK
W131E4-0	CB1	2	I7	K2	AI	I8	E4-0	48	PHASE A	BLACK
W132E14-9	TB1	4	I3	J3	W	N7	E14-9	48	NEUTRAL	WHITE
W134E14-6	CB4	2	I2	J3	B	N7	E14-6	8	PHASE C	BLUE
W135E18-9	TB1	5	I1	DS4	1	N2	E18-9	36	NEUTRAL	WHITE
W136E18-9	DS1	1	N2	DS3	1	N2	E18-9	12	NEUTRAL	WHITE
W137E18-0	TB1	6	I1	DS1	3	N2	E18-0	36	PHASE A	BLACK
W138E4-2	CB1	4	I7	K2	B1	I8	E4-2	48	PHASE B	RED

0280N	THIS DOCUMENT HAS BEEN PURCHASED BY THE GOVERNMENT AND MAY BE REPRODUCED AND USED IN CONNECTION WITH ANY GOVERNMENT PROCUREMENT OR MAINTENANCE OPERATION	SIZE	FSCM NO.	DRAWING NO.
		A	80063	A3093267
		SCALE	NONE	LTR B SHEET 9

WIRE NO. OR COLOR	FROM TERMINATION			TO TERMINATION			WIRE		FUNCTION	REMARKS
	REF DES	PIN	(I) ITEM (N) NOTE	REF DES	PIN	(I) ITEM (N) NOTE	ITEM	LENGTH		
W139E4-6	CB1	6	I7	K2	C1	I18	E4-6	48	PHASE C	BLUE
W140E18-9	DS3	1	N2	DS2	1	N2	E18-9	72	NEUTRAL	WHITE
W141 E18-9	DS2	1	N2	DS4	1	N2	E18-9	72	NEUTRAL	WHITE
W142E18-0	TB1	8	I1	P1	F	N5	E18-0	48	PHASE A	BLACK
W143E18-0	TB1	8	I1	S1	2	I17	E18-0	48	PHASE A	BLACK
W144E18-9	P2	A	N9	TB1	5	I1	E18-9	48	NEUTRAL	WHITE
W145E18-0	DS3	2	N2	P1	G	N5	E18-0	36	PHASE A	BLACK
W146E18-0	DS2	2	N2	P1	N	N5	E18-0	36	PHASE A	BLACK
W147E18-0	DS4	2	N2	P1	K	N5	E18-0	36	PHASE A	BLACK
W148E18-0	S1	1	I17	P1	T	N5	E18-0	36	PHASE A	BLACK
W149E18-0	P2	B	N9	DS1	2	N2	E18-0	36	PHASE A	BLACK
W150E18-0	CB1	1	I14	P1	B	N5	E18-0	48	PHASE A	BLACK
W151E18-6	CB1	5	I14	P1	D	N5	E18-6	48	PHASE C	BLUE
W152E18-2	CB1	3	I14	P1	C	N5	E18-2	48	PHASE B	RED
W153E18-0	DS1	2	N2	P1	P	N5	E18-0	36	PHASE A	BLACK
W154E18-9	TB1	4	I1	P1	A	N5	E18-9	36	NEUTRAL	WHITE

0280N	THIS DOCUMENT HAS BEEN PURCHASED BY THE GOVERNMENT AND MAY BE REPRODUCED AND USED IN CONNECTION WITH ANY GOVERNMENT PROCUREMENT OR MAINTENANCE OPERATION	SIZE	FSCM NO.	DRAWING NO.
		A	80063	A3093267
		SCALE	NONE	LTR B SHEET 10

WIRE NO. OR COLOR	FROM TERMINATION			TO TERMINATION			WIRE		FUNCTION	REMARKS	
	REF DES	PIN	(I) ITEM (N) NOTE	REF DES	PIN	(I) ITEM (N) NOTE	ITEM	LENGTH			
W155E18-0	TB1	7		I1	P1	W	N5	E18-0	36	PHASE A	BLACK
W156E18-0	TB1	7		I1	P1	M	N5	E18-0	36	PHASE A	BLACK
W157E18-0	TB1	8		I1	P1	J	N5	E18-0	36	PHASE A	BLACK
W428E12-0	CB2	6		I4			N4	E12-0	260	PHASE A	BLACK
W429E12-2	CB2	4		I4			N4	E12-2	260	PHASE B	RED
W430E12-6	CB2	2		I4			N4	E12-6	260	PHASE C	BLUE
W432E12-5	TB2	1		I6			N4	E12-5	260	GROUND	GREEN
W433E12-0	CB3	6		I4			N4	E12-0	300	PHASE A	BLACK
W434E12-2	CB3	4		I4			N4	E12-2	300	PHASE B	RED
W435E12-6	CB3	2		I4			N4	E12-6	300	PHASE C	BLUE
W437E12-5	TB2	2		I6			N4	E12-5	300	GROUND	GREEN
W438E4-0	CB3	1		I7			N4	E4-0	32	PHASE A	BLACK
W439E4-2	CB3	3		I7			N4	E4-2	35	PHASE B	RED
W440E4-6	CB4	1		I7			N4	E4-6	38	PHASE C	BLUE
W441 E4-9	TB1	3		I8			N4	E4-9	41	NEUTRAL	WHITE
W442E4-5	TB2	3		I8			N4	E4-5	34	GROUND	GREEN
W444E18-0	P2	N			TB1	7	I1	E18-0	44	PHASE A	BLACK

0280N	THIS DOCUMENT HAS BEEN PURCHASED BY THE GOVERNMENT AND MAY BE REPRODUCED AND USED IN CONNECTION WITH ANY GOVERNMENT PROCUREMENT OR MAINTENANCE OPERATION	SIZE	FSCM NO.	DRAWING NO.
		A	80063	A3093267
		SCALE	NONE	LTR G SHEET 11

WIRE NO. OR COLOR	FROM TERMINATION			TO TERMINATION			WIRE		FUNCTION	REMARKS	
	REF DES	PIN	(I) ITEM (N) NOTE	REF DES	PIN	(I) ITEM (N) NOTE	ITEM	LENGTH			
W445E18-0	P2	D		TB1	6		I1	E18-0	44	PHASE A	BLACK
JUMPER-1	P2	B		P2	C			E24-0	4	PHASE A	BLACK
JUMPER-2	P2	C		P2	L			E24-0	4	PHASE A	BLACK

	THIS DOCUMENT HAS BEEN PURCHASED BY THE GOVERNMENT AND MAY BE REPRODUCED AND USED IN CONNECTION WITH ANY GOVERNMENT PROCUREMENT OR MAINTENANCE OPERATION	SIZE	FSCM NO.	DRAWING NO.
		A	80063	A3093267
		SCALE	NONE	LTR F SHEET 12

WIRING LIST,
POINT-TO-POINT,
POWER ENTRY
(Sheets 11 & 12 of 12)

NOTE: DATA MARKED WITH AN ASTERISK (*) IS PECULIAR TO A PRIOR MANUFACTURER.
IT DOES NOT TAKE PRECEDENCE OVER ANY OTHER DATA ON THIS DRAWING, AND IS NOT CONTRACTUALLY BINDING ON EITHER THE CONTRACTOR OR THE GOVERNMENT.

THIS DOCUMENT HAS BEEN PURCHASED BY THE GOVERNMENT AND MAY BE REPRODUCED AND USED IN CONNECTION WITH ANY GOVERNMENT PROCUREMENT OR MAINTENANCE OPERATION.

REVISIONS					
EFF	LTR	NO.	DESCRIPTION	DATE	APPROVED
ALL	A		INC ECN 89012	88-03-08	RR
	B		INC ECN 108557, EFF: 89-05-16		AH
	C		INC ECN 135004	90-10-15	LC

REV SHEET	REV SHEET	C	A	C	A															
		1	2	3	4															

1. PREPARED IN ACCORDANCE WITH DOD-STD-100. 2. UNLESS OTHERWISE SPECIFIED, DIMENSIONS ARE IN INCHES.		ELECTROSPACE SYSTEMS, INC. DAAB07-86-C-J008		U.S. ARMY COMMUNICATIONS— ELECTRONIC COMMAND FORT MONMOUTH, NEW JERSEY 07703	
		APVD	D. MORUE	87-10-03	DRAWING TITLE WIRING LIST, POINT-TO-POINT, LIGHT FIXTURE
		ENGR	D. PLEMONS	87-10-01	
		ENGR	C. PYBUS	87-10-01	
		CHECK	C. REID	87-10-03	
A3093315	DLA3092692	DRAWN	L. CHAFFIN	87-10-01	
A3093315	DLA3092951	REV			
A3093315	DLA3092801	APVD			
A3093315	DLA3092651	DATE			
NEXT ASSY	USED ON	SCALE	NONE		DRAWING NO. A3093320
APPLICATION		SIZE	A		FSCM NO. 80063
		SCALE	NONE		LTR A SHEET 1 OF 4

NOTES:

- REFERENCE SCHEMATIC DIAGRAM A3093314.
- RING LUG TERMINALS ARE CRIMPED USING MIL-C-22520/5-01 TOOLING WITH MIL-C-22520/5-100 DIE.
- WIRES RT1W008 THROUGH RT1W015 ARE PART OF BALLAST. THE BALLAST END OF EACH OF THESE WIRES IS ALREADY INTERNALLY CONNECTED TO THE BALLAST. TACK SOLDER WIRES TO TERMINAL LUG AFTER CRIMPING.
- TYPE APPROPRIATE WIRE NUMBER (WXXX) ON ITEM 1 AND HEAT SHRINK OVER EACH WIRE APPROXIMATELY 2 INCHES FROM EACH END. CUT ITEM 1 INTO 1 1/2 INCH LENGTHS.
- WIRES W006E18-4 AND W007E18-4, USE EXCESS YELLOW WIRE FROM BALLAST FOR JUMPERS FROM XDS3B TO XDS4B.

THIS DOCUMENT HAS BEEN PURCHASED BY THE GOVERNMENT AND MAY BE REPRODUCED AND USED IN CONNECTION WITH ANY GOVERNMENT PROCUREMENT OR MAINTENANCE OPERATION	SIZE	FSCM NO.	DRAWING NO.
	A	80063	A3093320
SCALE		LTR	SHEET
NONE		A	2

PARTS LIST					
QTY	ITEM	PART NO.	DESCRIPTION	SPEC/STD	FSCM NO.
30	1	TMS-1/2 X 1.50-9	HEAT SHRINKABLE WIRE MARKER	MIL-I-23053	81349
10	2	MS25036-102	TERMINAL LUG, RING, NO. 6, 22-18 AWG		96906
2	3	MS25036-103	TERMINAL LUG, RING, NO. 10, 22-18 AWG		96906
4	4	MS25036-107	TERMINAL LUG, RING, NO. 6, 16-14 AWG		96906
5	5	MS25036-108	TERMINAL LUG, RING, NO. 10, 16-14 AWG		96906
1	6	MS25036-153	TERMINAL LUG, RING, NO. 8, 16-14 AWG		96906
AR	E16-0	M16878/4BJE0	WIRE, 16 AWG, BLACK	MIL-W-16878/4	81349
AR	E16-5	M16878/4BJE5	WIRE, 16 AWG, GREEN	MIL-W-16878/4	81349
AR	E16-9	M16878/4BJE9	WIRE, 16 AWG, WHITE	MIL-W-16878/4	81349
AR	E18-4	M16878/4BHE4	WIRE, 18 AWG, YELLOW	MIL-W-16878/4	81349

THIS DOCUMENT HAS BEEN PURCHASED BY THE GOVERNMENT AND MAY BE REPRODUCED AND USED IN CONNECTION WITH ANY GOVERNMENT PROCUREMENT OR MAINTENANCE OPERATION	SIZE	FSCM NO.	DRAWING NO.
	A	80063	A3093320
SCALE	NONE	LTR	C SHEET 3

WIRE NO. OR COLOR	FROM TERMINATION			TO TERMINATION			WIRE		FUNCTION	REMARKS
	REF DES	PIN	(I) ITEM (N) NOTE	REF DES	PIN	(I) ITEM (N) NOTE	ITEM	LENGTH		
W002E16-0	XDS1	C	I4	TB1	1	I5	E16-0		HOT	FXTR CENTER TERM
W002E16-0	XDS2	C	I4	TB1	3	I5	E16-0		HOT	FXTR CENTER TERM
W003E16-9	XDS1	0	I4	TB1	4	I5	E16-9		NEUTRAL	FXTR OUTER TERM
W004E16-9	XDS2	0	I4	TB1	4	I5	E16-9		NEUTRAL	FXTR OUTER TERM
W005E16-5	E1		I5	TB1	5	I5	E16-5		GROUND	
W006E18-4	XDS3B	2	I2, N5	XDS4B	2	I4, N5			BLST NEUT	YELLOW
W007E18-4	XDS3B	1	I2, N5	XDS4B	1	I4, N5			BLST NEUT	YELLOW
RT1W008		N3	XDS4B		2	I2			BLST NEUT	YELLOW
RT1W009		N3	XDS4B		1	I2			BLST NEUT	YELLOW
RT1W010		N3	TB1		2	I5			HOT	BLACK
RT1W011		N3	TB1		4	I5			NEUTRAL	WHITE
RT1W012		N3	XDS3A		2	I2			BLST HOT	RED
RT1W013		N3	XDS3A		1	I2			BLST HOT	RED
RT1W014		N3	XDS4A		2	I2			BLST HOT	BLUE
RT1W015		N3	XDS4A		1	I2			BLST HOT	BLUE

THIS DOCUMENT HAS BEEN PURCHASED BY THE GOVERNMENT AND MAY BE REPRODUCED AND USED IN CONNECTION WITH ANY GOVERNMENT PROCUREMENT OR MAINTENANCE OPERATION	SIZE	FSCM NO.	DRAWING NO.
	A	80063	A3093320
SCALE	NONE	LTR	A SHEET 4

NOTES :

- 1. PARTIAL REFERENCE DESIGNATION ARE SHOWN. FOR COMPLETE REFERENCE DESIGNATION, PREFIX WITH UNIT NUMBER AND SUB ASSEMBLY DESIGNATION.

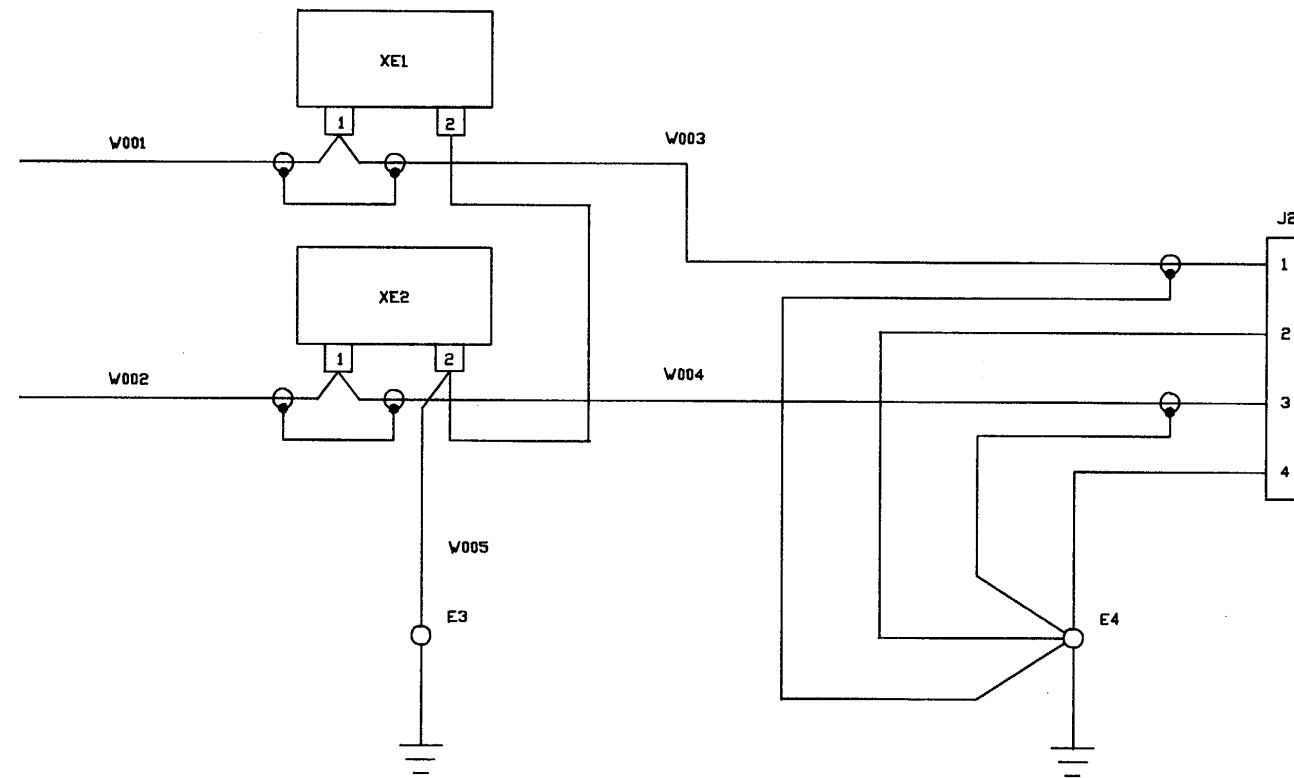

Schematic Diagram, Group Data

NOTE: DATA MARKED WITH AN ASTERISK (*) PECULIAR TO A PRIOR MANUFACTURER.
IT DOES NOT TAKE PRECEDENCE OVER ANY OTHER DATA ON THIS DRAWING, AND IS NOT CONTRACTUALLY BINDING ON EITHER THE CONTRACTOR OR THE GOVERNMENT.

THIS DOCUMENT HAS BEEN PURCHASED BY THE GOVERNMENT AND MAY BE REPRODUCED AND USED IN CONNECTION WITH ANY GOVERNMENT PROCUREMENT OR MAINTENANCE OPERATION.

REVISIONS					
EFF	LTR	NO.	DESCRIPTION	DATE	APPROVED
ALL	A		INC ECN 89492	88-05-30	RR <i>[Signature]</i>
	B		INC ECN 135530	91-03-20	LC

REV SHEET																				
REV STATUS OF SHEETS	REV SHEET	B	A	A	B	A														
1. PREPARED IN ACCORDANCE WITH DOD-STD-100.		ELECTROSPACE SYSTEMS, INC.					U.S. ARMY COMMUNICATIONS - ELECTRONIC COMMAND FORT MONMOUTH, NEW JERSEY 07703													
2. UNLESS OTHERWISE SPECIFIED, DIMENSIONS ARE IN INCHES.		APVD	D. MORUE	<i>[Signature]</i>	87/9/8	DRAWING TITLE														
		ENGR	D. PLEMONS	<i>[Signature]</i>	87-8-31	WIRING LIST, POINT-TO-POINT, GROUP DATA														
		ENGR	C. PYBUS	<i>[Signature]</i>	87-8-31															
		CHECK	C. REID	<i>[Signature]</i>	87-9-8															
A3093363	DLA3092951	DRAWN	L. CHATELAIN	<i>[Signature]</i>	87-8-31	SIZE	FSCM NO.	DRAWING NO.												
A3093363	DLA3092801	REV				A	80063	A3093366												
A3093363	DLA3092651	APVD																		
NEXT ASSY	USED ON	DATE																		
APPLICATION		SCALE	NONE	B	SHEET 1 OF 5															

NOTES:

- REFERENCE SCHEMATIC A3093365.
- USE CRIMP TOOL MIL-C-22520/5-01 WITH MIL-C-22520/5-100 DIE.
- LEAVE THIS END UNTERMINATED.
- THIS NOTE INTENTIONALLY LEFT BLANK.
- THIS NOTE INTENTIONALLY LEFT BLANK.
- THIS NOTE INTENTIONALLY LEFT BLANK.
- TERMINATED LEADS FROM (J2-1 SHLD) AND (J2-2) IN ANY HOLE AT E4 CLOSEST TO PIN OF (J2-2).
- UNSHIELDED PORTION OF WHITE CONDUCTORS TERMINATING AT J2 AND UNSHIELDED PORTION OF CENTER CONDUCTORS TERMINATING AT XE1 -1, XE2-1 NOT TO RUN PARALLEL FOR A DISTANCE GREATER THAN 1/4 INCH.
- LEAD TO E3 TO BE AS SHORT AS POSSIBLE.
- TERMINATE LEADS FROM (J2-3 SHLD) AND (J2-4) IN ANY HOLE AT E4 CLOSEST TO PIN (J2-4).
- THIS NOTE INTENTIONALLY LEFT BLANK.
- SOLDER PER MIL-STD-454, REQUIREMENT 5.
- MIL-STD-454, REQUIREMENT 9 SHALL BE COMPLIED WITH.
- SEE FIGURE 2.
- SEE FIGURE 1.
- SHRINK ONE INCH LENGTH OF ITEM 11 MARKED "W001" APPROXIMATELY 5 INCHES FROM UNTERMINATED END.
- SHRINK ONE INCH LENGTH OF ITEM 11 MARKED "W002" APPROXIMATELY 5 INCHES FROM UNTERMINATED

THIS DOCUMENT HAS BEEN PURCHASED BY THE GOVERNMENT AND MAY BE REPRODUCED AND USED IN CONNECTION WITH ANY GOVERNMENT PROCUREMENT OR MAINTENANCE OPERATION	SIZE	FSCM NO.	DRAWING NO.
	A	80063	A3093366
SCALE		NONE	LTR A SHEET 2

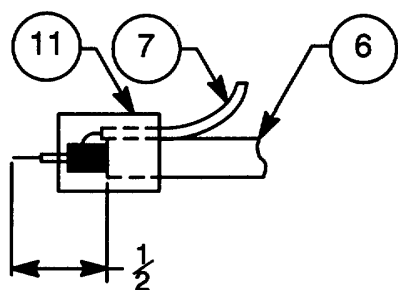

FIGURE 1

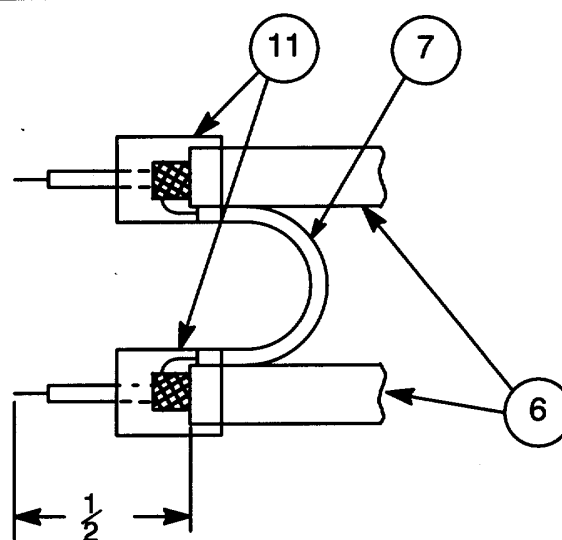

FIGURE 2

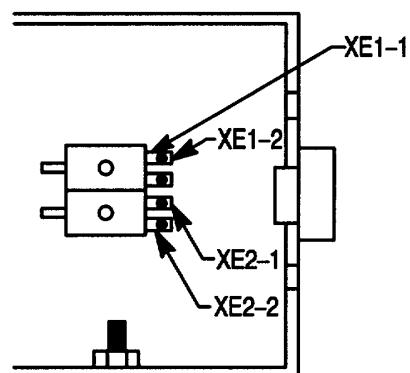

FIGURE 4

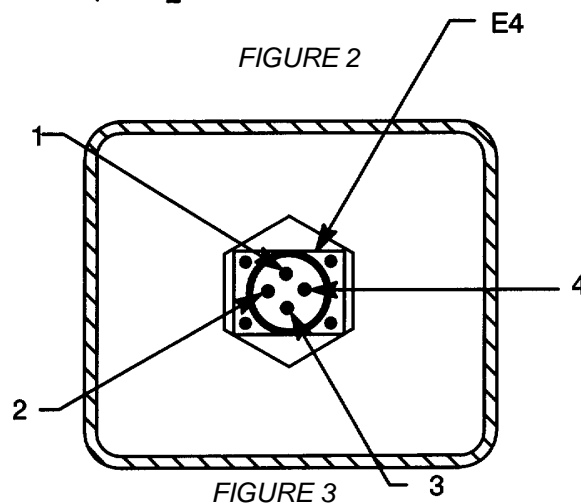

FIGURE 3

THIS DOCUMENT HAS BEEN PURCHASED BY THE GOVERNMENT AND MAY BE REPRODUCED AND USED IN CONNECTION WITH ANY GOVERNMENT PROCUREMENT OR MAINTENANCE OPERATION

SIZE FSCM NO.
A 80063

DRAWING NO.
A3093207

SCALE NONE LTR A SHEET 3

PARTS LIST

QTY	ITEM	PART NO.	DESCRIPTION	SPEC/STD	FSCM NO.
1	11	MS25036-149	TERMINAL LUG	MIL-T-7928	81349
AR	2	SN60WRMAP2	SOLDER, TIN ALLOY	QQ-S-571	81348
3					
4					
5					
2	6	M17/119-RG174	CABLE, RF, COAX, LF	MIL-C-17/119	81349
8	7	M16878/12BFE0	WIRE, 22 AWG, BLACK	(IN) MIL-W-16878/12	81349
1	8	M23053/5-106-9	HEAT SHRINK, SLEEVING, 1/4 DIA	(IN) MIL-I-23053/5	81349
9					
1	10	M23053/5-105-9	HEAT SHRINK SLEEVING, 3/16 DIA	(IN) MIL-I-23053/5	81349
4	11	M23053/5-104-9	HEAT SHRINK SLEEVING, 1/8 DIA	(IN) MIL-I-23053/5	81349

THIS DOCUMENT HAS BEEN PURCHASED BY THE GOVERNMENT AND MAY BE REPRODUCED AND USED IN CONNECTION WITH ANY GOVERNMENT PROCUREMENT OR MAINTENANCE OPERATION

SIZE FSCM NO.
A 80063

DRAWING NO.
A3093366

SCALE NONE LTR B SHEET 4

WIRING LIST,
POINT-TO-POINT,
GROUP DATA
(Sheets 3 & 4 of 5)

WIRE NO. OR COLOR	FROM TERMINATION			TO TERMINATION			WIRE		FUNCTION	REMARKS
	REF DES	PIN	(I) ITEM (N) NOTE	REF DES	PIN	(I) ITEM (N) NOTE	ITEM	LENGTH		
JMPR	XE1 (SHLD) W001	1	N14	XE1(SHLD) W003	1	N14	I7	3 IN		SHLDS OF W001, W003 ARE CONNECTED
W001	XE1	1	18, N8	NONE		N3, N16	I6	8 IN		
W003	J2 J2-1(SHLD)	1	N8, N15 I11 E4	XE1 1 17	1	N7, N8	I6	6 IN 2 IN		
JMPR	J2	2		E4		N7	I7	2 IN		
JMPR	XE2(SHLD) W002	1	N14	XE2(SHLD) W004	1	N14	I7	3 IN		SHLDS OF W002, W004 ARE CONNECTED
W002	NONE		N3, N17	XE2	1	I8, N8	I6	8 IN		
W004	J2 J2-3(SHLD)	3	N8, N15 I11	XE2 E4	1	N8, N10	I6	6 IN		
JMPR	J2	4		E4		N10	I7	2 IN		
JMPR	XE1	2	I10	XE2	2	I10	I7	1 IN		
W005	E3		I1, N2, N9	XE2	2	N6	I7			

0274N	THIS DOCUMENT HAS BEEN PURCHASED BY THE GOVERNMENT AND MAY BE REPRO- DUCED AND USED IN CONNECTION WITH ANY GOVERNMENT PROCUREMENT OR MAINTENANCE OPERATION	SIZE	FSCM NO.	DRAWING NO.
		A	80063	A3093366
		SCALE	NONE	LTR A SHEET 5

A3093366

WIRING LIST, POINT-TO-POINT, GROUP DATA
(Sheet 5 of 5)

NOTES :

1. PARTIAL REFERENCE DESIGNATION ARE SHOWN.
FOR COMPLETE REFERENCE DESIGNATION,
PREFIX WITH UNIT NUMBER AND SUB ASSEMBLY
DESIGNATION.

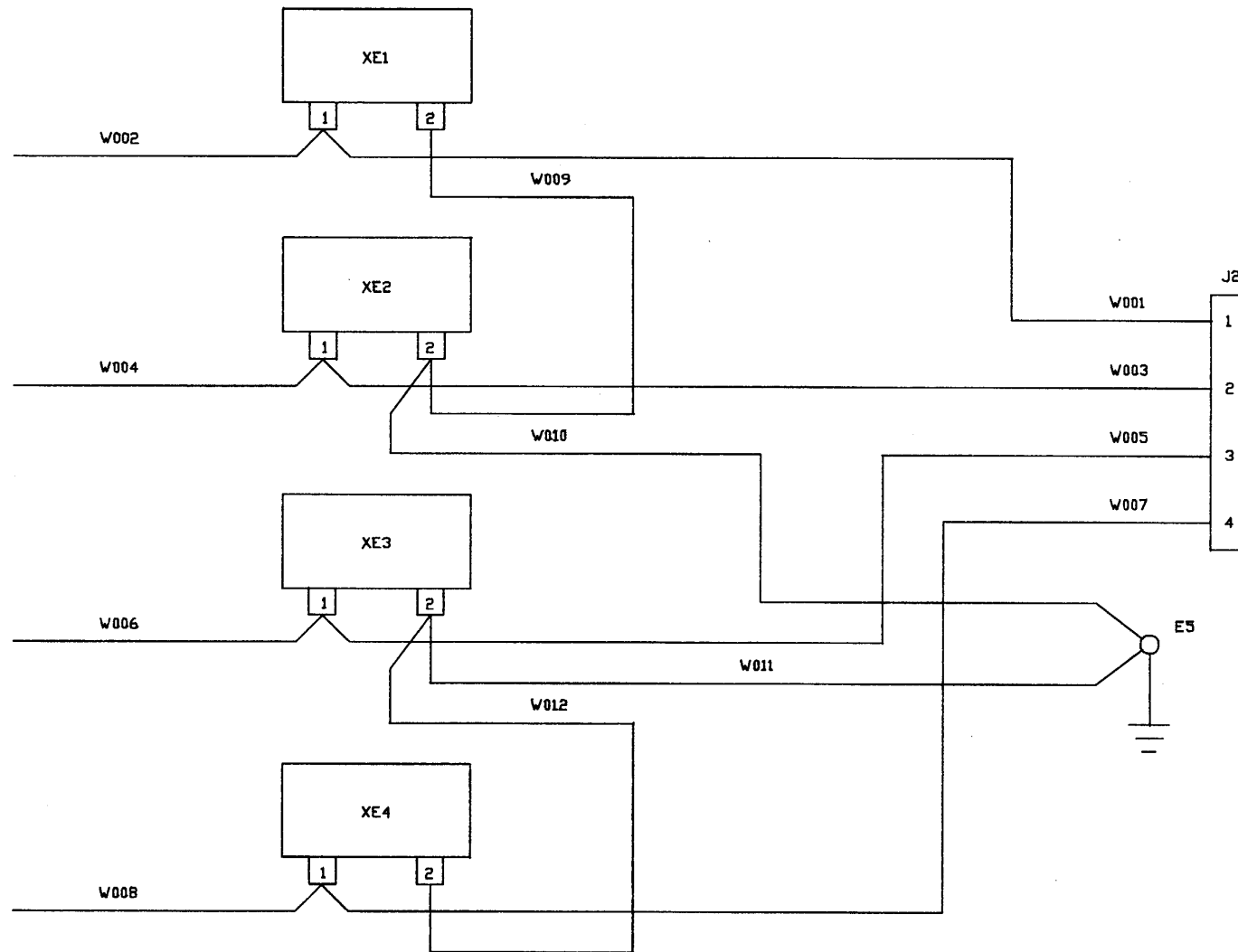

Schematic Diagram, Audio

NOTE: DATA MARKED WITH AN ASTERISK IS PECULIAR TO A PRIOR MANUFACTURER.
IT DOES NOT TAKE PRECEDENCE OVER ANY OTHER DATA ON THIS DRAWING, AND IS NOT CONTRACTUALLY BINDING ON EITHER THE CONTRACTOR OR THE GOVERNMENT.

THIS DOCUMENT HAS BEEN PURCHASED BY THE GOVERNMENT AND MAY BE REPRODUCED AND USED IN CONNECTION WITH ANY GOVERNMENT PROCUREMENT OR MAINTENANCE OPERATION.

REVISIONS					
EFF	LTR	NO.	DESCRIPTION	DATE	APPROVED
ALL	A		INC ECN 94266	88-07-17	RR <i>CP</i>
ALL	B		INC ECN 99312	89-02-22	DD <i>TB</i>
	C		INC ECN 135529	91-03-21	LC <i>Z</i>

REV SHEET																							
REV STATUS OF SHEETS	REV SHEET	C	A	-	C	A																	
		1	2	3	4	5																	

1. PREPARED IN ACCORDANCE WITH DOD-STD-100. 2. UNLESS OTHERWISE SPECIFIED, DIMENSIONS ARE IN INCHES.		ELECTROSPACE SYSTEMS, INC. DAAB07-86-C-J008			U.S. ARMY COMMUNICATIONS - ELECTRONIC COMMAND FORT MONMOUTH, NEW JERSEY 07703					
		APVD	D. MORUE	<i>HLM</i>	<i>87-09-11</i>	DRAWING TITLE				
		ENGR	D. PLEMONS	<i>DF</i>	<i>87-08-31</i>	WIRING LIST, POINT-TO-POINT, AUDIO				
		ENGR	C. PYBUS	<i>CP</i>	<i>87-08-31</i>					
A3093364	DLA3092692	CHECK	C. REID	<i>AD</i>	<i>87-09-11</i>					
A3093364	DLA3092951	DRAWN	L. CHATELAIN	<i>L</i>	<i>87-08-31</i>					
A3093364	DLA3092801	REV					SIZE	FSCM NO.	DRAWING NO.	
A3093364	DLA3092651	APVD					A	80063	A3093368	
NEXT ASSY	USED ON	DATE					SCALE	NONE	C	SHEET 1 OF 5

- NOTES:
1. REFERENCE SCHEMATIC A3093367.
 2. USE CRIMP TOOL MIL-C-22520/5-01 WITH MIL-C-22520/5-100 DIE.
 3. LEAVE THIS END UNTERMINATED.
 4. STRIP LEADS 1/8 INCH. SEE DETAIL A FOR J2 PIN LOCATIONS.
 5. STRIP LEADS 3/16 INCH.
 6. STRIP LEADS 1/4 INCH.
 7. LEAD TO E5 TO BE AS SHORT AS POSSIBLE.
 8. ITEM NO. 2 TO BE CUT INTO 3/4 INCH LENGTHS.
 9. SOLDERING SHALL BE IN ACCORDANCE WITH MIL-STD-454, REQUIREMENT 5.
 10. WORKMANSHIP SHALL BE IN ACCORDANCE WITH MIL-STD-454, REQUIREMENT 9.
 11. SHRINK ONE INCH LENGTH OF ITEM 6 MARKED "W002" APPROXIMATELY FIVE INCHES FROM UNTERMINATED END.
 12. SHRINK ONE INCH LENGTH OF ITEM 6 MARKED "W004" APPROXIMATELY FIVE INCHES FROM UNTERMINATED END.
 13. SHRINK ONE INCH LENGTH OF ITEM 6 MARKED "W006" APPROXIMATELY FIVE INCHES FROM UNTERMINATED END.
 14. SHRINK ONE INCH LENGTH OF ITEM 6 MARKED "W008" APPROXIMATELY FIVE INCHES FROM UNTERMINATED END.
 15. REFERENCE A3093364 FOR COMPONENT LOCATIONS.

THIS DOCUMENT HAS BEEN PURCHASED BY THE GOVERNMENT AND MAY BE REPRODUCED AND USED IN CONNECTION WITH ANY GOVERNMENT PROCUREMENT OR MAINTENANCE OPERATION	SIZE	FSCM NO.	DRAWING NO.
	A	80063	A3093368
SCALE		NONE	LTR A SHEET 2

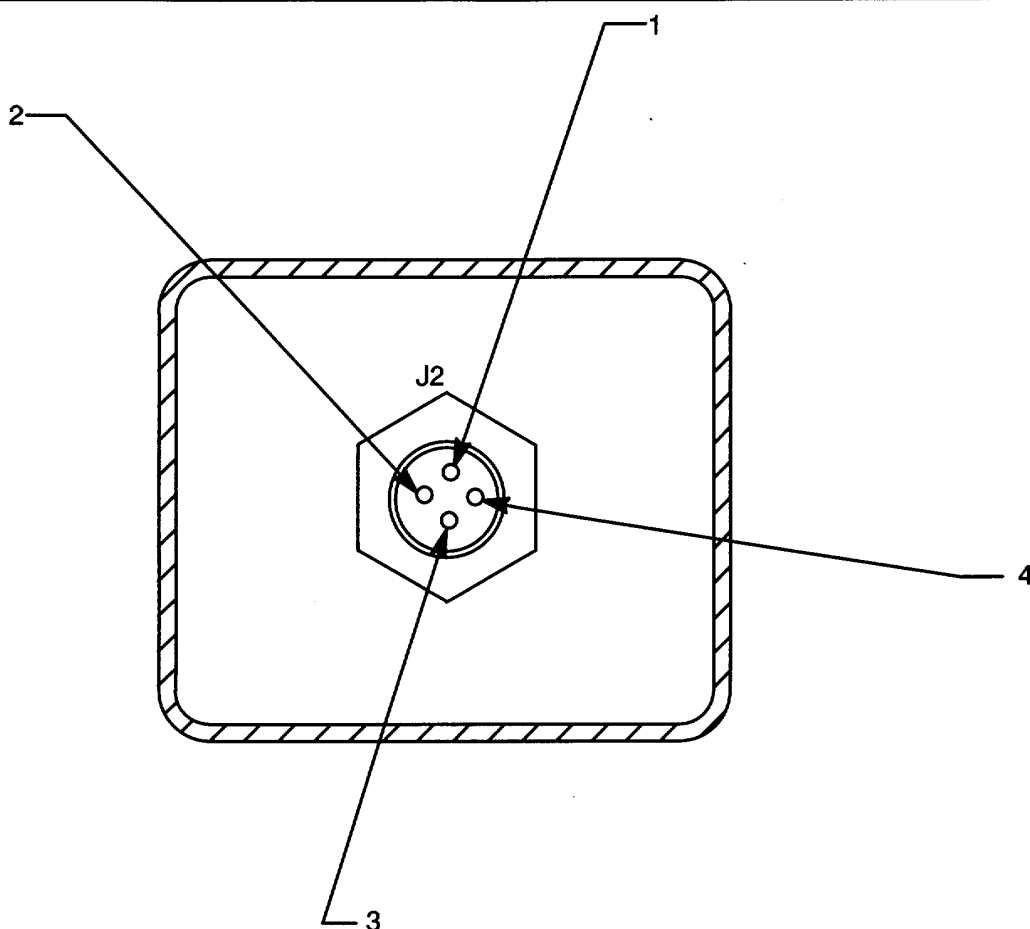

DETAIL A
PIN LOCATIONS

THIS DOCUMENT HAS BEEN PURCHASED BY THE GOVERNMENT AND MAY BE REPRODUCED AND USED IN CONNECTION WITH ANY GOVERNMENT PROCUREMENT OR MAINTENANCE OPERATION	SIZE A	FSCM NO. 80063	DRAWING NO. A3093368	
	SCALE	NONE	LTR	SHEET 3

PARTS LIST

QTY	ITEM	PART NO.	DESCRIPTION	SPEC/STD	FSCM NO.
2	1	MS25036-149	TERMINAL LUG		96906
10	2	M23053/5-106-9	HEAT SHRINK SLEEVING	(IN)	MIL-I-23053/5 81349
AR	3	SN60WRMAP2	SOLDER, TIN ALLOY		QQ-S-571
64	4	M16878/12BFE9	WIRE, 22 AWG, WHITE	(IN)	MIL-W-16878/12
12	5	M16878/12BFEO	WIRE, 22 AWG, BLACK	(IN)	MIL-W-16878/12
4	6	M23053/5-103-9	HEAT SHRINK SLEEVING	(IN)	MIL-I-23053/5

THIS DOCUMENT HAS BEEN PURCHASED BY THE GOVERNMENT AND MAY BE REPRODUCED AND USED IN CONNECTION WITH ANY GOVERNMENT PROCUREMENT OR MAINTENANCE OPERATION	SIZE A	FSCM NO. 80063	DRAWING NO. A3093368	
	SCALE	NONE	LTR	C SHEET 4

WIRING LIST,
POINT-TO-POINT,
AUDIO
(Sheets 3 & 4 of 5)

WIRE NO. OR COLOR	FROM TERMINATION			TO TERMINATION			WIRE		FUNCTION	REMARKS
	REF DES	PIN	(I) ITEM (N) NOTE	REF DES	PIN	(I) ITEM (N) NOTE	ITEM	LENGTH		
W001	J2	1	12, N4, N8	XE1	1	12, N6, N8	14	8 IN		
W002	NONE		N3, N11	XE1	1	12, N6, N8	14	8 IN		
W003	J2	2	12, N4, N8	XE2	1	12, N6, N8	14	8 IN		
W004	NONE		N3, N12	XE2	1	12, N6, N8	14	8 IN		
W005	J2	3	12, N4, N8	XE3	1	12, N6, N8	14	8 IN		
W006	NONE		N3, N13	XE3	1	12, N6, N8	14	8 IN		
W007	J2	4	12, N4, N8	XE4	1	12, N6, N8	14	8 IN		
W008	NONE		N3, N14	XE4	1	12, N6, N8	14	8 IN		
W009	XE1	2	12, N6, N8	XE2	2	12, N6, N8	15	3 IN		
W010	XE2	2	12, N6, N8	E5		11, 12, N2N5N7	15	3 IN		
W011	XE3	2	12, N6, N8	E5		11, 12, N2N5N7	15	3 IN.		
W012	XE3	2	12, N6, N8	XE4	2	12, N6, N8	15	3 IN		

0273N	THIS DOCUMENT HAS BEEN PURCHASED BY THE GOVERNMENT AND MAY BE REPRODUCED AND USED IN CONNECTION WITH ANY GOVERNMENT PROCUREMENT OR MAINTENANCE OPERATION	SIZE	FSCM NO.	DRAWING NO.	
		A	80063	A3093368	
		SCALE	NONE	LTR	A SHEET 5

NOTE: DATA MARKED WITH AN ASTERISK IS PECULIAR TO A PRIOR MANUFACTURER.
IT DOES NOT TAKE PRECEDENCE OVER ANY OTHER DATA ON THIS DRAWING AND
IS NOT CONTRACTUALLY BINDING ON EITHER THE CONTRACTOR OR THE GOVERNMENT.

THIS DOCUMENT HAS BEEN PURCHASED BY THE GOVERNMENT AND MAY BE REPRODUCED AND USED IN CONNECTION WITH ANY GOVERNMENT PROCUREMENT OR MAINTENANCE OPERATION.

EFF	LTR	NO.	DESCRIPTION	DATE	APPROVED
ALL	E		REPLACES REV D WITH CHANGE PER ECN 100405, DELETION OF TEXT FROM DOCUMENT CHANGED THE SHEET COUNT FROM 8 TO 7	89 02	DD TB
ALL	F		INC ECN 102640	-22	AB
	G		INC ECN 137741	91-03-21	LC 7

REV SHEET	REV	G	E	F	C	E	E	E											
		1	2	3	4	5	6	7											

NOTES: 1. PREPARED IN ACCORDANCE WITH DOD-STD-100. 2. UNLESS OTHERWISE SPECIFIED, DIMENSIONS ARE IN INCHES.		ELECTROSPACE SYSTEMS, INC. DAAB07-86-C-J008			U.S. ARMY COMMUNICATIONS - ELECTRONIC COMMAND FORT MONMOUTH, NEW JERSEY 07703				
		APVD	MARTIN	DRAWING TITLE CABLE SET, FIBER OPTIC ETHERNET REPEATER ASSEMBLY					
		ENGR	PYBUS						
		ENGR	vonADELUNG						
		CHECK	FETZER						
		DRAWN	CHATELAIN						
SEE SHEET	2	REV		SIZE	FSCM NO.	DRAWING NO.			
		APVD		A	80063	A3093476			
NEXT ASSY	USED ON	DATE		SCALE	NONE	G	SHEET 1 OF 7		
APPLICATION									

DASH NO.	NEXT ASSEMBLY	USED ON	QTY	DASH NO.	NEXT ASSEMBLY	USED ON	QTY
2	A3092780	DLA30927801					
3	A3092780	DLA30927801					
4	A3092780	DLA30927801					

THIS DOCUMENT HAS BEEN PURCHASED BY THE GOVERNMENT AND MAY BE REPRODUCED AND USED IN CONNECTION WITH ANY GOVERNMENT PROCUREMENT OR MAINTENANCE OPERATION	SIZE	FSCM NO.	DRAWING NO.	
	A	80063	A3093476	
SCALE		NONE	LTR	E SHEET 2

NOTES:

1. UNLESS OTHERWISE SPECIFIED, TOLERANCES ARE: 2 PLACE DECIMALS ± .25.
2. WORKMANSHIP SHALL BE IN ACCORDANCE WITH MIL-STD-454, REQUIREMENT 9.
3. DIMENSIONAL DATA IS BASED ON AMERICAN NATIONAL STANDARD ANSI Y14.5-1973.
4. MARK PER A3092959, DECAL FABRICATION.
5. PARTIAL REFERENCE DESIGNATIONS ARE SHOWN. FOR COMPLETE REFERENCE DESIGNATION, PREFIX WITH UNIT NUMBER AND SUBASSEMBLY DESIGNATION.
6. INTERCONNECTION DIAGRAM IS A3092862.
7. COMPLETE PART NUMBER SHALL INCLUDE APPLICABLE DASH NUMBER.
8. CABLE MARKERS MAY BE APPLIED TO CABLES SUCH THAT MARKERS READ EITHER AWAY FROM CABLE END OR TOWARDS CABLE END.

0440N	THIS DOCUMENT HAS BEEN PURCHASED BY THE GOVERNMENT AND MAY BE REPRODUCED AND USED IN CONNECTION WITH ANY GOVERNMENT PROCUREMENT OR MAINTENANCE OPERATION	SIZE	FSCM NO.	DRAWING NO.		
		A	80063	A3093476		
		SCALE	NONE	LTR	F	SHEET
						3

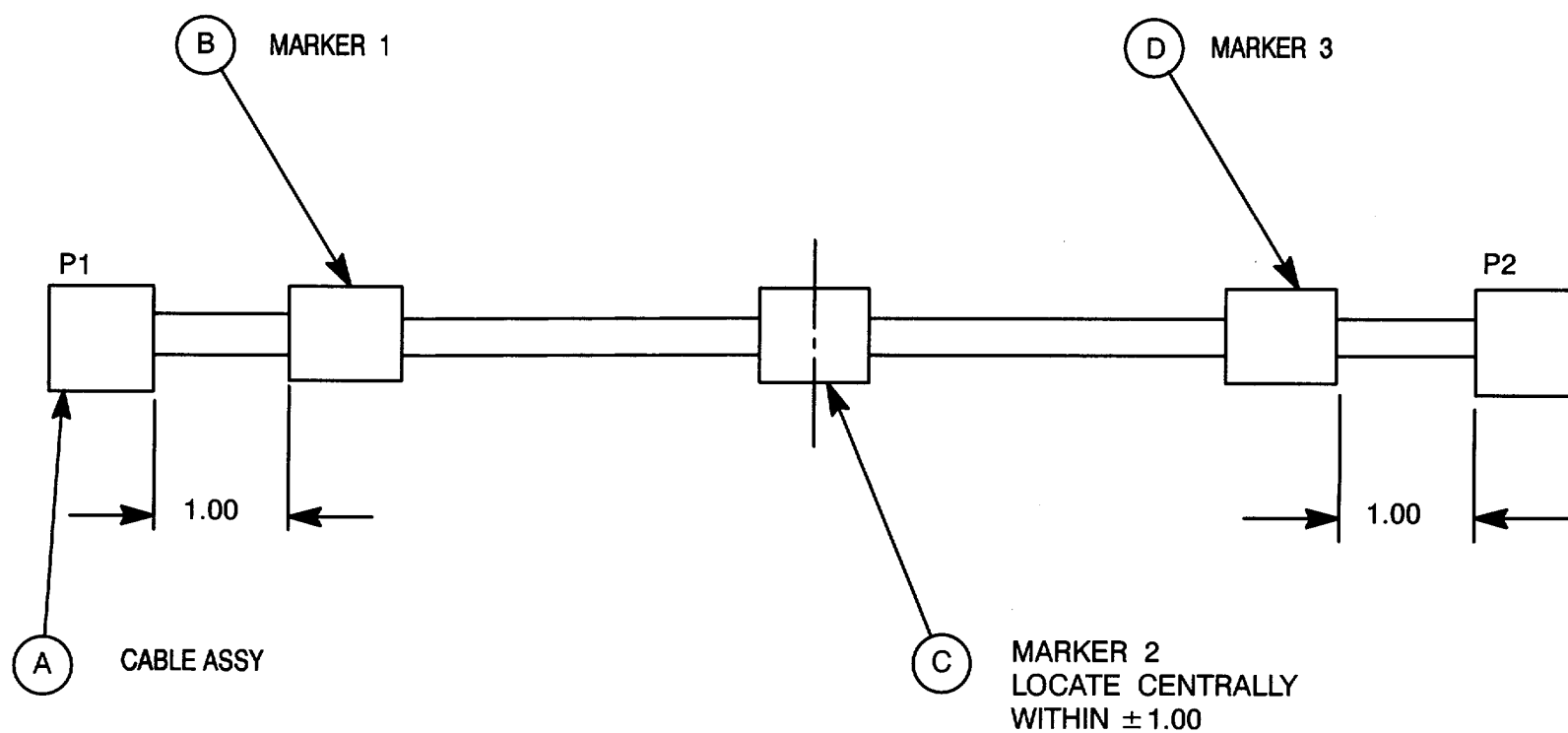

FIGURE 1

THIS DOCUMENT HAS BEEN PURCHASED BY THE GOVERNMENT AND MAY BE REPRODUCED AND USED IN CONNECTION WITH ANY GOVERNMENT PROCUREMENT OR MAINTENANCE OPERATION	SIZE	FSCM NO.	DRAWING NO.			
	A	80063	A3093476			
		SCALE	NONE	LTR	C	SHEET
						4

A3093476

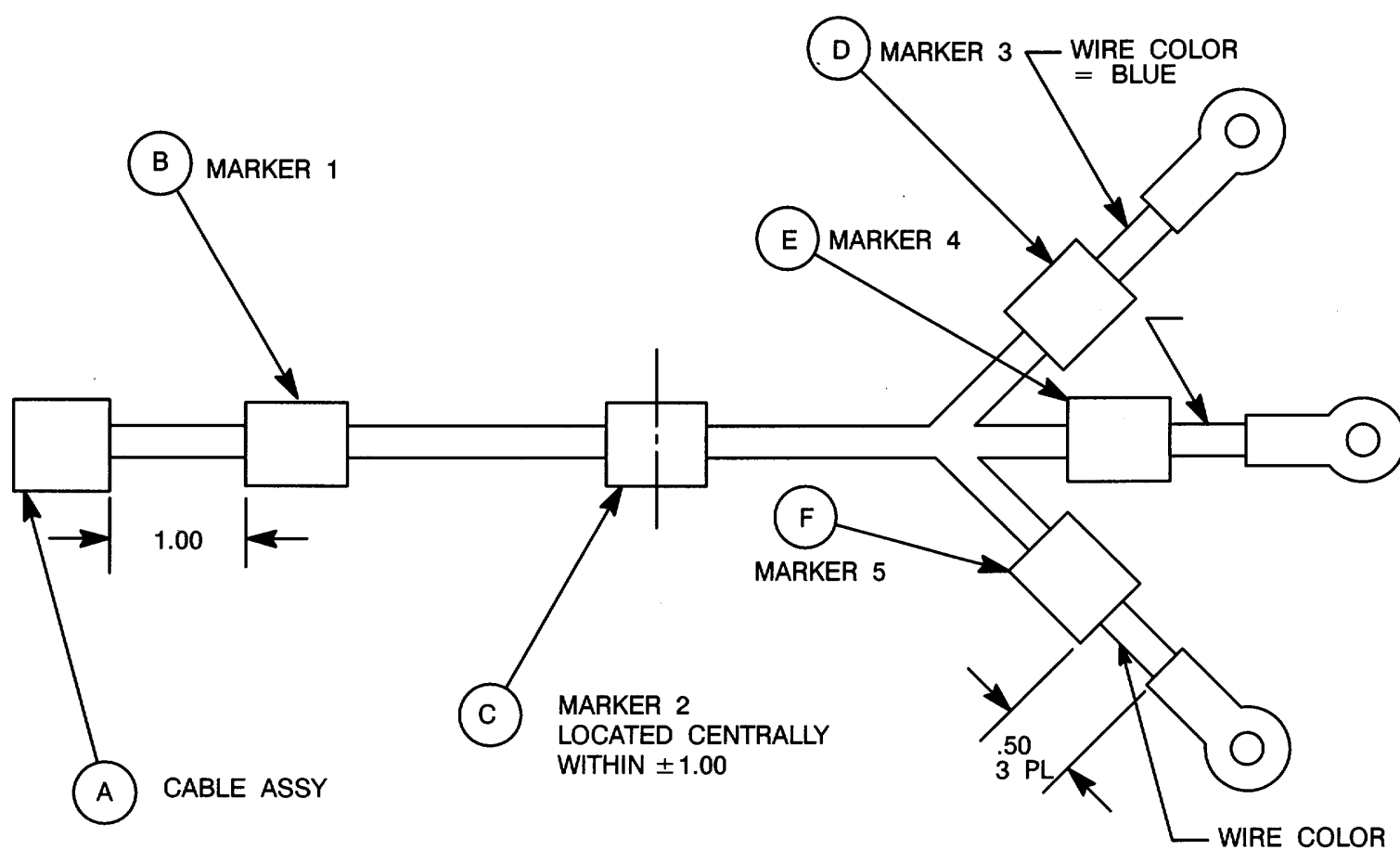

FIGURE 2

THIS DOCUMENT HAS BEEN PURCHASED BY THE GOVERNMENT AND MAY BE REPRODUCED AND USED IN CONNECTION WITH ANY GOVERNMENT PROCUREMENT OR MAINTENANCE OPERATION	SIZE	FSCM NO.	DRAWING NO.		
	A	80063	A3093476		
SCALE	NONE	LTR	E	SHEET	5

PARTS LIST					
QTY	ITEM	PART NO.	DESCRIPTION	SPEC/STD	FSCM NO.
22	1	A3092925-5	MARKER		80063
1	2	A3092669-7	CABLE ASSEMBLY, THIN WIRE TRIAX		80063
1	4	A3092719	CABLE ASSEMBLY, POWER FILTER		80063
1	5	A3093625	CABLE ASSEMBLY, FOER J3, JUMPER		80063

THIS DOCUMENT HAS BEEN PURCHASED BY THE GOVERNMENT AND MAY BE REPRODUCED AND USED IN CONNECTION WITH ANY GOVERNMENT PROCUREMENT OR MAINTENANCE OPERATION	SIZE	FSCM NO.	DRAWING NO.		
	A	80063	A3093476		
SCALE	NONE	LTR	E	SHEET	5

A3093476

CABLE SET, FIBER OPTIC ETHERNET REPEATER ASSEMBLY (Sheets 5 & 6 of 7)

DASH NO.	A CABLE ASSY	FIGURE NO.	B MARKER 1	C MARKER 2	D MARKER 3	E MARKER 4	F MARKER 5	NOTES
1								
2	FIND NO. 1, 2	1	P1 (A1A1A2J5)	W2 80063 A3093476-2	P2 (A1A1J3)			4
3 1, 4	FIND NO.	3	P1 (A1A1A1J4)	W3 80063 A3093476-3	A (FL1A)	GND (FL1GND)	C (FL1 C)	4
4 1, 5	FIND NO.	1		W4 80063 A3093476-4				4

0440N	THIS DOCUMENT HAS BEEN PURCHASED BY THE GOVERNMENT AND MAY BE REPRODUCED AND USED IN CONNECTION WITH ANY GOVERNMENT PROCUREMENT OR MAINTENANCE OPERATION	SIZE	FSCM NO.	DRAWING NO.	
		A	80063	A3093476	
		SCALE	NONE	LTR	E SHEET 7

A3093476

CABLE SET, FIBER OPTIC ETHERNET REPEATER ASSEMBLY (Sheet 7 of 7)

NOTE: DATA MARKED WITH AN ASTERISK IS PECULIAR TO A PRIOR MANUFACTURER.
IT DOES NOT TAKE PRECEDENCE OVER ANY OTHER DATA ON THIS DRAWING, AND
IS NOT CONTRACTUALLY BINDING ON EITHER THE CONTRACTOR OR THE GOVERNMENT.

THIS DOCUMENT HAS BEEN PURCHASED BY THE GOVERNMENT AND MAY BE REPRODUCED AND USED IN CONNECTION WITH ANY GOVERNMENT PROCUREMENT OR MAINTENANCE OPERATION.

REVISIONS					
EFF	LTR	NO.	DESCRIPTION	DATE	APPROVED
ALL	A		INC ECN 92954	88-05-27	LC CP JB
ALL	B		INC ECN 97107	88-08-27	DD CP JB
	C		INC ECN 108676, EFF: 89-06-06	89-07-13	AH PRA JB
	D		INC ECN 110932, EFF: 89-07-13	89-08-03	AH PRA JB
	E		INC ECN 137739	91-03-21	LC Z

REV																				
SHEET																				
REV STATUS OF SHEETS	REV SHEET	E	E	C	E	A	A													
		1	2	3	4	5	6													
1. PREPARED IN ACCORDANCE WITH DOD-STD-100. 2. UNLESS OTHERWISE SPECIFIED, DIMENSIONS ARE IN INCHES.		ELECTROSPACE SYSTEMS, INC. DAAB07-86-C-J008					U.S. ARMY COMMUNICATIONS - ELECTRONIC COMMAND FORT MONMOUTH, NEW JERSEY 07703													
		APVD	M. MARTIN	88-04-27	DRAWING TITLE															
		ENGR	C. PYBUS	88-07-27	WIRING HARNESS, ENVIRONMENTAL CONTROL UNIT (ECU) CONTROL															
		ENGR	W. SHIELDS	88-04-27																
		CHECK	L. FETZER	88-04-27																
		DRAWN	L. CHATELAIN	88-04-27																
		REV			SIZE	FSCM NO.	DRAWING NO.													
NOTE 1		APVD			A	80063	A3093528													
NEXT ASSY USED ON		DATE			SCALE		NONE	E		SHEET 1 OF 6										
APPLICATION																				

NOTES:

1. SEE TABLE 1 FOR NEXT ASSEMBLY INFORMATION.

TABLE 1

DASH NO.	NEXT ASSY	USED ON	QTY	DASH NO.	NEXT ASSY	USED ON	QTY
-1	A3092696	DLA3092692	1	-2	A3092696	DLA3092692	1
-1	A3093146	DLA3092801	1	-2	A3093146	DLA3092801	1
-1	A3093146	DLA3092651	1	-2	A3093146	DLA3092651	1
-1	A3093146	DLA3092951	1	-2	A3093146	DLA3092951	1

- PART NUMBER 13216E6177 CONNECTOR IS SUPPLIED WITH ECU, DRAWING A3093379.
- ALL SOLDERING PER MIL-STD-454, REQUIREMENT 5.
- WIRE LENGTH FOR A3093528-1 IS 48 INCHES AND THE WIRE LENGTH FOR A3093528-2 IS 84 INCHES WITH A TOLERANCE OF -0.00 + 2.00 INCHES.
- SLEEVE EXPOSED CONTACT WITH ITEM 2, AS REQUIRED.
- SLEEVE EXPOSED CONTACT WITH ITEM 3, AS REQUIRED.
- USE TABLE 2 FOR CABLE MARKER INFORMATION. INSTALL THE CABLE MARKER 3.00 + 1.00 FROM THE BACK OF THE CONNECTOR. MARK PER A3092959, DECAL FABRICATION.

TABLE 2

CABLE	MARKER	QTY	ITEM
A3093528-1	A3093528-1 FSCM 80063 M/W A14A1J1	1	1
A3093528-2	A3093528-2 FSCM 80063 M/W A14A2J1	1	1

8. THIS END LEFT UNTERMINATED.

THIS DOCUMENT HAS BEEN PURCHASED BY THE GOVERNMENT AND MAY BE REPRODUCED AND USED IN CONNECTION WITH ANY GOVERNMENT PROCUREMENT OR MAINTENANCE OPERATION	SIZE	FSCM NO.	DRAWING NO.	
	A	80063	A3093528	
SCALE		NONE	LTR	E SHEET
				2

A3093528

WIRING HARNESS, ENVIRONMENTAL CONTROL UNIT (ECU) CONTROL (Sheets 1 & 2 of 6)

PARTS LIST					
QTY	ITEM	PART NO.	DESCRIPTION	SPEC/STD	FSCM NO.
NOTE 4	E12-0	M16878/4BLE0	WIRE, AWG 12, BLACK	MIL-W-16878/4	81349
NOTE 4	E12-2	M16878/4BLE2	WIRE, AWG 12, RED	MIL-W-16878/4	81349
NOTE 4	E12-4	M16878/4BLE4	WIRE, AWG 12, YELLOW	MIL-W-16918/4	81349
NOTE 4	E12-5	M16878/4BLE5	WIRE, AWG 12, GREEN	MIL-W-16878/4	81349
NOTE 4	E12-6	M16878/4BLE6	WIRE, AWG 12, BLUE	MIL-W-16878/4	81349
NOTE 4	E12-9	M16878/4BLE9	WIRE, AWG 12, WHITE	MIL-W-16878/4	81349
NOTE 4	E16-3	M16878/4BJE3	WIRE, AWG 16, ORANGE	MIL-W-16878/4	81349
NOTE 4	E16-7	M16878/4BJE7	WIRE, AWG 16, VIOLET	MIL-W-16878/4	81349
NOTE 4	E16-8	M16878/4BJE8	WIRE, AWG 16, GRAY	MIL-W-16878/4	81349
NOTE 4	E16-90	M16878/4BJE90	WIRE, AWG 16, WHITE/BLACK	MIL-W-16878/4	81349
NOTE 4	E16-91	M16878/4BJE91	WIRE, AWG 16, WHITE/BROWN	MIL-W-16878/4	81349
NOTE 4	E16-92	M16878/4BJE92	WIRE, AWG 16, WHITE/RED	MIL-W-16878/4	81349
NOTE 4	E16-93	M16878/4BJE93	WIRE, AWG 16, WHITE/ORANGE	MIL-W-16878/4	81349
NOTE 4	E16-94	M16878/4BJE94	WIRE, AWG 16, WHITE/YELLOW	MIL-W-16878/4	81349
NOTE 4	E16-95	M16878/4BJE95	WIRE, AWG 16, WHITE/GREEN	MIL-W-16878/4	81349
NOTE 4	E16-96	M16878/4BJE96	WIRE, AWG 16, WHITE/BLUE	MIL-W-16878/4	81349

0530N-2	THIS DOCUMENT HAS BEEN PURCHASED BY THE GOVERNMENT AND MAY BE REPRODUCED AND USED IN CONNECTION WITH ANY GOVERNMENT PROCUREMENT OR MAINTENANCE OPERATION	SIZE A	FSCM NO. 80063	DRAWING NO. A3093528	
		SCALE NONE	LTR C	SHEET	3

PARTS LIST					
QTY	ITEM	PART NO.	DESCRIPTION	SPEC/STD	FSCM NO.
NOTE 4	E16-98	M16878/4BJE98	WIRE, AWG 16, WHITE/GRAY	MIL-W-16878/4	81349
NOTE 4	E20-901	M16878/4BGE901	WIRE, AWG 20, WHITE/BLACK/BROWN	MIL-W-16878/4	81349
NOTE 4	E20-905	M16878/4BGE905	WIRE, AWG 20, WHITE/BLACK/GREEN	MIL-W-16878/4	81349
NOTE 4	E20-906	M16878/4BGE906	WIRE, AWG 20, WHITE/BLACK/BLUE	MIL-W-16878/4	81349
NOTE 4	E20-907	M16878/4BGE907	WIRE, AWG 20, WHITE/BLACK/VIOLET	MIL-W-16878/4	81349
NOTE 4	E20-908	M16878/4BGE908	WIRE, AWG 20, WHITE/BLACK/GRAY	MIL-W-16878/4	81349
NOTE 4	E20-912	M16878/4BGE912	WIRE, AWG 20, WHITE/BROWN/RED	MIL-W-16878/4	81349
NOTE 4	E20-913	M16878/4BGE913	WIRE, AWG 20, WHITE/BROWN/ORANGE	MIL-W-16878/4	81349
NOTE 4	E20-914	M16878/4BGE914	WIRE, AWG 20, WHITE/BROWN/YELLON	MIL-W-16878/4	81349
1	1	A3092925-5	7 MARKER		80063
AR	2	M23053/5-103-9	SLEEVING, 3/32 INCH	MIL-I-23053/5	81349
AR	3	M23053/5-106-9	SLEEVING, 1/4 INCH	MIL-I-23053/5	81349
2	4	13216E6177	2 CONNECTOR, ECU		97403

THIS DOCUMENT HAS BEEN PURCHASED BY THE GOVERNMENT AND MAY BE REPRODUCED AND USED IN CONNECTION WITH ANY GOVERNMENT PROCUREMENT OR MAINTENANCE OPERATION	SIZE A	FSCM NO. 80063	DRAWING NO. A3093528	
	SCALE NONE	LTR E	SHEET	4

A3093528

WIRE NO. OR COLOR	FROM TERMINATION			TO TERMINATION			WIRE		FUNCTION	REMARKS
	REF DES	PIN	(I) ITEM (N) NOTE	REF DES	PIN	(I) ITEM (N) NOTE	ITEM	LENGTH		
91	P1	A1	14 N5			N8	E16-91	NOTE 4	ECU CTRL	WHT/BRN
92	P1	A2	14 N5			N8	E16-92	NOTE 4	ECU CTRL	WHT/RED
95	P1	A3	14 N5			N8	E16-95	NOTE 4	ECU CTRL	WHT/GRN
906	P1	A4	14 N5			N8	E20-906	NOTE 4	ECU CTRL	WHT/BLK/BLU
905	P1	A5	14 N5			N8	E20-905	NOTE 4	ECU CTRL	WHT/BLK/GRN
98	P1	A6	14 N5			N8	E16-98	NOTE 4	ECU CTRL	WHT/GRY
901	P1	A7	14 N5			N8	E20-901	NOTE 4	ECU CTRL	WHT/BLK/BRN
94	P1	A8	14 N5			N8	E16-94	NOTE 4	ECU CTRL	WHT/YEL
93	P1	A9	14 N5			N8	E16-93	NOTE 4	ECU CTRL	WHT/ORN
4	P1	A11	14 N6			N8	E12-4	NOTE 4	ECU CTRL	YEL
0	P1	A12	14 N6			N8	E12-0	NOTE 4	ECU CTRL	BLK
2	P1	A13	14 N6			N8	E12-2	NOTE 4	ECU CTRL	RED
6	P1	A14	14 N6			N8	E12-6	NOTE 4	ECU CTRL	BLU
5	P1	A15	14 N6			N8	E12-5	NOTE 4	ECU CTRL	GRN
9	P1	A16	14 N6			N8	E12-9	NOTE 4	ECU CTRL	WHT
8	P1	B2	14 N5			N8	E16-8	NOTE 4	ECU CTRL	GRY
908	P1	B3	14 N5			N8	E20-908	NOTE 4	ECU CTRL	WHT/BLK/GRY

0530N-2	THIS DOCUMENT HAS BEEN PURCHASED BY THE GOVERNMENT AND MAY BE REPRODUCED AND USED IN CONNECTION WITH ANY GOVERNMENT PROCUREMENT OR MAINTENANCE OPERATION	SIZE	FSCM NO.	DRAWING NO.			
		A	80063	A3093528			
		SCALE	NONE	LTR	A	SHEET	5

WIRE NO. OR COLOR	FROM TERMINATION			TO TERMINATION			WIRE		FUNCTION	REMARKS
	REF DES	PIN	(I) ITEM (N) NOTE	REF DES	PIN	(I) ITEM (N) NOTE	ITEM	LENGTH		
907	P1	B4	14 N5			N8	E20-907	NOTE 4	ECU CTRL	WHT/BLK/VIO
914	P1	B5	14 N5			N8	E20-914	NOTE 4	ECU CTRL	WHT/BRN/YEL
96	P1	B6	14 N5			N8	E16-96	NOTE 4	ECU CTRL	WHT/BLU
7	P1	B7	14 N5			N8	E16-7	NOTE 4	ECU CTRL	VIO
913	P1	B8	14 N5			N8	E20-913	NOTE 4	ECU CTRL	WHT/BRN/ORN
90	P1	B9	14 N5			N8	E16-90	NOTE 4	ECU CTRL	WHT/BLK
912	P1	B10	14 N5			N8	E20-912	NOTE 4	ECU CTRL	WHT/BRN/RED
3	P1	B11	14 N5			N8	E16-3	NOTE 4	ECU CTRL	ORN

THIS DOCUMENT HAS BEEN PURCHASED BY THE GOVERNMENT AND MAY BE REPRODUCED AND USED IN CONNECTION WITH ANY GOVERNMENT PROCUREMENT OR MAINTENANCE OPERATION	SIZE	FSCM NO.	DRAWING NO.				
	A	80063	A3093528				
		SCALE	NONE	LTR	A	SHEET	6

NOTES:

1. PREPARED IN ACCORDANCE WITH DOD-STD-100.
2. UNLESS OTHERWISE SPECIFIED, DIMENSIONS ARE IN INCHES.
3. UNLESS OTHERWISE SPECIFIED, TOLERANCES ARE: 2 PLACE DECIMALS +.02, 3 PLACE DECIMALS + .010, FRACTIONS + 1/32, ANGLES + 1 DEGREE, AND HOLE DIAMETERS + .005.
4. WORKMANSHIP SHALL BE IN ACCORDANCE WITH MIL-STD-454, REQUIREMENT 9.
5. DIMENSIONAL DATA IS BASED ON AMERICAN NATIONAL STANDARD ANSI Y14.5-1973.
6. MARK PER A3092959, DECAL FABRICATION.
7. PARTIAL REFERENCE DESIGNATIONS ARE SHOWN. FOR COMPLETE REFERENCE DESIGNATION, PREFIX WITH UNIT NUMBER AND SUBASSEMBLY DESIGNATION.
8. THIS NOTE INTENTIONALLY LEFT BLANK.
9. CONNECTOR J11 MOUNTS TO THE TRANSIT CASE.
10. INTERCONNECTION DIAGRAM IS DRAWING NO. A3092663.
11. COMPLETE PART NUMBER SHALL INCLUDE APPLICABLE DASH NUMBER.
12. CABLE MARKERS MAY BE APPLIED TO CABLES SUCH THAT MARKERS READ EITHER AWAY FROM CABLE END OR TOWARDS CABLE END.

D-1	THIS DOCUMENT HAS BEEN PURCHASED BY THE GOVERNMENT AND MAY BE REPRODUCED AND USED IN CONNECTION WITH ANY GOVERNMENT PROCUREMENT OR MAINTENANCE OPERATION	SIZE	FSCM NO.	DRAWING NO.		
		A	80063	A3093571		
		SCALE	NONE	LTR	E	SHEET 3

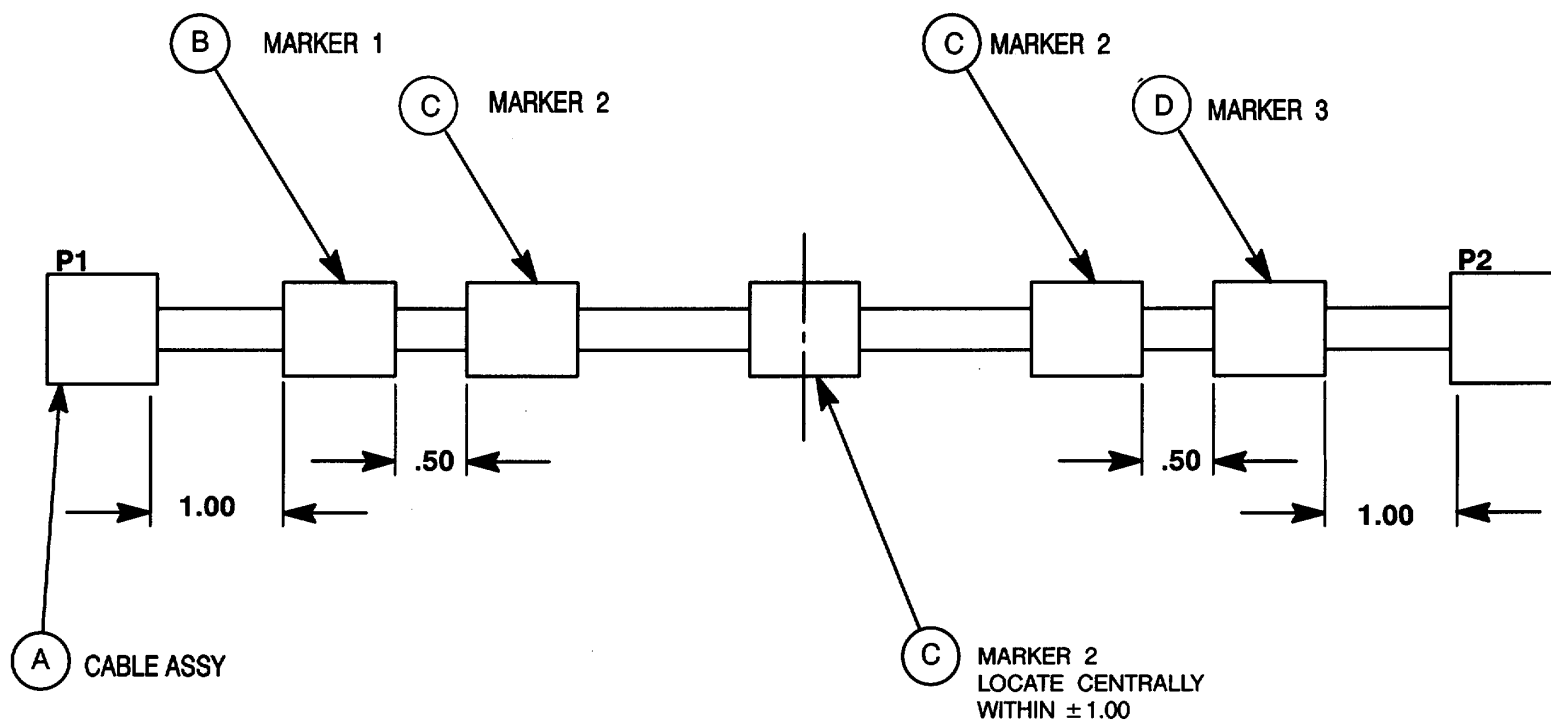

D-1	THIS DOCUMENT HAS BEEN PURCHASED BY THE GOVERNMENT AND MAY BE REPRODUCED AND USED IN CONNECTION WITH ANY GOVERNMENT PROCUREMENT OR MAINTENANCE OPERATION	SIZE	FSCM NO.	DRAWING NO.		
		A	80063	A3093571		
		SCALE	NONE	LTR	B	SHEET 1 OF 6

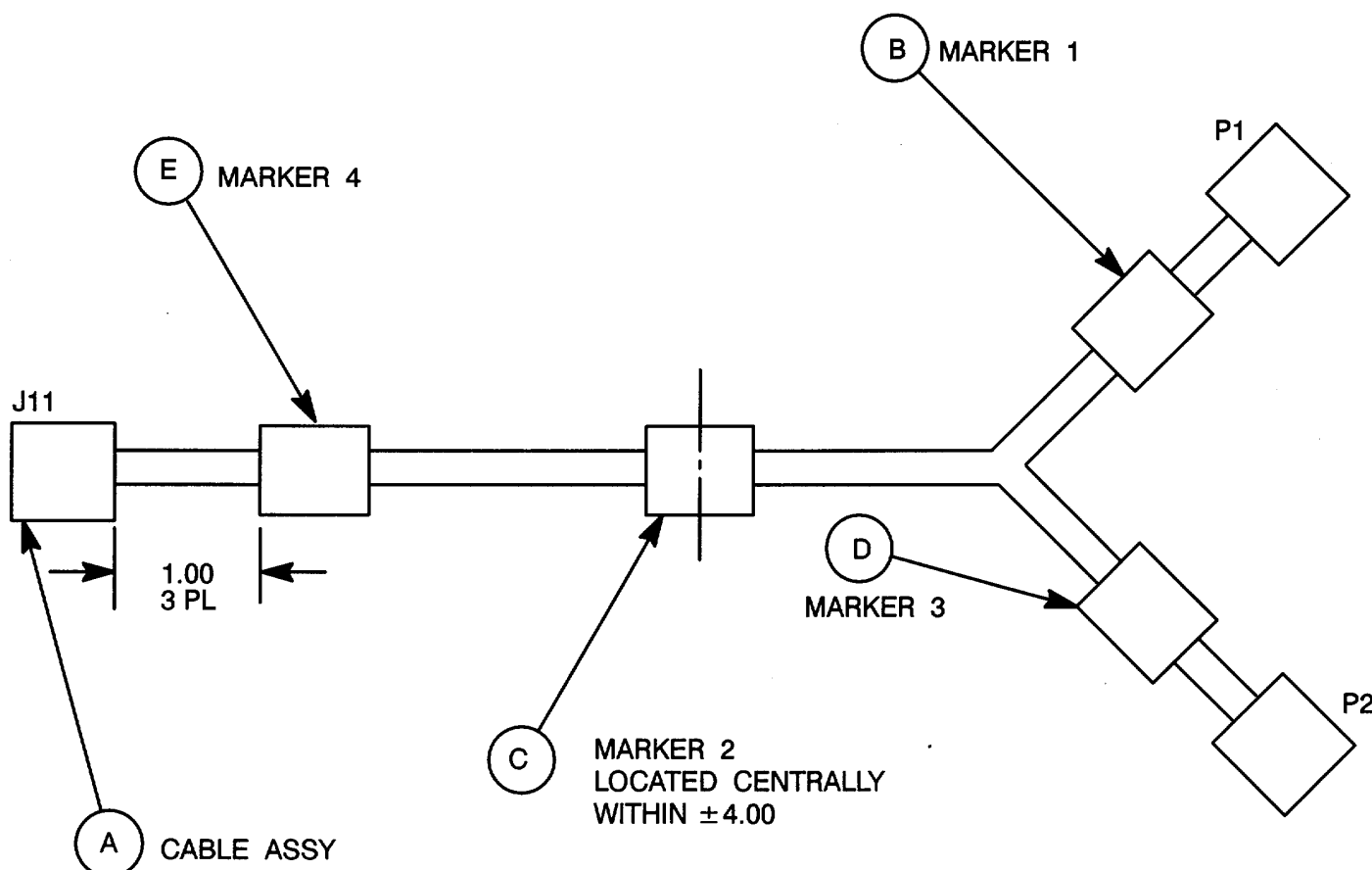

FIGURE 2

THIS DOCUMENT HAS BEEN PURCHASED BY THE GOVERNMENT AND MAY BE REPRODUCED AND USED IN CONNECTION WITH ANY GOVERNMENT PROCUREMENT OR MAINTENANCE OPERATION

SIZE
A

FSCM NO.
80063

DRAWING NO.
A3093571

SCALE

NONE

LTR

B

SHEET

5

PARTS LIST

QTY	FIND NO.	PART NO.	DESCRIPTION	FSCM NO.	NOTES
34	1	A3092925-5	MARKERS	80063	
5	2	A3092925-4	MARKERS	80063	
2	3	A3092669-5	CABLE ASSEMBLY, THIN WIRE TRIAX	80063	
1	4	A3093601-1	CABLE ASSEMBLY, FIBER OPTIC	80063	9
1	5	A3093597-6	CABLE ASSEMBLY, PRINTER	80063	
1	6	A3093644-2	CABLE ASSEMBLY, POWER, 120 VAC	80063	
2	7	A3093089	CABLE ASSEMBLY, POWER, WORKSTATION	80063	

THIS DOCUMENT HAS BEEN PURCHASED BY THE GOVERNMENT AND MAY BE REPRODUCED AND USED IN CONNECTION WITH ANY GOVERNMENT PROCUREMENT OR MAINTENANCE OPERATION

SIZE
A

FSCM NO.
80063

DRAWING NO.

A3093571

SCALE

NONE

LTR

E

SHEET

6

DASH NO.	A CABLE ASSY	FIGURE NO.	B MARKER 1	C MARKER 2	D MARKER 3	E MARKER 4	NOTES
1	FIND NO. 1, 4	2	P1 (A1A1J1)	W1 80063 A3093571-1	P2 (A1A1J2)	J11 (A1)	6, 9
2	FIND NO. 2, 5	1	P1 (A2J1)	W2 80063 A3093571-2	P2 (A3J2)		6
3	FIND NO. 1, 3	1	P1 (A3J5)	W3 80063 A3093571-3	P2 (A4J6)		6
4	FIND NO. 1, 3	1	P1 (A4J5)	W4 80063 A3093571-4	P2 (A1A1J5)		6
5	FIND NO. 1, 7	1	P1 120 VAC	W5 80063 A3093571-5	P2 A3J4		6
6							
7	FIND NO. 1, 7	1	P1 120 VAC	W7 80063 A3093571-7	P2 A4J4		6
8	FIND NO. 1, 6	1	P1 80063 120 VAC	W8 A3093571-8	P2 A1A1J3		6

D-1	THIS DOCUMENT HAS BEEN PURCHASED BY THE GOVERNMENT AND MAY BE REPRO- DUCED AND USED IN CONNECTION WITH ANY GOVERNMENT PROCUREMENT OR MAINTENANCE OPERATION	SIZE	FSCM NO.	DRAWING NO.	
		A	80063	A3093571	
		SCALE	NONE	LTR	E SHEET 7

CABLE SET, RTC (Sheet 7 of 7)

NOTE: DATA MARKED WITH AN ASTERISK (*) IS PECULIAR TO A PRIOR MANUFACTURER. IT DOES NOT TAKE PRECEDENCE OVER ANY OTHER DATA ON THIS DRAWING, AND IS NOT CONTRACTUALLY BINDING ON EITHER THE CONTRACTOR OR THE GOVERNMENT.

APPLICATION		REVISIONS					
NEXT ASSY	USED ON	EFF	LTR	NO.	DESCRIPTION	DATE	APVD
SEE PAGE 2		ALL	A		INC ECN 85817	88-03-16	RRCP
		ALL	B		INC ECN 88995	88-03-16	RRCP
		ALL	C		INC ECN 91683 & 91687		KA
		ALL	D		INC ECN 93387	88-06-29	TD
1. PREPARED IN ACCORDANCE WITH DOD-STD-100. 2. UNLESS OTHERWISE SPECIFIED, DIMENSIONS ARE IN INCHES.		ALL	E		INC ECN 102117	88-12-22	DN CP
		ALL	F		INC ECN 100337, ADDITION OF TEXT TO DOCUMENT CHANGED THE SHEET COUNT FROM 36 TO 38	88-02-16	VE PRA
		ALL	G		INC ECN 100339		
			H		INC ECN 97241, EFF: 3/20/89	89-04-13	VE TB
			J		INC ECN 97246, EFF: 3/20/89		
			K		INC ECN 131846	90-08-29	VE
			L		INC ECN 131946		
			M		INC ECN 137764	91-01-02	VE BM
		N		REPLACES REV M WITH CHANGES PER ECN 147266	92-10-06	MD CP	

SPECIFICATION CONTROL DRAWING

THIS DOCUMENT HAS BEEN PURCHASED BY THE GOVERNMENT AND MAY BE REPRODUCED AND USED IN CONNECTION WITH ANY GOVERNMENT PROCUREMENT OR MAINTENANCE OPERATION.	REV SHEET																	
	REV SHEET	N	N	N	N	N	N	N	N	N	N	N	N	N	N	N	N	N
	REV SHEET	29	30	31	32	33	34	35	36	37	38	39						
	REV SHEET	N	N	N	N	N	N	N	N	N	N	N	N	N	N	N	N	N
	REV SHEET	13	14	15	16	17	18	19	20	21	22	23	24	25	26	27	28	
	REV STATUS OF SHEETS	REV SHEET	N	N	N	N	N	N	N	N	N	N	N	N	N	N	N	N

ELECTROSPACE SYSTEMS, INC. DAAB07-86-C-J008		U.S. ARMY COMMUNICATIONS - ELECTRONICS COMMAND FORT MONMOUTH, NEW JERSEY 07703						
APVD	D. MORUE	87-8-5	DRAWING TITLE					
ENGR	D. PLEMONS	DP	POWER SOURCE, UNINTERRUPTIBLE, AC TO DC TO AC, 3 PHASE (5 KVA OUTPUT)					
ENGR	C. PYBUS	CP						
CHECK	C. REID	BM						
DRAWN	E. RICE	ER						
EV	P. PAO (LC-ED-MX)	3/16/93	SIZE	FSCM NO.	DRAWING NO.			
APVD	KS	LC-ED-MX	A	80063	A3093580			
DATE	3-16-93		SCALE	NONE	N	SHEET 1 OF 39		

WHEN REFERRING TO THIS DRAWING STATE DRAWING NO., APPLICABLE ISSUE LETTER IF ANY, AND DATE

APPLICATION

DASH NO.	NEXT ASSY	USED ON	QTY REQUIRED
-1	A3092651	DLA3092651	1
-1	A3092692	DLA3092692	1
-1	A3092801	DLA3092801	1
-1	A3092951	DLA3092951	1
-2	A3092651	DLA3092651	1
-2	A3092692	DLA3092692	1
-2	A3092801	DLA3092801	1
-2	A3092951	DLA3092951	1
-3	A3092651	DLA3092651	3
-3	A3092692	DLA3092692	3
-3	A3092801	DLA3092801	3
-3	A3092951	DLA3092951	3
-4	A3092651	DLA3092651	3
-4	A3092692	DLA3092692	3
-4	A3092801	DLA3092801	3
-4	A3092951	DLA3092951	3
-5	A3093419	DLA3093151	1
-6	A3093419	DLA3093151	2
-7	A3093419	DLA3093151	1
-8	A3093419	DLA3093151	2
-9	A3093419	DLA3093151	1
-10	A3093419	DLA3093151	1
-11	A3093419	DLA3093151	1
-12	A3093419	DLA3093151	1
-13	A3093419	DLA3093151	2
-14	A3093419	DLA3093151	2
-15	A3093419	DLA3093151	1
-16	A3092651	DLA3092651	3
-16	A3092692	DLA3092692	3
-16	A3092801	DLA3092801	3
-16	A3092951	DLA3092951	3

THIS DOCUMENT HAS BEEN PURCHASED BY THE GOVERNMENT AND MAY BE REPRODUCED AND USED IN CONNECTION WITH ANY GOVERNMENT PROCUREMENT OR MAINTENANCE OPERATION.	SIZE	FSCM NO.	DRAWING NO.	
	A	80063	A3093580	
	SCALE	NONE	N	SHEET 2

NOTES:

1. Prepared in accordance with DOD-STD-100.
2. Unless otherwise specified, dimensions are in inches.
3. Unless otherwise specified, tolerance
 - 2 place decimals ±.02
 - 3 place decimals ±.010
 - Angles ± 1°
 - Decimal hole diameters ± .005.
4. Dimensional data is based on American National Standard ANSI Y14.5-1973.
5. For provisioned spares for this item, see drawing number A3152573.

1. SCOPE

1.1 General. This specification establishes the requirements for manufacture and acceptance of and Uninterruptable Power Source (UPS) that shall provide uninterrupted AC power within the Tactical Command Control and Communications Central Processor, AN/TYQ-30, and the Tactical Command, Control and Communications Nodal Processor, AN/TYQ-31.

2. APPLICABLE DOCUMENTS

2.1 General. The following documents, of the issue in effect, (or the exact issue listed, if listed) form a part of this specification to the extent specified herein.

SPECIFICATIONS

MILITARY

MIL-B-5087B Bonding, Electrical, and Lightning Protection, for Aerospace Systems

MIL-I-45208A Inspection System Requirements

STANDARDS

MILITARY

MIL-STD45662 Calibration Systems Requirements

MIL-STD-461B Electromagnetic Emission and Susceptibility Requirements for the Control of Electromagnetic Interference
1 APR 1980

MIL-STD-781C Reliability Tests, Exponential Distribution

MIL-STD-810D Environmental Test Methods

MIL-STD-1399 Interface Standard for Shipboard Systems

HANDBOOKS

MILITARY

MIL-HDBK-217E Reliability Prediction of Electronic Equipment

2.2 Other Publications.

EIA-RS-310-77 Racks, Panels and Associated Equipment

U.S. ARMY COMMUNICATIONS ELECTRONICS COMMAND

A30993345 Label, Plastic-Interior

THIS DOCUMENT HAS BEEN PURCHASED BY THE GOVERNMENT AND MAY BE REPRODUCED AND USED IN CONNECTION WITH ANY GOVERNMENT PROCUREMENT OR MAINTENANCE OPERATION. S-1	SIZE	FSCM NO.	DRAWING NO. A3093580	
	A	80063	SHEET	3
	SCALE	NONE	N	SHEET 3

THIS DOCUMENT HAS BEEN PURCHASED BY THE GOVERNMENT AND MAY BE REPRODUCED AND USED IN CONNECTION WITH ANY GOVERNMENT PROCUREMENT OR MAINTENANCE OPERATION. S-1	SIZE	FSCM NO.	DRAWING NO. A3093580	
	A	80063	SHEET	4
	SCALE	NONE	N	SHEET 4

3. REQUIREMENTS

3.1 General. The individual item requirements shall be as specified herein.

3.2 Mechanical details of units or parts. The physical design, dimensions, and tolerances shall be as specified in figures specified by Table I.

3.2.1 Design and construction. The uninterruptible power source, UPS, including batteries, shall be rack mountable (19 inches wide) per EIA-RS-310-77. It shall consist of the panel/chassis assemblies and cable assemblies as shown in Table I.

3.2.1.1 Panel/chassis assembly heights. The panel/chassis assembly heights shall be as shown in Table I.

3.2.1.2 Panel/chassis assembly depth. The overall chassis depth shall not exceed 22.0 inches excluding connectors, switches, shock plates, and front panels.

3.2.1.3 Panel/chassis assembly arrangement. The UPS shall be designed around the panel arrangement as shown in Figure 1.

3.2.1.4 Chassis covers. All panel/chassis shall be provided with bottom and top covers that will match with the chassis.

3.2.2 Controls, indicators and alarms. All operational controls and indicators shall be located and clearly marked on the front panel. Alarm contacts shall be located and clearly marked on the rear of the chassis.

3.2.2.1 Operational controls. Panel controls shall include the following:

- (a) Line input circuit breaker.
- (b) Battery circuit breaker.
- (c) Manual "UPS-LINE" breaker.
- (d) 50/60 Hz frequency select switch.
- (e) Meter select switch

3.2.2.2 Indicators. Panel indicators shall include the following:

- (a) Line Failure (Red).
- (b) Low Battery (Red).
- (c) Bypass (Red).
- (d) System On. (Green).
- (e) System Output Voltmeter.
- (f) Inverter Bypass Indicator (Red).

THIS DOCUMENT HAS BEEN PURCHASED BY THE GOVERNMENT AND MAY BE REPRODUCED AND USED IN CONNECTION WITH ANY GOVERNMENT PROCUREMENT OR MAINTENANCE OPERATION. S-1	SIZE	FSCM NO.	DRAWING NO.
	A	80063	A3093580
SCALE	NONE	N	SHEET 5

3.2.2.3 Alarm contacts. External alarm indications shall be provided as single pole, normally open relay contacts for the

- (a) AC Input Line Failure.
- (b) UPS Bypass.
- (c) Low Battery Conditions.

3.2.2.4 Non-operational controls.

- (a) Battery On/Off Switch, located on the rear of the battery assembly.

3.2.3 Battery requirements. In the event that AC line power fails, the UPS shall provide a 5 kVA of battery supplied output for ten (10) minutes.

3.2.3.1 Battery maintenance. Batteries shall be leak proof and maintenance free.

3.2.3.2 Corrosive gas. Batteries shall not generate corrosive gas.

3.2.3.3 Battery orientation. Batteries shall charge, discharge and store in any position defined as horizontal up to but not exceeding a 90 degree angle from the battery's normal horizontal-position.

3.2.4 EMI/EMC requirements. Construction shall be accomplished in a manner to minimize electromagnetic interference (EMI). Interference control measures such as filtering, wire routing, component location and shielding shall be used to meet the requirements of MIL-STD-461B for class C2 equipment.

3.2.5 Bonding. Equipment shall comply with bonding requirements of MIL-B-5087B, paragraph 3.3.3.

3.2.6 Weight. The weights of the assemblies shown in Table I shall not exceed those specified.

3.2.7 Connectors. All connection to UPS chassis shall be via connectors. Terminal boards or other open air connections shall be prohibited. The one exception shall be chassis ground lugs.

3.3 Electrical operation. The UPS shall accept AC power and provide an uninterruptible AC output. The AC line input shall be either 50 or 60 Hz nominal. A manual front panel switch shall be provided to choose the correct input frequency. In the case of a line failure, the battery supplied AC output shall correspond to the switch setting.

3.3.1 Input requirements.

3.3.1.1 Input voltage. 120/208 VAC, ± 10%, 3 phase, Wye.

3.3.1.2 Input frequency. 48 ~ 52Hz or 58 ~ 62Hz.

3.3.1.3 Power factor. ± 0.5 (worst case)

THIS DOCUMENT HAS BEEN PURCHASED BY THE GOVERNMENT AND MAY BE REPRODUCED AND USED IN CONNECTION WITH ANY GOVERNMENT PROCUREMENT OR MAINTENANCE OPERATION. S-1	SIZE	FSCM NO.	DRAWING NO.
	A	80063	A3093580
SCALE	NONE	N	SHEET 6

3.3.2 Output requirements.

3.3.2.1 Output voltage. 118/204 ±3% VAC, 3 phase, when applied over the conditions specified in 3.3.2.3 thru 3.3.2.9.

3.3.2.1.1 Output voltage adjustment. ±10%.

3.3.2.2 Output frequency. 50 or 60 Hz.

3.3.2.2.1 Output frequency accuracy. + 0.1% of input frequency, or the selected frequency during free running conditions.

3.3.2.2.2 Output frequency stability (free-running). ±0.01% over a 2 minute period, ±0.1% over a 10 minute period.

3.3.2.2.3 Line synchronization. Capture range ± 2.0 Hz from selected nominal setting at a 1 Hz per second slew rate.

3.3.2.3 Waveform. Sinewave.

3.3.2.3.1 Distortion. Equipment shall meet a total of not more than 3% total harmonic distortion.

3.3.2.4 Total power output. 5 kVA, 3 phase.

3.3.2.4.1 Transient response time. 500 microsecond maximum for a 0-100% load change.

3.3.2.5 Current output per phase. 15 A.

3.3.2.6 Load power factor range. There shall be no degradation in performance due to power factors of 0.5 leading or lagging of the system load.

3.3.2.7 Overload rating. 125% for 10 minutes, 150% for 30 seconds, 200% for 1 second.

3.3.2.8 Automatic transfer. Upon inverter failure or overload, there shall be a transfer time of not more than 12 ms to the bypass line. After removal of overload, retransfer back to the inverter shall be accomplished by activation of the BYPASS RESET controls.

3.3.2.9 Phase imbalance operation. There shall be no degradation in performance while all phase loads are balanced within 20%.

3.3.2.10 Conversion efficiency. AC-to-DC-to-AC conversion shall be 71-5% minimum at a 5 kVA unity power factor load

3.3.2.11 Input/output isolation. Power input and output shall maintain a neutral common from the UPS input to the UPS output.

3.3.2.12 UPS block diagram. See Figure 11.

3.4 Marking.

3.4.1. Panel/chassis. Each panel/chassis shall be marked permanently and legibly with the appropriate military part number (from Table I), serial number, input voltage, frequency and current (or power on either the front panel or rear of chassis).

3.4.2 Front panel. Front panels shall be painted light cardinal gray series 1103 per FED-STD-59526595 and shall be marked per the painting and marking figures of this specification.

3.4.3 Connector identification. Each connector on each UPS chassis shall be clearly identified by a permanent mark on the chassis, (see marking figure for each panel/chassis).

3.4.4 Cable assembly markings. Each cable assembly shall have an identification tag on both ends with legible and permanent markings of the manufacturer's part number.

3.5 Environmental. The UPS shall withstand the following environmental conditions.

3.5.1 Temperature range.

Operating: 0° to +50°C

Storage: -40°C to +70°C

3.5.2 Vibration. The UPS shall be designed to meet the vibration requirements of MIL-STD-810D. method 513.3, procedure III, category 3. The levels and duration shall be as specified in Figure 12.

3.5.3 Shock. The UPS shall be designed to withstand 40 g's of side-to-side shock, shock, half sinewave for 40 msec after being rack mounted.

3.5.4 Humidity. UPS shall be designed to operate without degradation in performance and shall sustain no physical damage during and after 15 cycles of temperatures and relative humidities given in MIL-STD-810D, Table 507.1-I, Cycle 4. Humidity tests are with equipment non-operating except at the operational check points-as specified by MIL-STD-810D.

3.5.5 Altitude. The UPS shall be designed to operate between sea level and 10,000 feet above sea level. It shall be designed to be stowed at sea level to 40,000 feet. Tests shall be conducted at 25 ± 5 degrees C.

3.6 Maintainability.

3.6.1 Organizational level. UPS is not subject to maintenance at the organizational level.

3.6.2 Intermediate level. The Mean Time to Repair (MTTR) shall be no greater than 60 minutes.

3.7 Reliability. Equipment shall have a Mean Time Between Failure (MTBF) of 5,000 hours minimum for a Ground Mobile (GM) environment IAW MIL-.HDBK-217E..

THIS DOCUMENT HAS BEEN PURCHASED BY THE GOVERNMENT AND MAY BE REPRODUCED AND USED IN CONNECTION WITH ANY GOVERNMENT PROCUREMENT OR MAINTENANCE OPERATION. S-1	SIZE	FSCM NO.	DRAWING NO. A3093580	
	A	80063	SHEET	3
	SCALE	NONE	N	SHEET 3

THIS DOCUMENT HAS BEEN PURCHASED BY THE GOVERNMENT AND MAY BE REPRODUCED AND USED IN CONNECTION WITH ANY GOVERNMENT PROCUREMENT OR MAINTENANCE OPERATION. S-1	SIZE	FSCM NO.	DRAWING NO. (A3093580)	
	A	80063	SHEET	6
	SCALE	NONE	N	SHEET 4

3.8 Equipment manual. A user's manual shall be furnished by the manufacturer that details unpackaging, installation, operation and major equipment components.

3.9 Workmanship. Parts shall be free from surface and finish flaws that affect life or serviceability. Parts shall be finished smooth and shall have rounded edges with no evidence of chipping, cracking, deterioration, disintegration, or burrs.

3.10 Decal. When part number A3093580-3 is a spares procurement then procure and adhere A3093345-233 to the -3 chassis. When A3093580-4 is a spares procurement then procure and adhere A3093345-220 to the -4 chassis. For either chassis the decal shall be placed on the top surface located on the center line ± 1.00 and 2.00 ± 1.00 from the back surface of the front panel.

4. QUALITY ASSURANCE PROVISIONS

4.1 Responsibility for inspection. Unless otherwise specified, the manufacturer is responsible for all inspection requirements as specified herein. Except as otherwise specified, the manufacturer may use his own or other facilities suitable for the performance of the inspection requirements specified herein. The purchaser reserves the right to perform any of the inspections set forth in the specification where such inspections are deemed necessary to assure equipment conforms to stated requirements. All test equipment shall be calibrated IAW MIL-STD-45662.

4.2 Quality conformance inspections. Quality conformance inspections shall be as specified in Table III. Quality assurance shall keep records for a minimum of three (3) years. A certificate of compliance with the inspections specified herein shall be submitted by the manufacturer for all equipment purchased.

4.3 Quality conformance testing. Quality conformance testing shall be as specified in Table III. Quality assurance shall keep records for a minimum of three (3) years. The purchaser reserves the right to witness any of the test set forth in this specification where sub tests are deemed necessary to assure the equipment conforms to the stated requirements.

4.3.1 Burn-in test. The manufacturer shall assure that each piece of equipment is subjected to a minimum 48 hours on-time burn-in period. During the last 24 hours of burn-in, equipment must operate failure free. Each equipment which fails during the final 24-hour period shall be repaired and returned to test until it successfully survives a 24-hour period without failures. Failures which occur during burn-in shall be documented in a Failure Analysis Report which shall include the cause(s) and corrective action along with the effectivity of any design change. The FARs will be sent with each unit.

4.3.1.1 Burn-in conditions.

(a) Thermal stresses shall be applied at a minimum temperature of 80 degrees F not to exceed the operating temperature of the unit of 122 deg. FE

(b) The equipment shall be operated throughout the thermal stress period with repetitive load cycled for 3 hours at 5 kVA unity power factor and 3 hours at no load.

4.3.1.1 Burn-in conditions. (Continued)

(c) Prior to application of thermal stresses, each piece of equipment shall be subjected to random vibrations. Vibration levels shall be in accordance with paragraph 4.4.1 of MIL-STD-781C except that the maximum level shall be .01 g²/Hz for a total Grms level of 3.2. (See Figure 13). The Vibration levels shall be applied to each of the three (3) planes. The number of applied planes may be reduced, subject to purchaser approval, if it is determined that 1 or 2 planes predominate in screening out defects. Power is not required to be applied to the system during the actual vibration of the equipment.

4.3.1.2 Operating modes. During equipment burn-in operational tests, the equipment shall operate in the following modes:

- (a) Load UPS powered.
- (b) Load line powered.
- (c) Load battery powered (for required 10 minutes) performed at the 24 hour point of the burn-in test.

4.3.1.3 Operational test load. All tests shall be performed with a 5 kVA load. The power factor of the load shall be variable from .5 leading to .5 lagging.

4.3.1.4 Burn-in operational tests. A test shall be performed on the equipment prior to burn-in, prior to and after the last 24 hour failure-free period, and on a daily basis, during burn-in. The operational test should check those parameters necessary to assure correct equipment operation.

4.3.1.5 Burn-in data. Burn-in data shall be submitted as required to the contract or purchase order.

4.4 Quality program requirements. The existing quality system shall be tailored to meet the intent of MIL-T-45208A for this procurement.

4.5 Decal. When either A3093580-3 or A3093580-4 is a spares procurement, then inspect either the -3 or -4 chassis for compliance with the requirement of paragraph 3.10.

5. PACKAGING

5.1 Packaging requirements. All units shall be adequately protected by proper packaging according to normal practices in order to prevent contamination, loss or damage in transit. Shipping containers shall be marked with manufacturer's name or trademark and part number.

THIS DOCUMENT HAS BEEN PURCHASED BY THE GOVERNMENT AND MAY BE REPRODUCED AND USED IN CONNECTION WITH ANY GOVERNMENT PROCUREMENT OR MAINTENANCE OPERATION. S-1	SIZE	FSCM NO.	DRAWING NC
	A	80063	A3093580
	SCALE	NONE	N
			SHEET 9
			SHEET 9

THIS DOCUMENT HAS BEEN PURCHASED BY THE GOVERNMENT AND MAY BE REPRODUCED AND USED IN CONNECTION WITH ANY GOVERNMENT PROCUREMENT OR MAINTENANCE OPERATION. S-1	SIZE	FSCM NO.	DRAWING NO.
	A	80063	
	SCALE	NONE	N
			SHEET 10
			SHEET 4

6. NOTES

6.1 Suggested source(s) of supply. Identification of the suggested source(s) of supply herein is not to be construed as a guarantee of present or continued availability as a source of supply for the item(s).

MILITARY IDENTIFICATION NUMBER	VENDOR	
	CAGE CODE	PART NUMBER
A3093580	53636	104-472-000
A3093580-1	53636	104-351-000
A3093580-2	53636	104-354-000
A3093580-3 1/	53636	104-348-000
A3093580-4 2/	53636	104-357-000
A3093580-5	53636	104-897-001
A3093580-6	53636	104-897-002
A3093580-7	53636	104-898-001
A3093580-8	53636	104-898-002
A3093580-9	53636	104-899-001
A3093580-10	53636	104-899-002
A3093580-11	53636	104-899-003
A3093580-12	53636	104-900-001
A3093580-13	53636	104-900-002
A3093580-14	53636	104-901-001
A3093580-15	53636	104-901-002
A3093580-16 2/	53636	3018

1/ If part number is a spares procurement see paragraph 3.10.

2/ If part number is a spares procurement see paragraph .3.10.

Vendor CAGE Code

53636

Vendor Name and Address

Behlman, An Astrosystems Company
6 Nevada Dr.
Lake Success, NY 11042

THIS DOCUMENT HAS BEEN PURCHASED BY THE GOVERNMENT AND MAY BE REPRODUCED AND USED IN CONNECTION WITH ANY GOVERNMENT PROCUREMENT OR MAINTENANCE OPERATION. S-1	SIZE	FSCM NO.	DRAWING NO.	
	A	80063	A3093580	
	SCALE	NONE	N	SHEET 11

6.2 Intended use. The UPS system shall accept AC line power and provide conditioned, uninterrupted AC power to electronic devices in a shelter environment. It is intended that the UPS shall be maintained by military personnel.

6.3 Ordering data. Procurement documents should specify the title, number and date of this specification.

6.4 Data requirements. A data package shall accompany each item and shall include the following:

- (a) User's manual, when specified by purchase order.
- (b) Certificate(s) of compliance verifying inspections and tests.
- (c) Test data.

THIS DOCUMENT HAS BEEN PURCHASED BY THE GOVERNMENT AND MAY BE REPRODUCED AND USED IN CONNECTION WITH ANY GOVERNMENT PROCUREMENT OR MAINTENANCE OPERATION. S-1	SIZE	FSCM NO.	DRAWING NO.	
	A	80063	A3093580	
	SCALE	NONE	N	SHEET 12

TABLE 1. Dash number description and physical requirements

THIS DOCUMENT HAS BEEN PURCHASED BY THE GOVERNMENT AND MAY BE REPRODUCED AND USED IN CONNECTION WITH ANY GOVERNMENT PROCUREMENT OR MAINTENANCE OPERATION. S-1	1/ A3093580 PART NO	NAME ASSEMBLY	PANEL HEIGHT INCHES	DIMENSIONS FIGURE	CHASSIS RECPTS. & CABLE PLUGS	MAX WEIGHT/ (LB)	QTY PER SYST.
	1	CONTROL ASSEMBLY	7.0	2A-C	TABLE II, FIG. 2C	33	1
	2	INPUT ASSEMBLY	7.0	3A-C	TABLE II, FIG. 3C	176	1
	3	INVERTER ASSEMBLY	5.25	4A-C	TABLE II, FIG. 4C	97	3
	4	BATTERY ASSEMBLY	9.0	5A-C	TABLE II, FIG. 5C	158	3
	5,6	CABLE ASSEMBLY, CONTROL/INVERTER	NA	6	FIG. 6		1,2
	7,8	CABLE ASSEMBLY, CONTROL/INVERTER D.C.	NA	7	FIG. 7		1,2
	9,10,11	CABLE ASSEMBLY, BATTERY/CONTROL	NA	8	FIG. 8		1,1,1
	12,13	CABLE ASSEMBLY, INVERTER/CONTROL	NA	9	FIG. 9		1,2
	14,15	CABLE ASSEMBLY, INVERTER/INPUT	NA	10	FIG. 10		2,1
	16	BATTERY ASSEMBLY	9.0	5A-C	TABLE II, FIG. 5C	42	3

1/ Uninterruptible power source consists of dash numbers 1 through 15 quantities of each assembly as listed.

	SHEET 13
--	-----------------

SIZE **A**
 FSCM NO. **80063**
 DRAWING NO. **A3093580**

SCALE NONE
 N

13

TABLE II. Panel/chassis receptacles

DASH NO	NAME OF ASSEMBLY	CHASSIS "J" NO	RECEPTACLE PART NO	CONTACT PART NO	CONTACT TYPE	RECEPTACLE DESCRIPTION
1	CONTROL	J1, J3, J5, J9	206036-1	201578-1	MALE	16 pin, male, circular, with square mounting flange
		J2, J4, J6, J10	206425-1	66258-3	FEMALE	3 pin, female, high current with square mounting flange
		J7, J8, J14	206036-2	66261-3	MALE	3 pin, male, high current with square mounting flange
		J11, J12, J13	206137-1	66261-3	MALE	7 pin, male, high current with square mounting flange
		J15	206227-1	662258-3	FEMALE	7 pin, female, high current with square mounting flange
2	INPUT	J1, J2, J3	206227-1	662258-3	FEMALE	7 pin, female high current with square mounting flange
		J4	206137-1	66261-3	MALE	7 pin, male, high current with square mounting flange
3	INVERTER	J1	206036-1	201578-3	MALE	16 pin, male, circular, with square mounting flange
		J2	206036-2	66261-3	MALE	3 pin, male, high current with square mounting flange
		J3	206137-1	66261-3	MALE	7 pin, male, high current with square mounting flange
		J4	206227-1	66258-1	FEMALE	7 pin, female, high current with square mounting flange
4	BATTERY	J1	206425-1	66258-3	FEMALE	3 pin, female, high current with square mounting flange
16	BATTERY	J1	206425-1	66258-3	FEMALE	3 pin, female, high current with square mounting flange

1/ Uninterruptible power source consists of dash numbers 1 through 9 and quantities of each assembly as listed

THIS DOCUMENT HAS BEEN PURCHASED BY THE GOVERNMENT AND MAY BE REPRODUCED AND USED IN CONNECTION WITH ANY GOVERNMENT PROCUREMENT OR MAINTENANCE OPERATION	SIZE	FSCM NO.	DRAWING NO.	
	A	80063	A3093580	SHEET 14
	SCALE NONE	LTR	SHEET	14

POWER SOURCE UNINTERRUPTIBLE
 AC TO DC TO AC, 3 PHASE, 5kVA out
 (UPS)
 Sheets 13 & 14 of 39)

TABLE III. Inspection/test matrix

PARAGRAPH	REQUIREMENT	*I	I	A
3.2.1.1	Width	X		
3.2.1.2	Height	X		
3.2.1.3	Depth	X		
3.2.2	Controls, Indicators and Alarms	X		
3.2.2.1	Controls	X	X	
3.2.2.2	Indicators	X	X	
3.2.2.3	Alarm Contacts	X	X	
3.2.3.1	Battery Maintenance	X		
3.2.3.2	Corrosive Gas	X		
3.2.3.3	Battery Orientation		F	
3.2.4	EMI/EMC		F	
3.2.5	Bonding	X	F	
3.2.6	Weight		F	
3.2.7	Connectors	X		
3.3.1.1	Input Voltage		X	
3.3.1.2	Input Frequency		X	
3.3.1.3	Power Factor		F	
3.3.2.1	Output Voltage		X	
3.3.2.1.1	Output Voltage Adjustment		F	
3.3.2.2	Output Frequency		X	
3.3.2.2.1	Output Frequency Accuracy		F	
3.3.2.2.2	Output Frequency Stability (free-running)		F	
3.3.2.2.3	Line Synchronization		X	

X = Both, First Article and Operational Burn-in test
 F = First Article only

THIS DOCUMENT HAS BEEN PURCHASED BY THE GOVERNMENT AND MAY BE REPRODUCED AND USED IN CONNECTION WITH ANY GOVERNMENT PROCUREMENT OR MAINTENANCE OPERATION. S-1	SIZE	FSCM NO.	DRAWING NO.	
	A	80063	A3093580	
	SCALE	NONE	N	SHEET 15

TABLE III. Inspection/test matrix (Continued)

PARAGRAPH	REQUIREMENT	*I	I	A
3.3.2.3	Waveform		X	
3.3.2.3.1	Distortion		F	
3.3.2.4	Total Power Output		X	
3.3.2.4.1	Transient Response Time		F	
3.3.2.5	Current Output		X	
3.3.2.6	Load Power Factor Range		X	
3.3.2.7	Overload Rating		X	
3.3.2.8	Automatic Transfer		X	
3.3.2.9	Phase Imbalance Operation		F	
3.3.2.10	Conversion Efficiency		F	
3.3.2.11	Input/Output Isolation	X		
3.4	Marking	X		
3.4.1	Connector Stamping	X		
3.5.1	Temperature		F	
3.5.2	Vibration		F	
3.5.3	Shock		F	
3.5.4	Humidity		F	
3.5.5	Altitude		F	
3.6.1	Organizational Level			F
3.6.2	Intermediate Level			F
3.7	MTBF			F
3.8	Equipment Manual	X		
3.9	Workmanship	X		

X = Both, First Article and Operational Burn-in test
 F = First Article only

THIS DOCUMENT HAS BEEN PURCHASED BY THE GOVERNMENT AND MAY BE REPRODUCED AND USED IN CONNECTION WITH ANY GOVERNMENT PROCUREMENT OR MAINTENANCE OPERATION. S-1	SIZE	FSCM NO.	DRAWING NO.	
	A	80063	A3093580	
	SCALE	NONE	N	SHEET 15

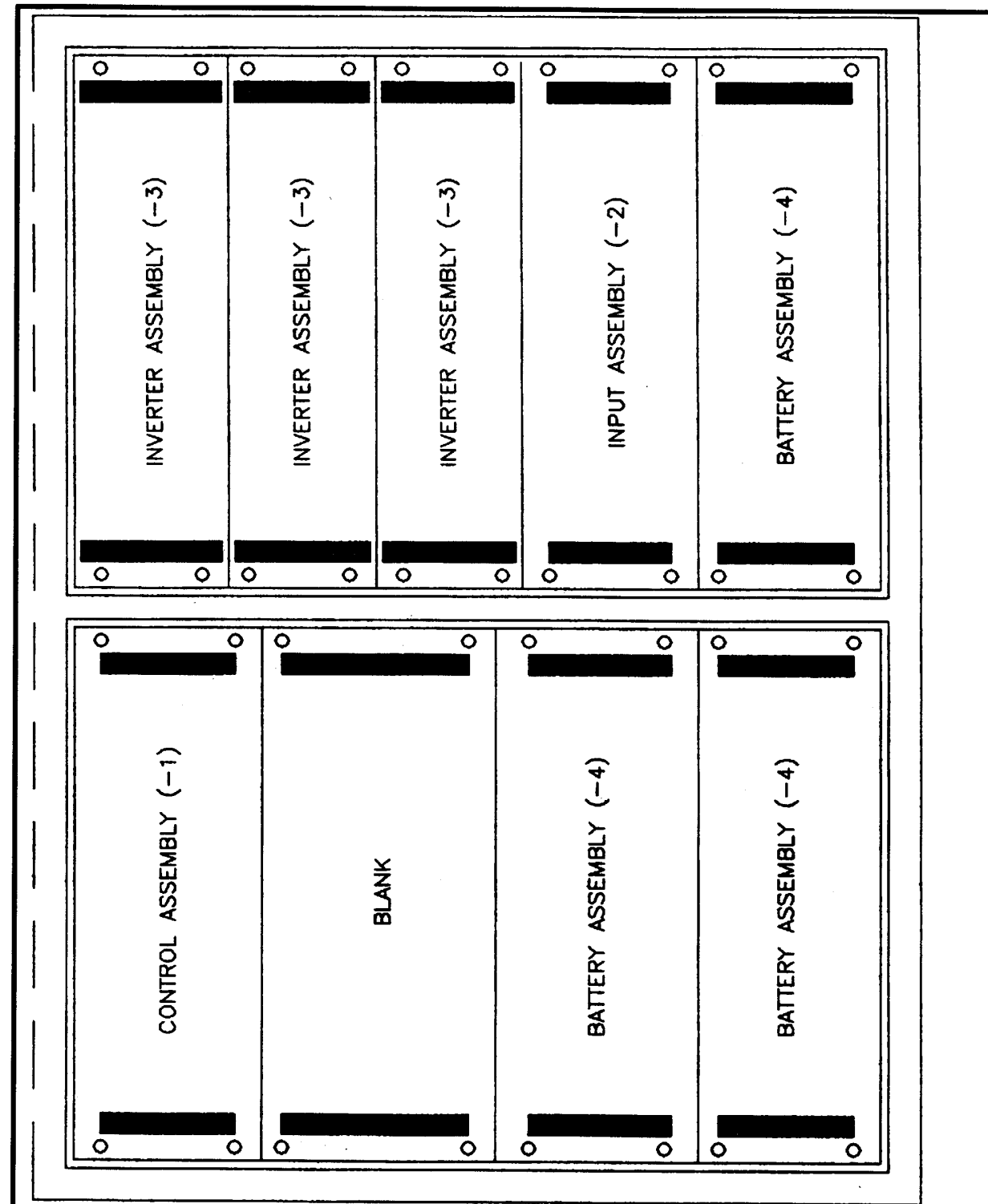

THIS DOCUMENT HAS BEEN PURCHASED BY THE GOVERNMENT AND MAY BE REPRODUCED AND USED IN CONNECTION WITH ANY GOVERNMENT PROCUREMENT OR MAINTENANCE OPERATION. S-1	SIZE	FSCM NO.	DRAWING NO.	
	A	80063	A3093580	
	SCALE	NONE	N	SHEET 17

FIGURE 1 PANEL ARRANGEMENT

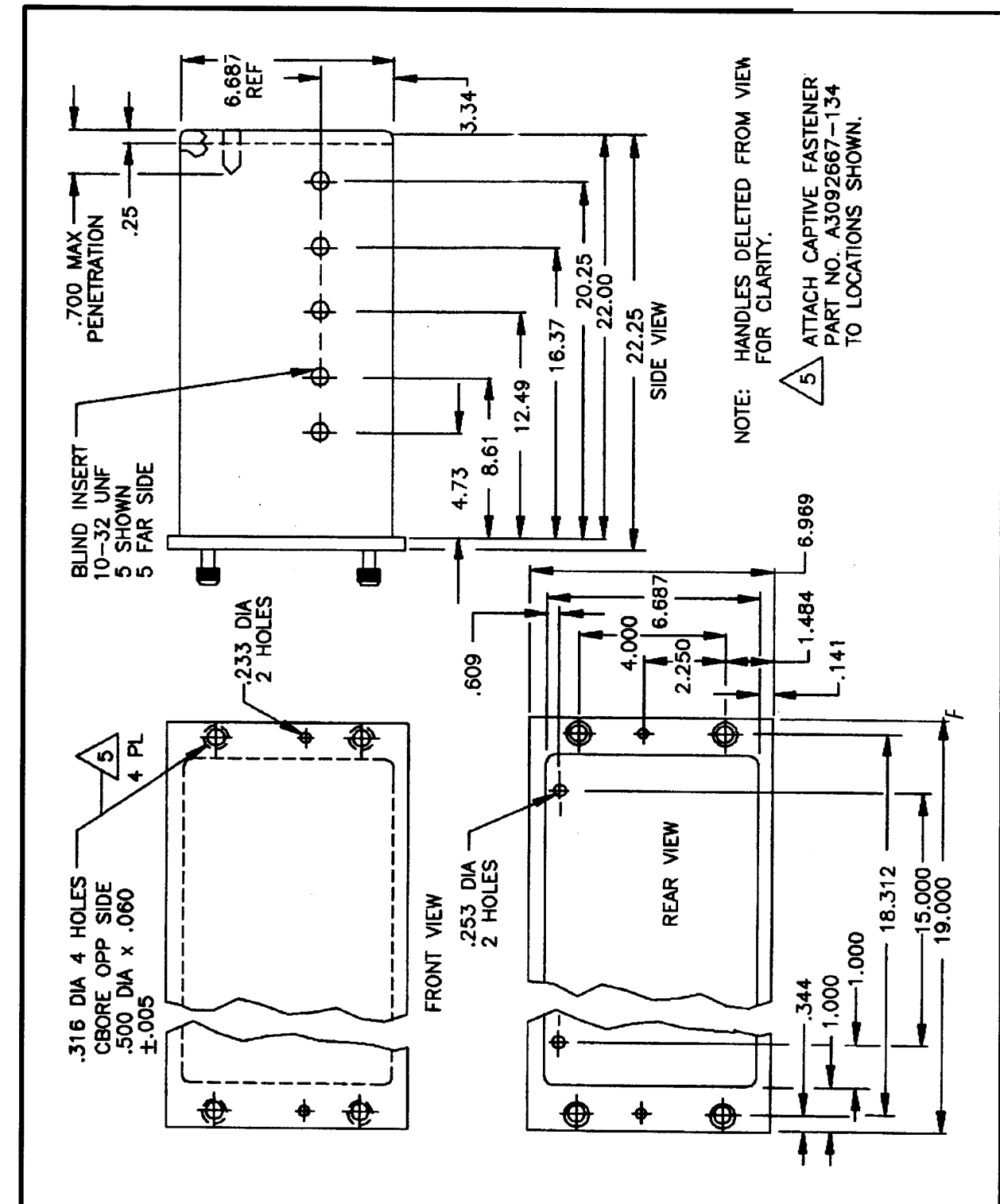

THIS DOCUMENT HAS BEEN PURCHASED BY THE GOVERNMENT AND MAY BE REPRODUCED AND USED IN CONNECTION WITH ANY GOVERNMENT PROCUREMENT OR MAINTENANCE OPERATION. S-1	SIZE	FSCM NO.	DRAWING NO.	
	A	80063	A3093580	
	SCALE	NONE	N	SHEET 18

FIGURE 2. CONTROL ASSEMBLY (-1), PANEL CHASSIS

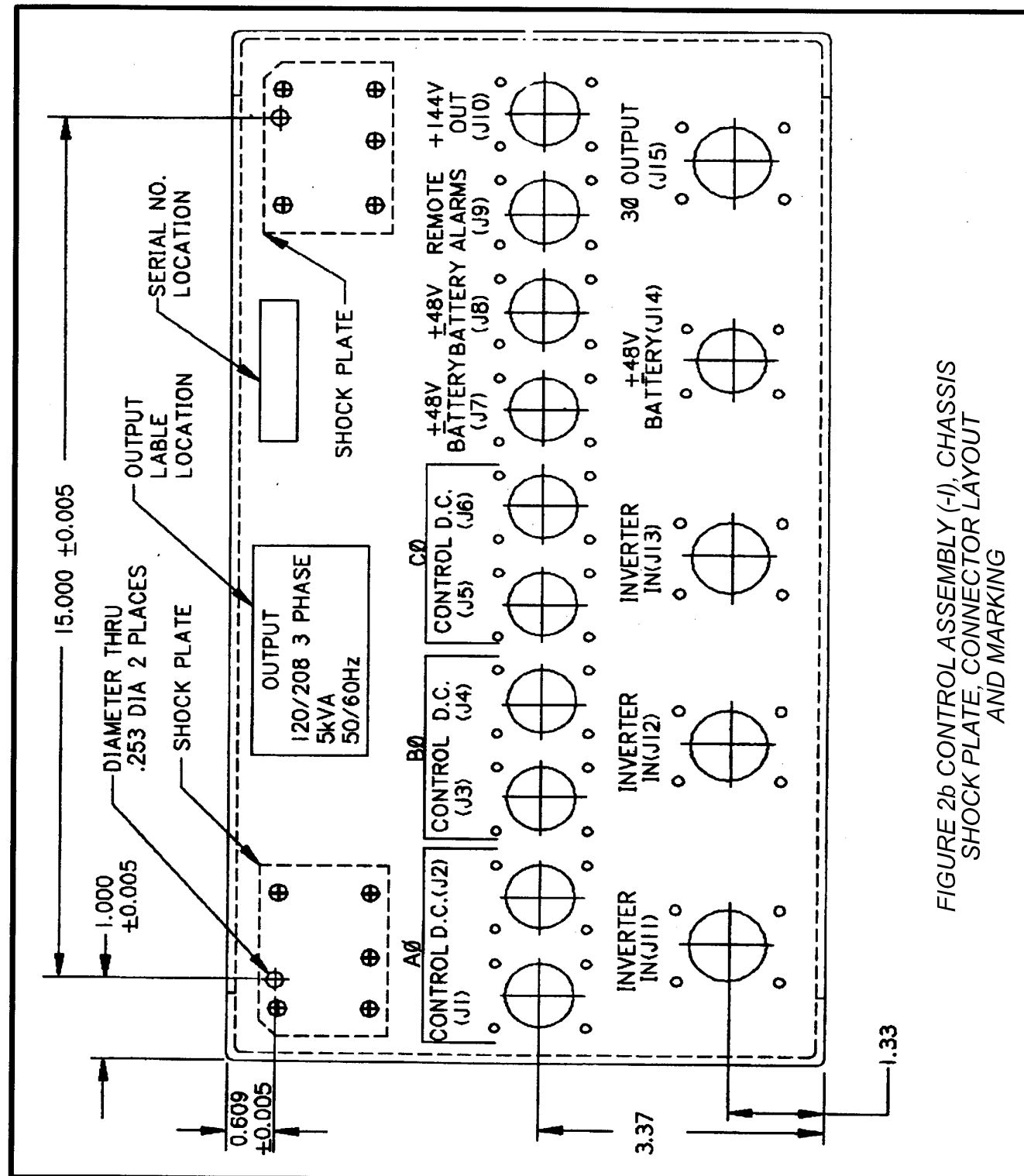
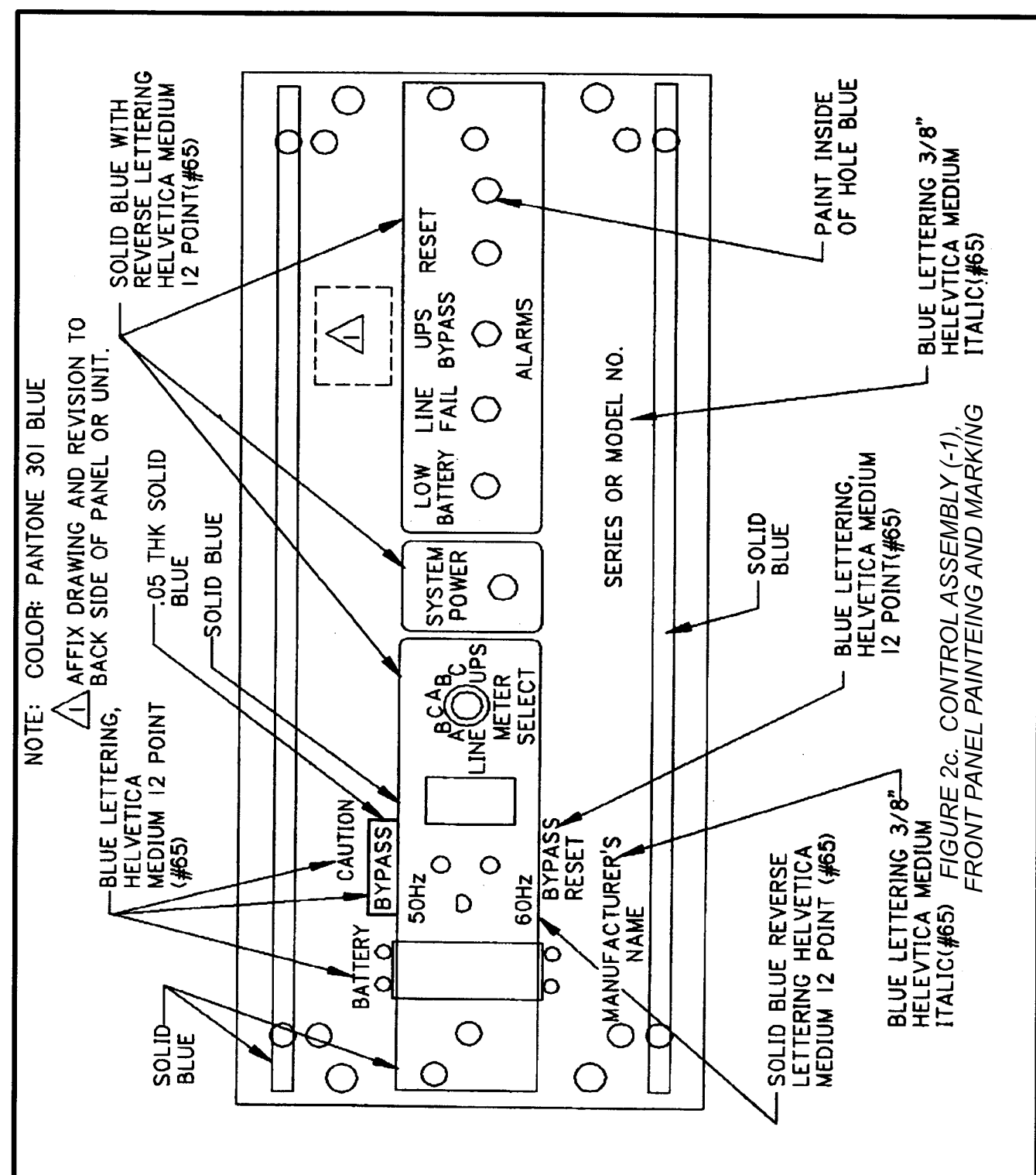

FIGURE 2b CONTROL ASSEMBLY (-1), CHASSIS SHOCK PLATE, CONNECTOR LAYOUT AND MARKING

THIS DOCUMENT HAS BEEN PURCHASED BY THE GOVERNMENT AND MAY BE REPRODUCED AND USED IN CONNECTION WITH ANY GOVERNMENT PROCUREMENT OR MAINTENANCE OPERATION. S-1	SIZE	FSCM NO.	DRAWING NO.	
	A	80063	A3093580	
	SCALE	NONE	REV N	SHEET 19



NOTE: COLOR: PANTONE 301 BLUE
 ⚠ AFFIX DRAWING AND REVISION TO BACK SIDE OF PANEL OR UNIT.

THIS DOCUMENT HAS BEEN PURCHASED BY THE GOVERNMENT AND MAY BE REPRODUCED AND USED IN CONNECTION WITH ANY GOVERNMENT PROCUREMENT OR MAINTENANCE OPERATION. S-1	SIZE	FSCM NO.	DRAWING NO.	
	A	80063	A3093580	
	SCALE	NONE	REV N	SHEET 20

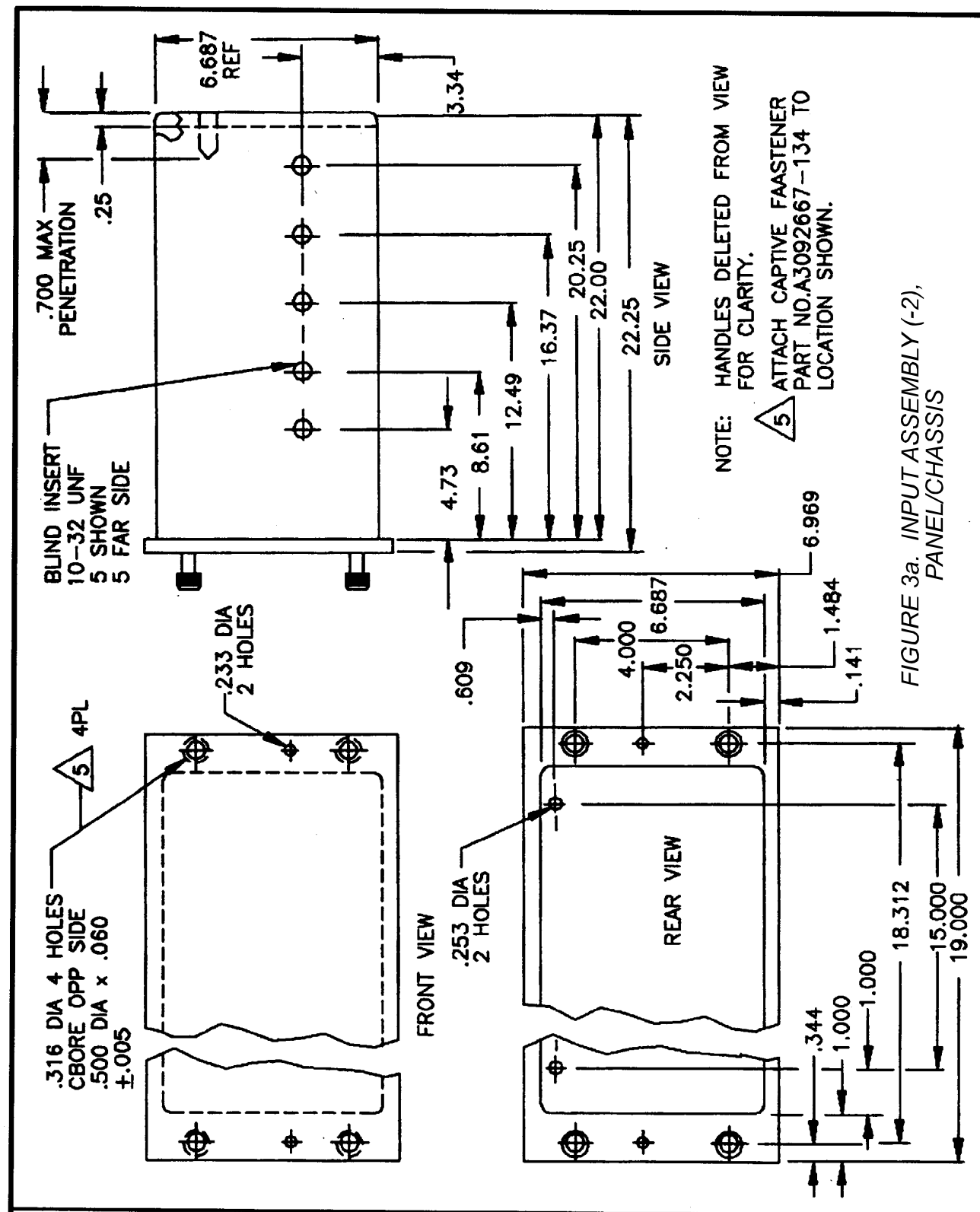

NOTE: HANDLES DELETED FROM VIEW FOR CLARITY.
 5 ATTACH CAPTIVE FASTENER PART NO. A3092667-134 TO LOCATION SHOWN.

FIGURE 3a. INPUT ASSEMBLY (-2), PANEL/CHASSIS

THIS DOCUMENT HAS BEEN PURCHASED BY THE GOVERNMENT AND MAY BE REPRODUCED AND USED IN CONNECTION WITH ANY GOVERNMENT PROCUREMENT OR MAINTENANCE OPERATION. S-1	SIZE	FSCM NO.	DRAWING NO.	
	A	80063	A3093580	
	SCALE	NONE	REV	N SHEET 21

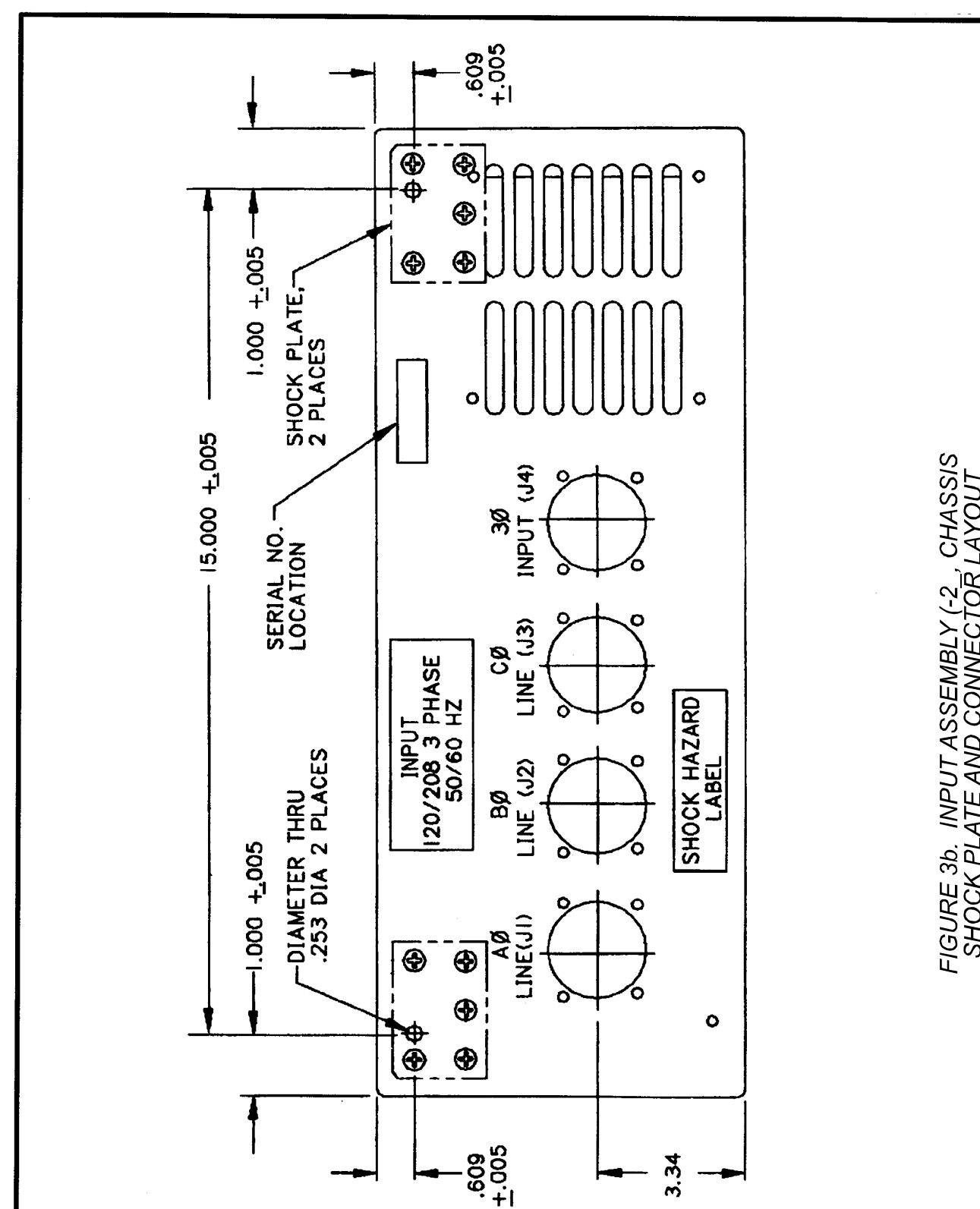
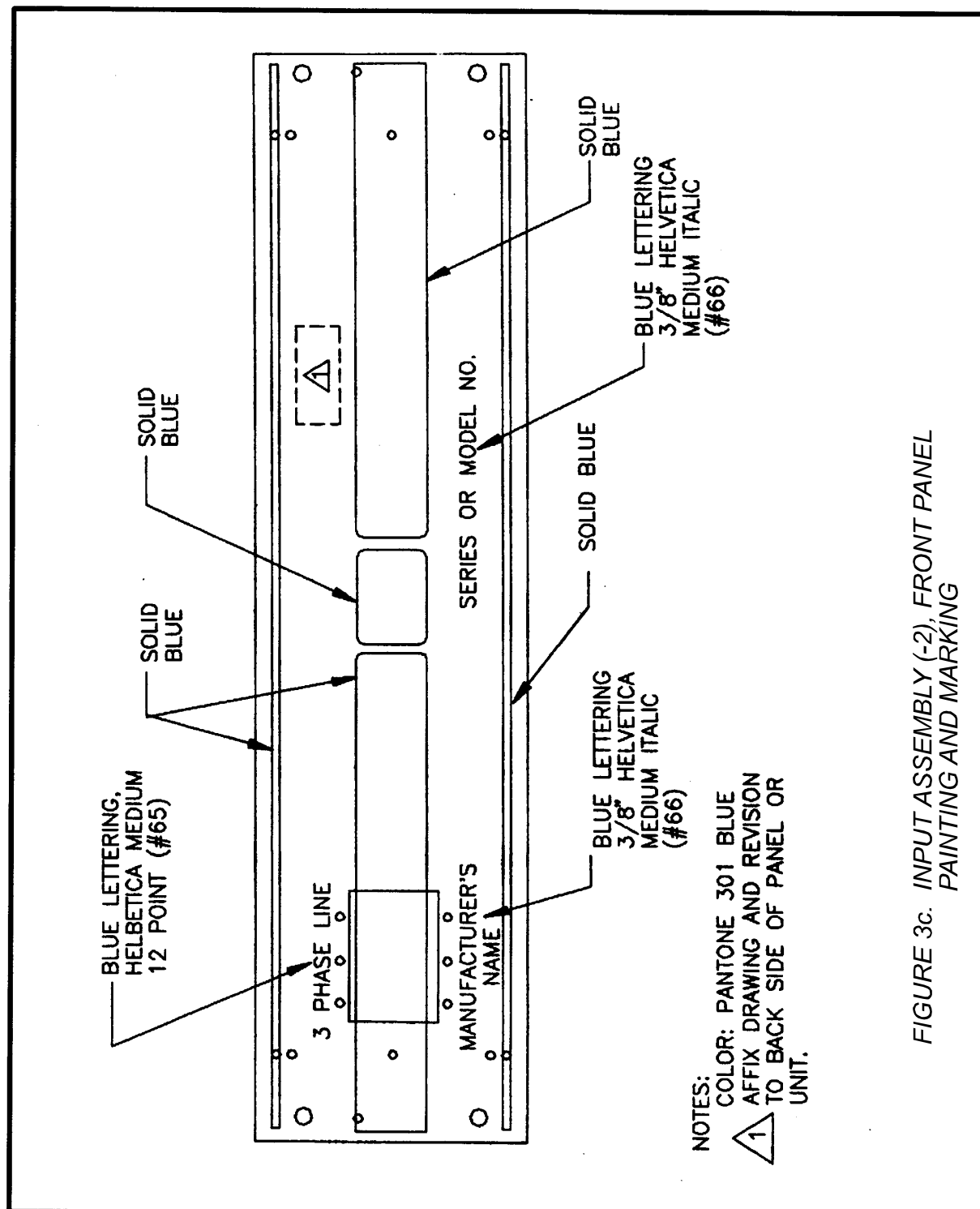

FIGURE 3b. INPUT ASSEMBLY (-2), CHASSIS SHOCK PLATE AND CONNECTOR LAYOUT

THIS DOCUMENT HAS BEEN PURCHASED BY THE GOVERNMENT AND MAY BE REPRODUCED AND USED IN CONNECTION WITH ANY GOVERNMENT PROCUREMENT OR MAINTENANCE OPERATION. S-1	SIZE	FSCM NO.	DRAWING NO.	
	A	80063	A3093580	
	SCALE	NONE	REV	N SHEET 22



NOTES:
 1 COLOR: PANTONE 301 BLUE
 AFFIX DRAWING AND REVISION TO BACK SIDE OF PANEL OR UNIT.

FIGURE 3c. INPUT ASSEMBLY (-2), FRONT PANEL PAINTING AND MARKING

THIS DOCUMENT HAS BEEN PURCHASED BY THE GOVERNMENT AND MAY BE REPRODUCED AND USED IN CONNECTION WITH ANY GOVERNMENT PROCUREMENT OR MAINTENANCE OPERATION. S-1	SIZE	FSCM NO.	DRAWING NO.		
	A	80063	A3093580		
SCALE	NONE	REV	N	SHEET	23

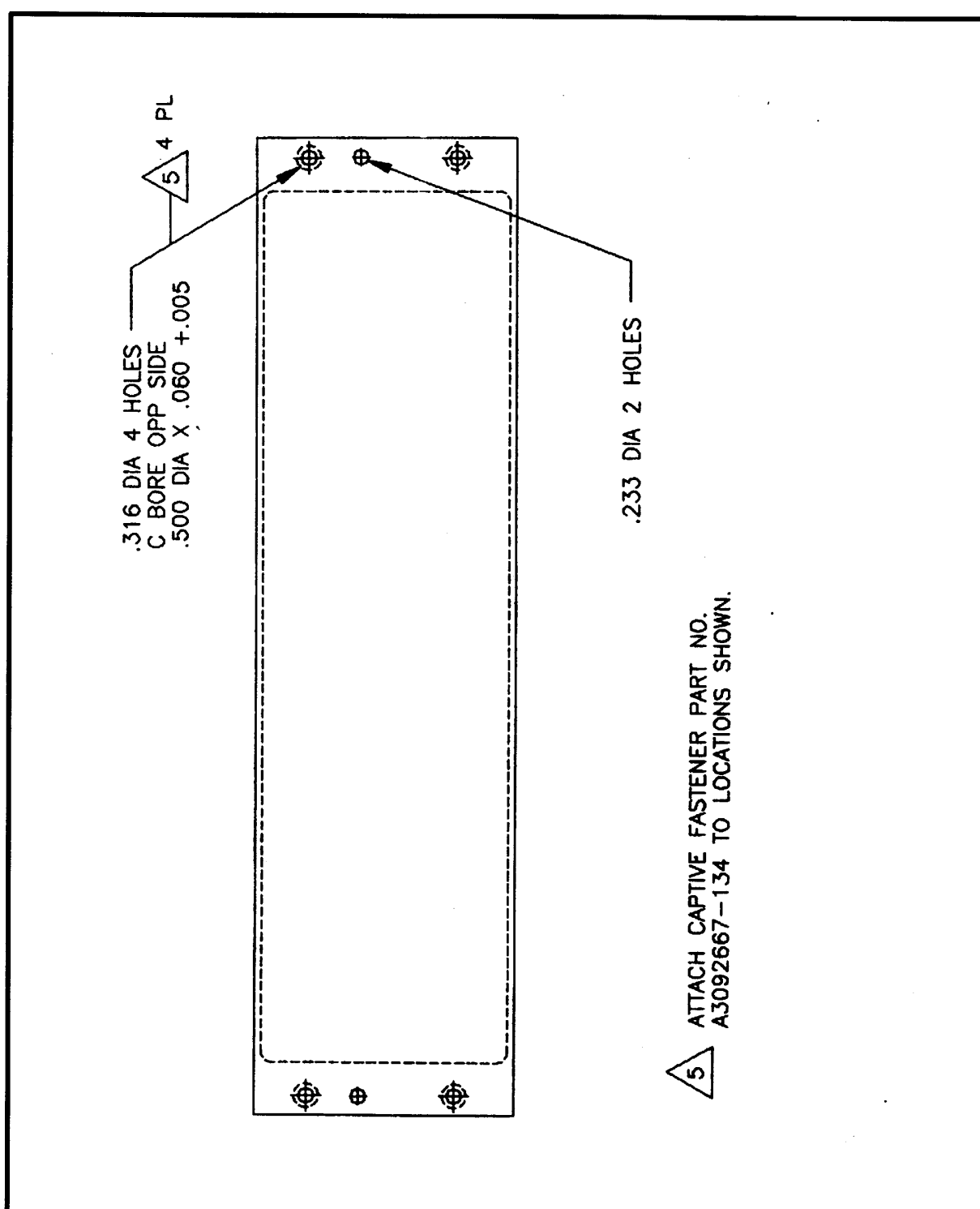

5 ATTACH CAPTIVE FASTENER PART NO. A3092667-134 TO LOCATIONS SHOWN.

FIGURE 4a. INVERTER ASSEMBLY (-3), PANEL/CHASSIS

THIS DOCUMENT HAS BEEN PURCHASED BY THE GOVERNMENT AND MAY BE REPRODUCED AND USED IN CONNECTION WITH ANY GOVERNMENT PROCUREMENT OR MAINTENANCE OPERATION. S-1	SIZE	FSCM NO.	DRAWING NO.		
	A	80063	A3093580		
SCALE	NONE	REV	N	SHEET	24

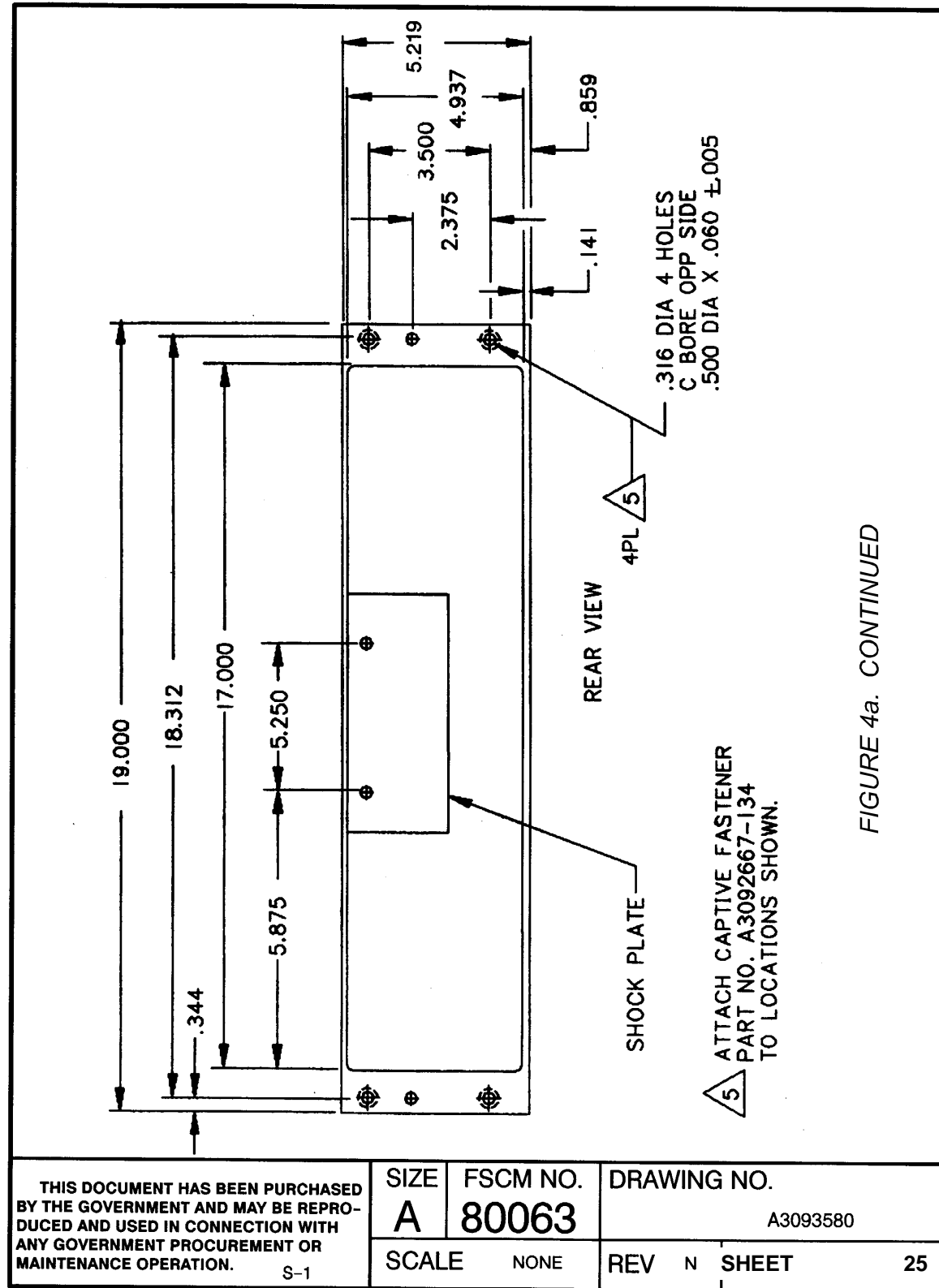

FIGURE 4a. CONTINUED

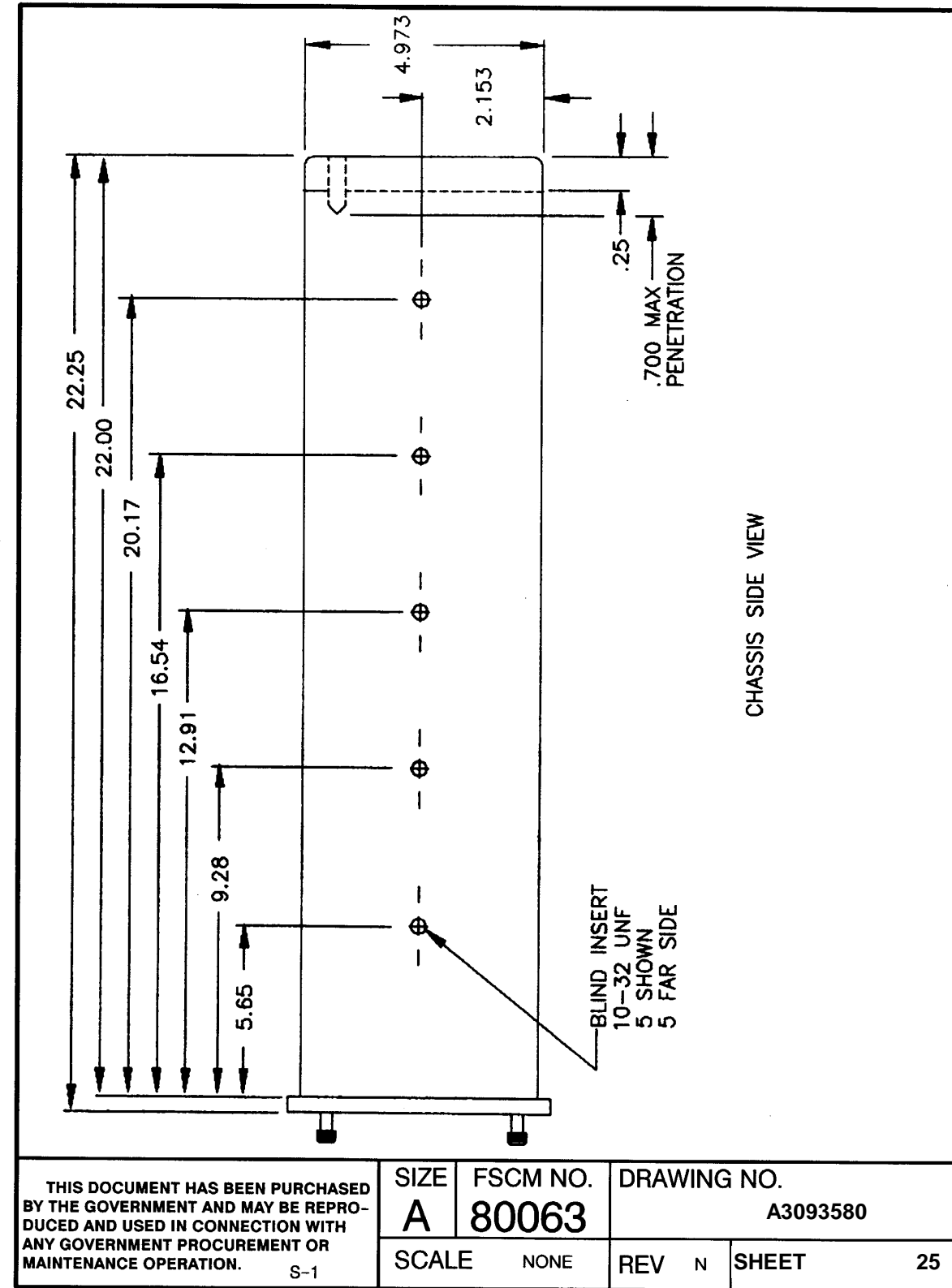
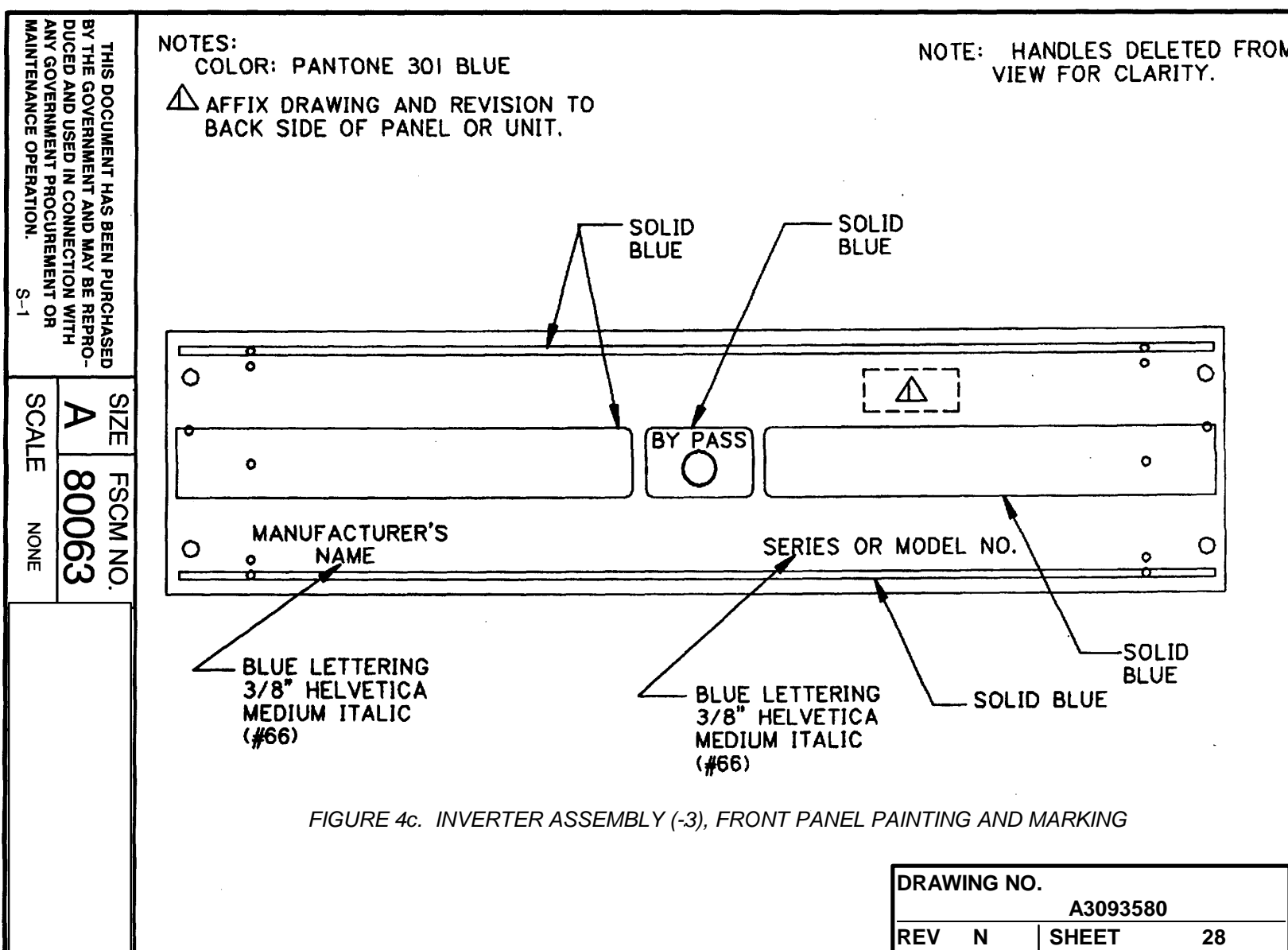
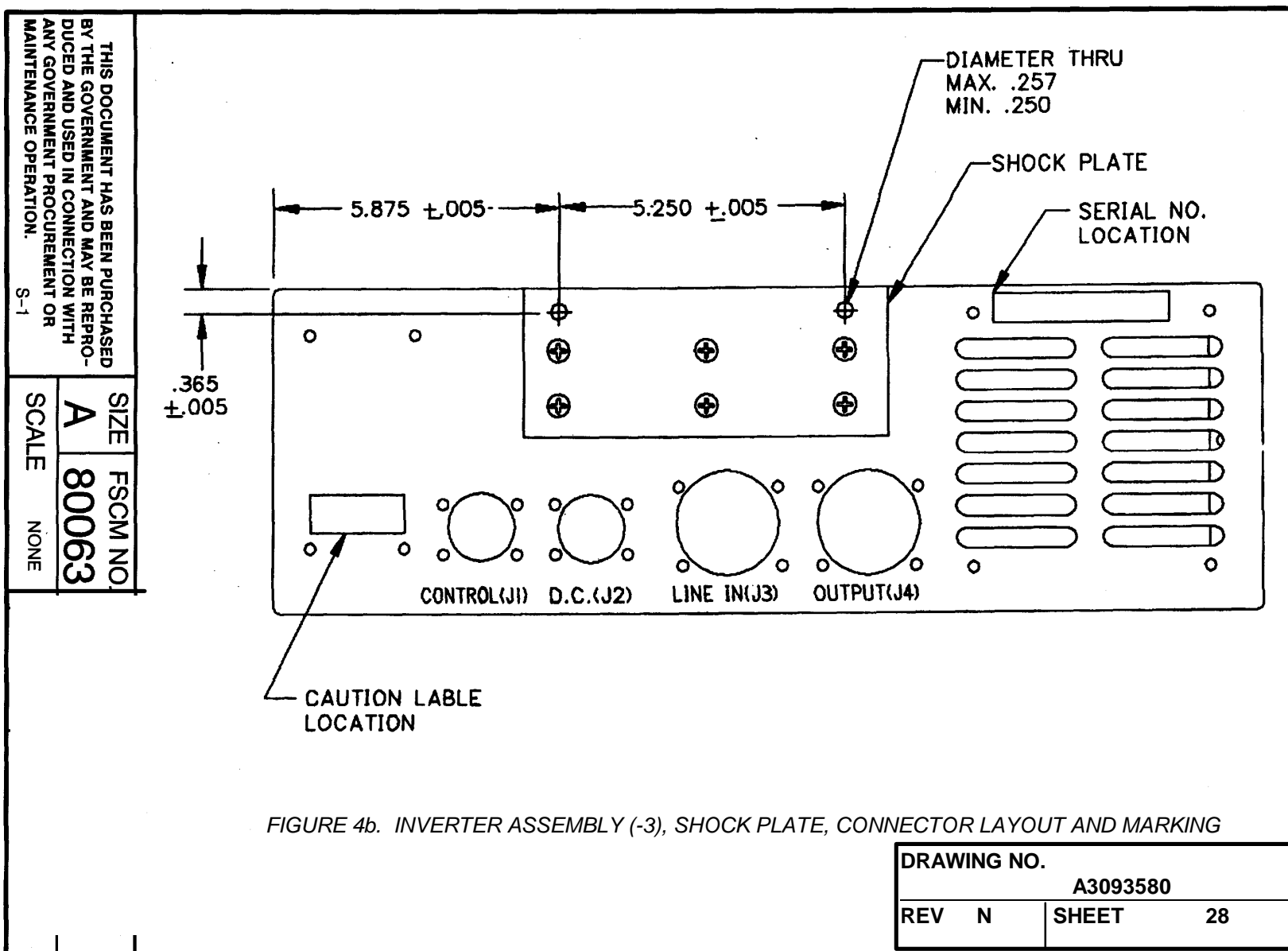
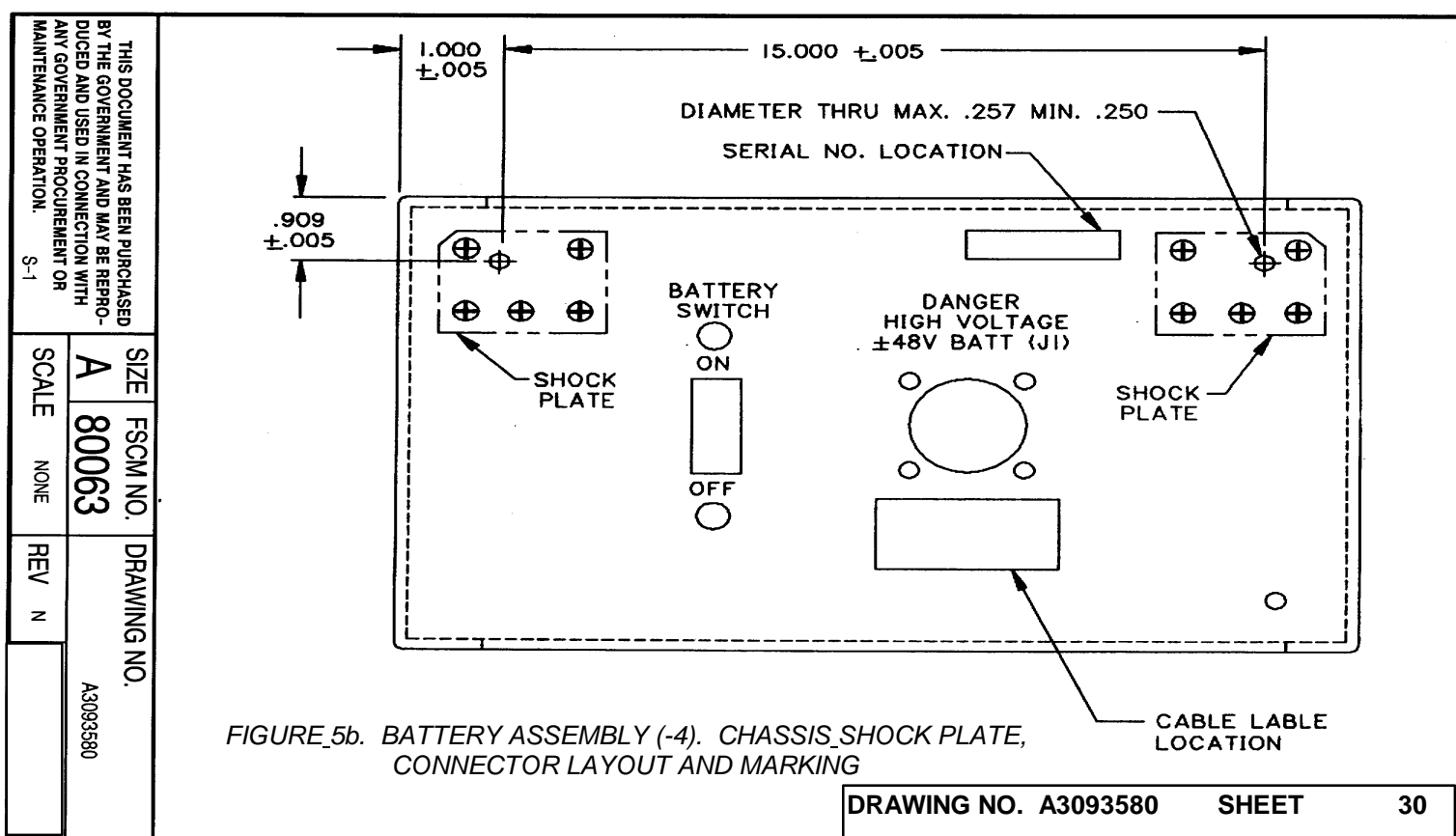
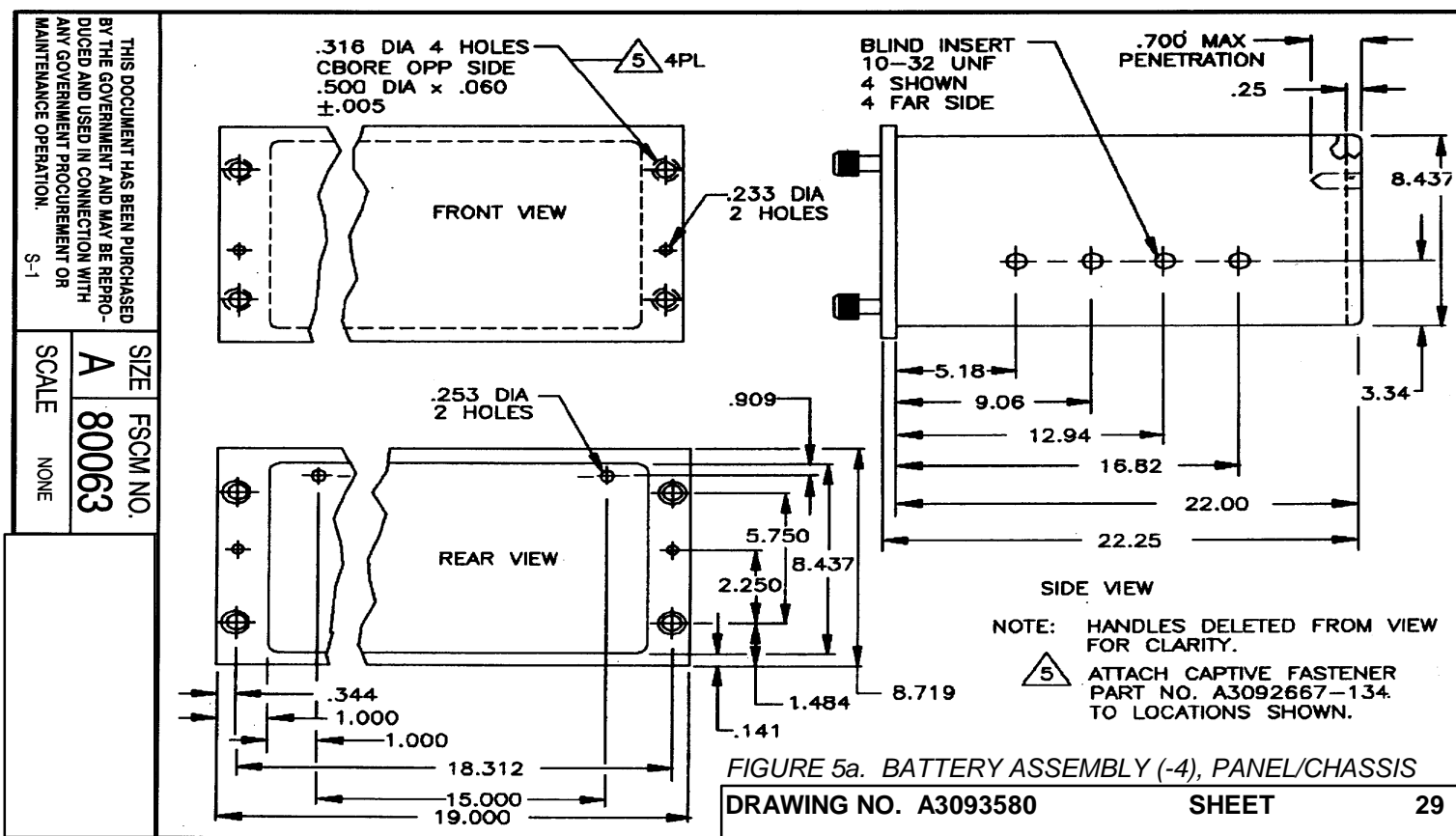

FIGURE 4a. CONTINUED





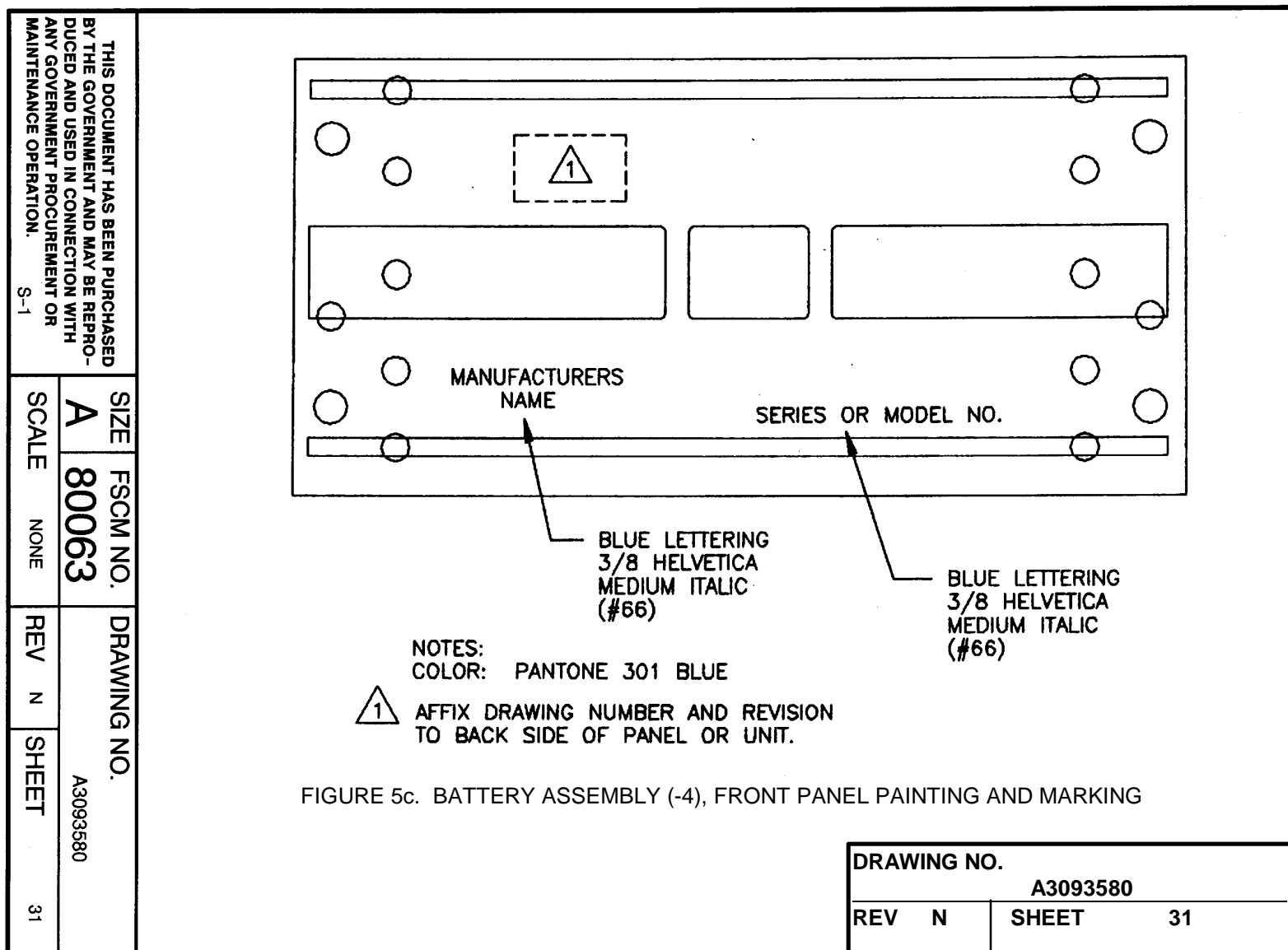

FIGURE 5c. BATTERY ASSEMBLY (-4), FRONT PANEL PAINTING AND MARKING

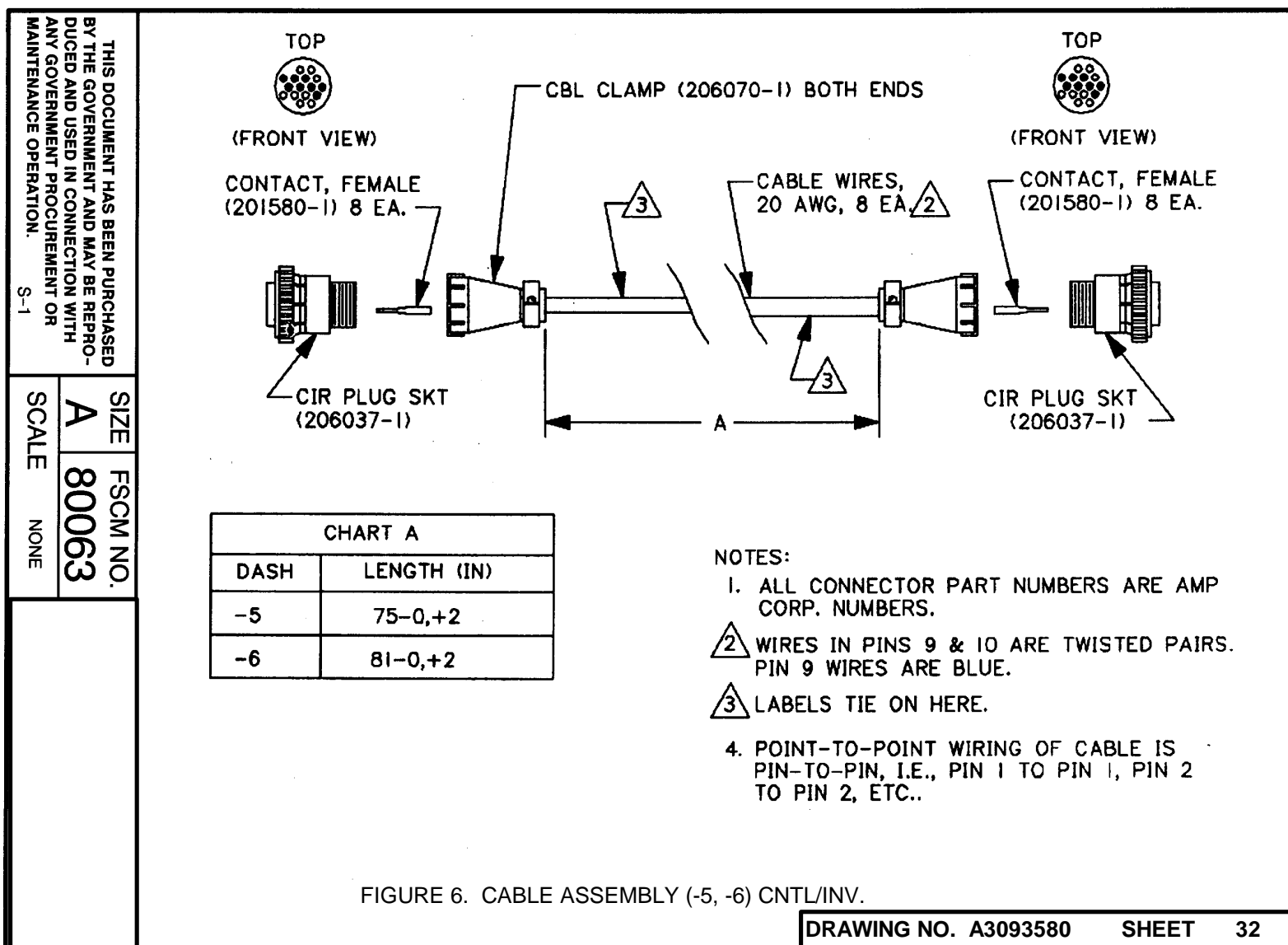
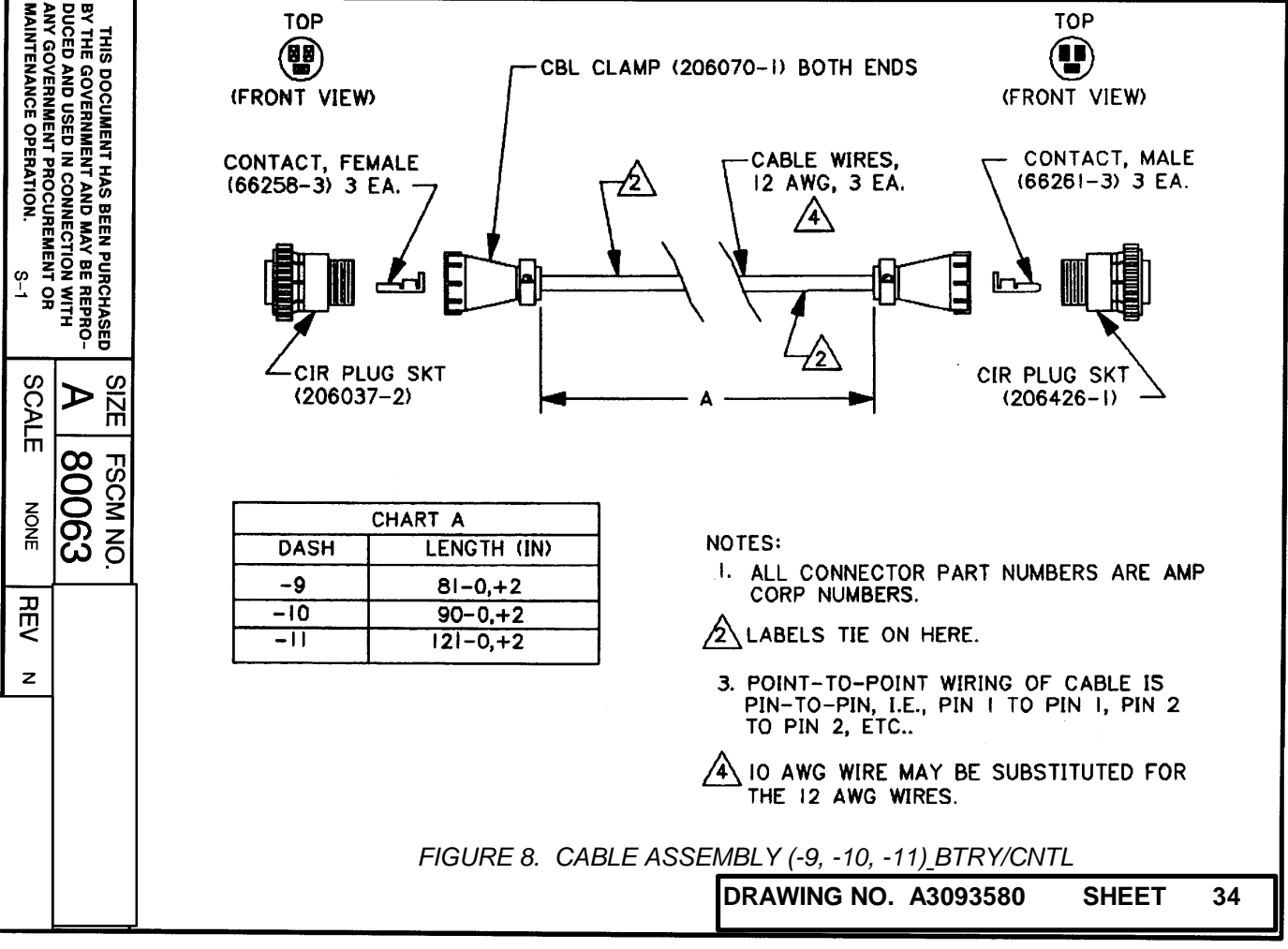
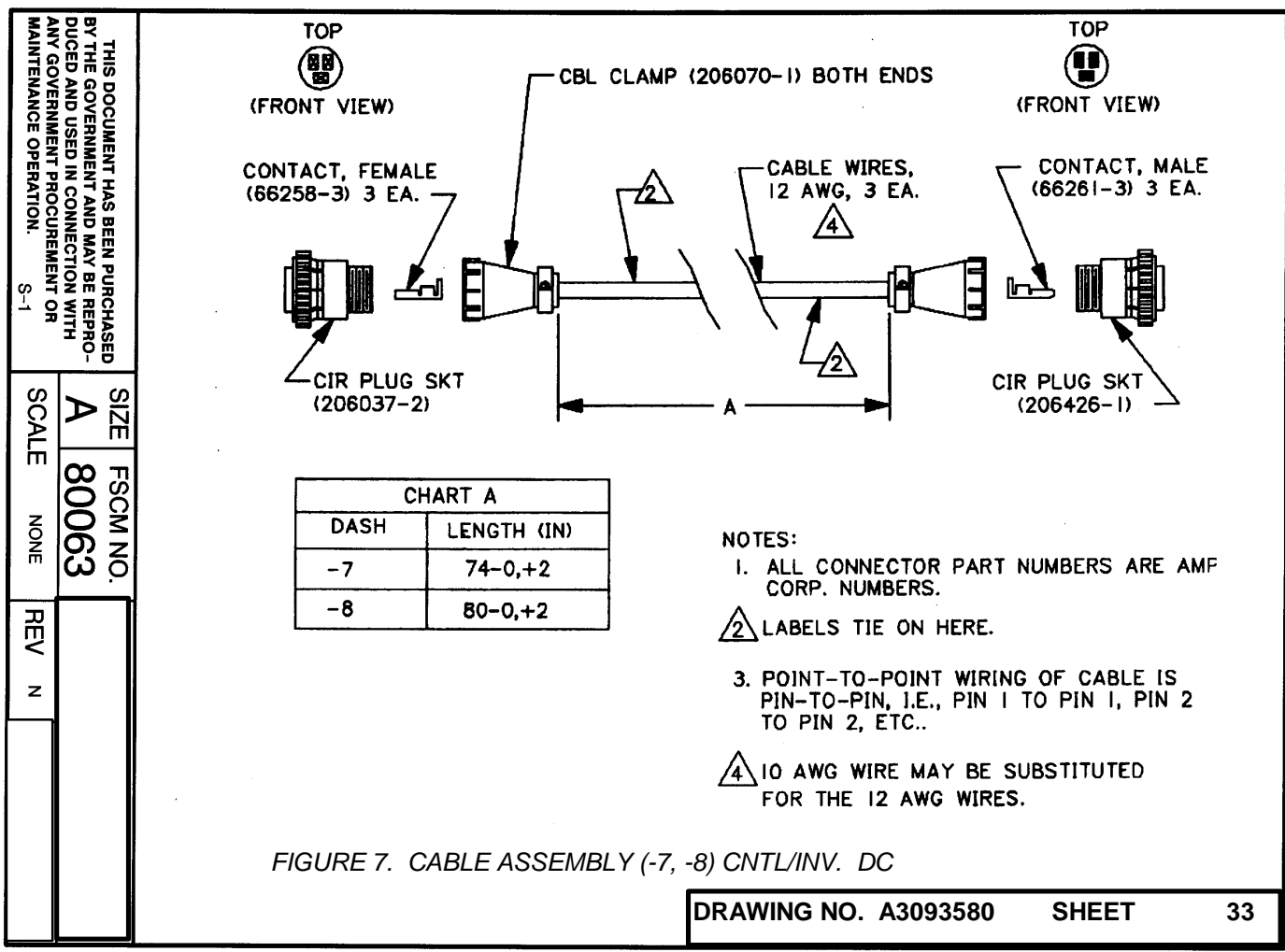
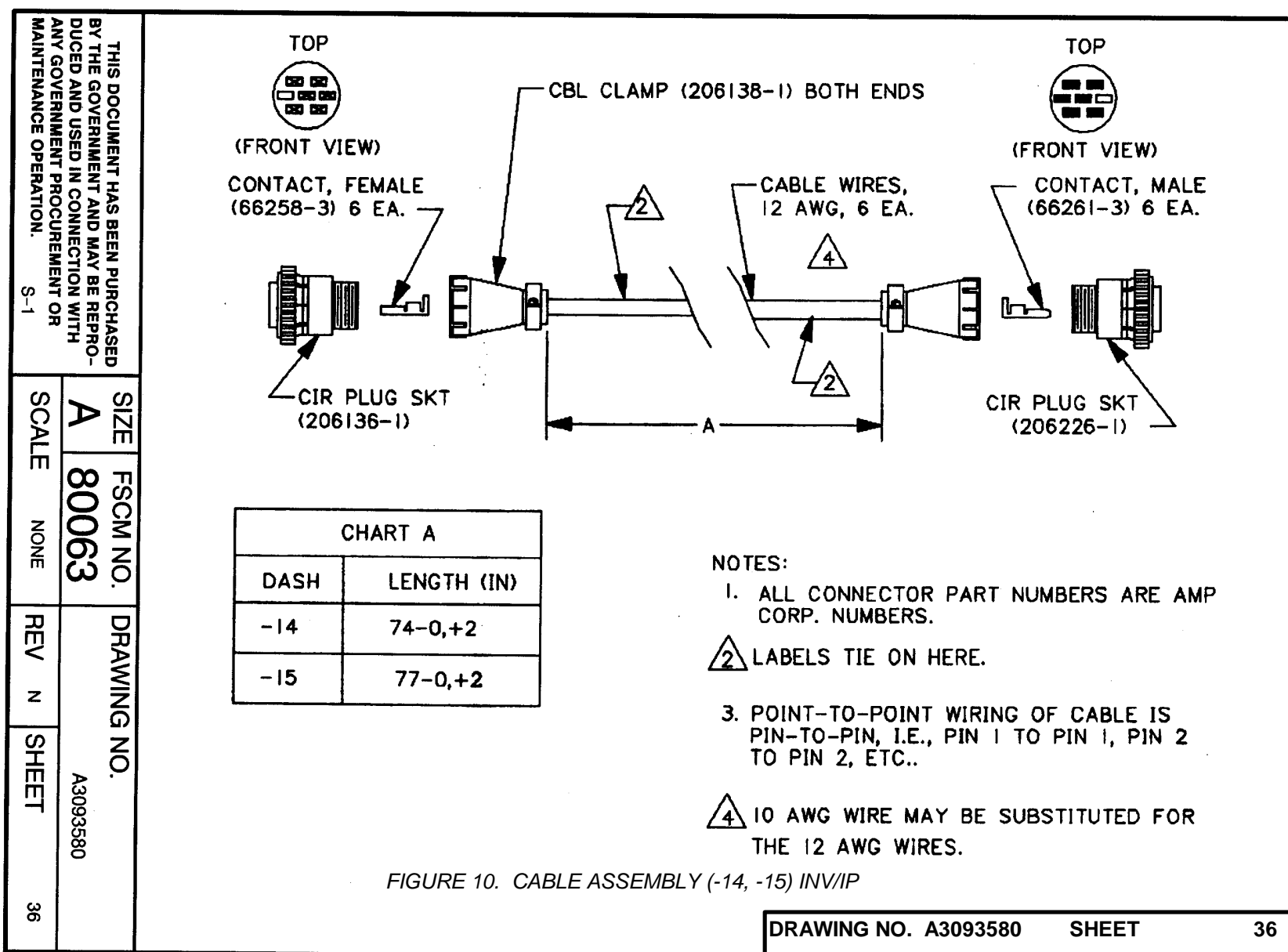
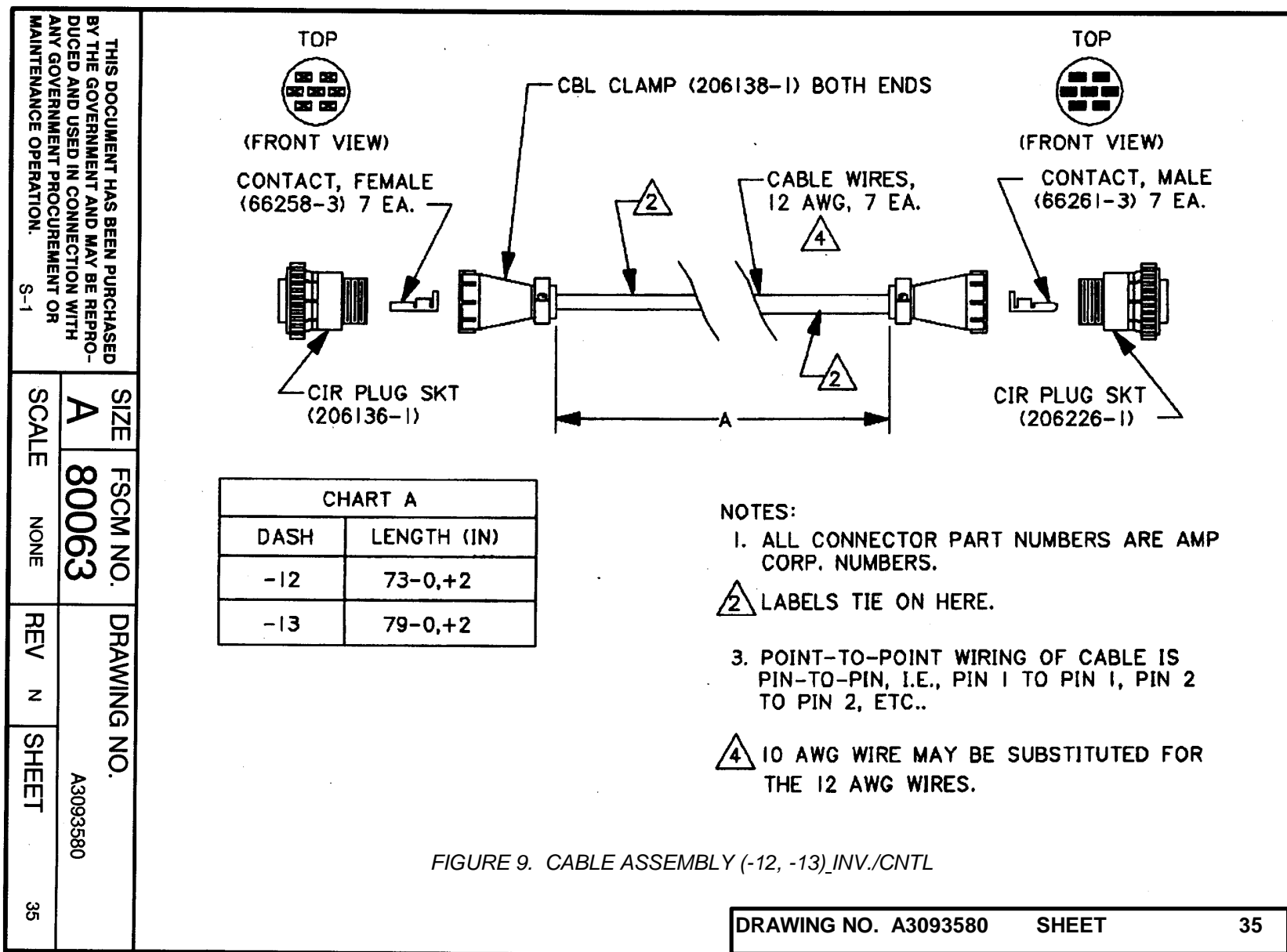

FIGURE 6. CABLE ASSEMBLY (-5, -6) CNTL/INV.





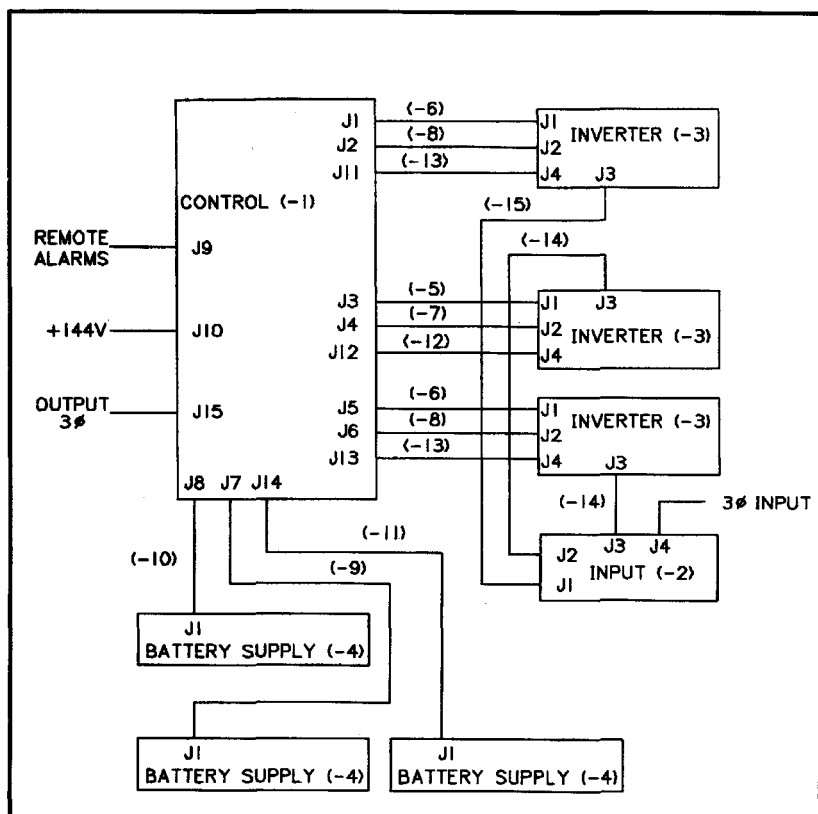

FIGURE 11. BLOCK DIAGRAM

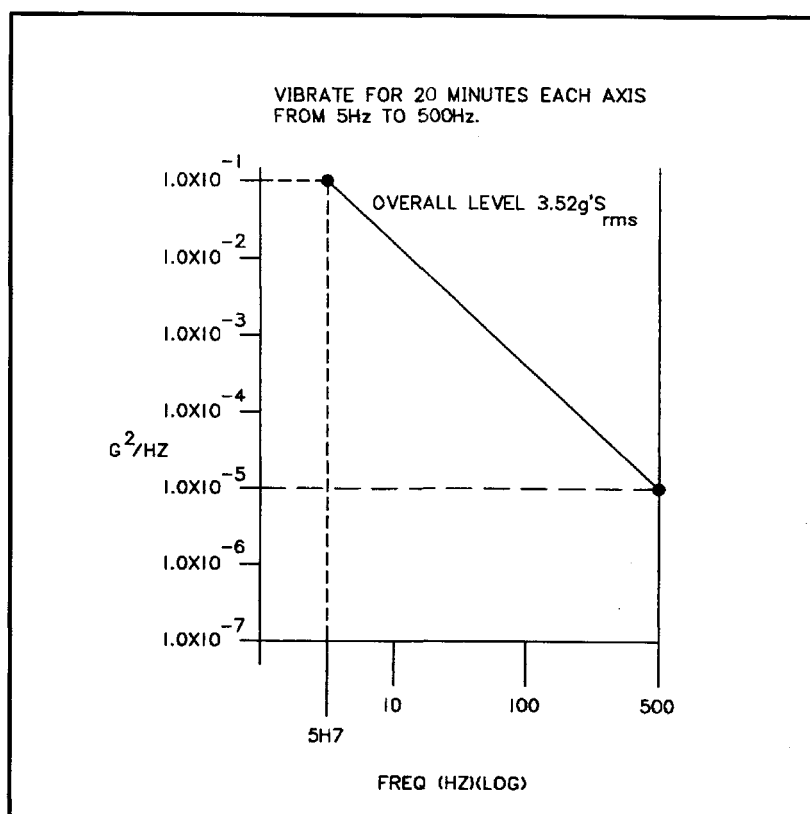

FIGURE 12. UPS VIBRATION CURVE

THIS DOCUMENT HAS BEEN PURCHASED BY THE GOVERNMENT AND MAY BE REPRODUCED AND USED IN CONNECTION WITH ANY GOVERNMENT PROCUREMENT OR MAINTENANCE OPERATION. S-1	SIZE	FSCM NO.	DRAWING NO.
	A	80063	A3093580
SCALE	NONE	REV N	SHEET 37

THIS DOCUMENT HAS BEEN PURCHASED BY THE GOVERNMENT AND MAY BE REPRODUCED AND USED IN CONNECTION WITH ANY GOVERNMENT PROCUREMENT OR MAINTENANCE OPERATION. S-1	SIZE	FSCM NO.	DRAWING NO.
	A	80063	A3093580
SCALE	NONE	REV N	SHEET 38

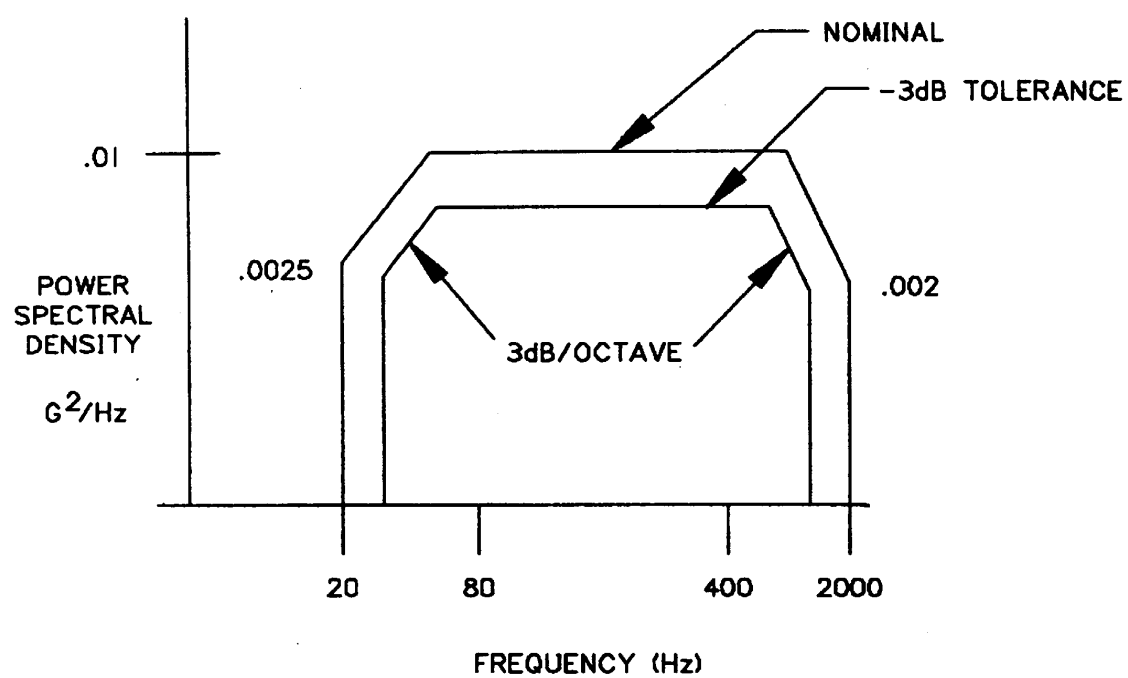

FIGURE 13. UPS BURN IN VIBRATION CURVE

THIS DOCUMENT HAS BEEN PURCHASED BY THE GOVERNMENT AND MAY BE REPRODUCED AND USED IN CONNECTION WITH ANY GOVERNMENT PROCUREMENT OR MAINTENANCE OPERATION. S-1	SIZE	FSCM NO.	DRAWING NO.	
	A	80063	A3093580	
SCALE	NONE	N	SHEET	39

POWER SOURCE, UNINTERRUPTIBLE, AC TO DC TO AC, 3 PHASE, 5 KVA OUT (UPS)
(Sheet 39 of 39)

NOTES :

1. IDENTIFY PART PER MIL-STD-130, TAG.
2. WORKMANSHIP SHALL BE IN ACCORDANCE WITH MIL-STD-454, REQUIREMENT 9.
3. DIMENSIONAL DATA IS BASED ON AMERICAN NATIONAL STANDARD ANSI Y14.5-1973.
4. CRIMP INSERTION TOOL NO. M81969/17-03, REMOVAL TOOL NO. M81969/19-07, PER MIL-I-81969.
5. CRIMPING TOOL NO. M22520/1-10 WITH M22520/1-02 TURRET, PER MIL-C-22520.
6. EACH CONDUCTOR SHALL BE TESTED FOR CONTINUITY AND CORRECT CONNECTIONS BETWEEN ITS TERMINATIONS, USING A POTENTIAL OF NOT MORE THAN 10 VOLTS. CONTINUITY CHECKS SHALL BE MADE FROM CONNECTOR CONTACT TO CONNECTOR CONTACT USING A CONTINUITY TESTER. CONTINUITY POINTS SHALL BE OBTAINED FROM THE CABLE WIRING DIAGRAM. WHERE SHIELD IS BONDED TO CONNECTOR ON BOTH ENDS, THE SHIELD CONTINUITY SHALL BE CHECKED FROM CONNECTOR SHELL TO CONNECTOR SHELL.
7. INSULATION RESISTANCE SHALL BE IN ACCORDANCE WITH METHOD 302 OF MIL-STD-202, TEST CONDITION B. THE POTENTIAL SHALL BE APPLIED BETWEEN EACH CONDUCTOR AND THE REMAINING CONDUCTORS CONNECTED TOGETHER AND TO THE SHIELD, AND CONNECTOR. THE INSULATION RESISTANCE OF THE CABLE ASSEMBLY SHALL NOT BE LESS THAN 100 MEGOHMS. EXCEPT THE INSULATION RESISTANCE OF A SHIELDED CONDUCTOR SHALL NOT BE LESS THAN 30 MEGOHMS.

8. DIELECTRIC WITHSTAND VOLTAGE. DIELECTRIC STRENGTH SHALL BE PERFORMED IN ACCORDANCE WITH METHOD 301 OF MIL-STD-202. A POTENTIAL OF 500 VOLTS DC SHALL BE APPLIED FOR 30 SECONDS MINIMUM. THE POTENTIAL SHALL BE APPLIED BETWEEN EACH CONDUCTOR AND THE REMAINING CONDUCTORS CONNECTED TOGETHER AND TO THE SHIELD AND CONNECTOR.

9. PARTIAL REFERENCE DESIGNATION ARE SHOWN. FOR COMPLETE REFERENCE DESIGNATION, PREFIX WITH UNIT NUMBER AND SUBASSEMBLY DESIGNATION.

10. SOLDERING SHALL BE IN ACCORDANCE WITH MIL-STD-454, REQUIREMENT 5.

⚠ DIMENSION B (RANGE 1/4 TO 1/2) AND DIMENSION C (RANGE 1/2 TO 3/4) CAN INCREASE OR DECREASE PROPORTIONALLY TO ALLOW SOLDER FERRULE PLACEMENT TO BE VARIED.

- ⚠2 INSTALL FERRULES ON SHIELDED TWISTED PAIRS AND SINGLE SHIELDED WIRE STARTING, 1/2 INCH FROM END OF CONNECTOR, SO FERRULES WILL NOT TERMINATE AT SAME LOCATION.
- ⚠3 WHEN BACKSHELL'S DIA IS TOO SMALL TO CONTAIN INDIVIDUAL FERRULES IT IS PERMISSIBLE TO TERMINATE 2 SHIELDED WIRES IN THE SAME FERRULE.
- ⚠4 ALL SHIELDS MUST TERMINATE INSIDE OF EMI BACKSHELL.
- ⚠5 ALL UNUSED POSITIONS IN CONNECTORS P1 & P2 ARE TO BE FILLED WITH CONTACTS.
16. QUANTITY SHOWN IS IN INCHES.
- ⚠7 TOLERANCE ON CABLE LENGTH SHALL BE +2,-1 INCHES.
- ⚠8 DIMENSIONS SHOWN ON CABLE PREPARATION ILLUSTRATION ARE FOR REFERENCE ONLY.
- ⚠9 PLACE HEAT SHRINK SLEEVING, ITEM 8, UNDER SOLDER FERRULE TO PROTECT WIRING.
- ⚠0 VENDOR ITEM-SEE SPECIFICATION CONTROL DRAWING.

2	12	96906	MS3126F12-109	CONNECTOR, ELECTRICAL, PLUG			
	11						
20	10	81349	M39029/32-259	CONTACT, CRIMP, SOCKET	MIL-C-39029/32		
	9						
2	8	81349	M23053/5-104-0	HEAT SHRINK SLEEVING	MIL-I-23053/5		16
	7						
	6						
REF	5	80063	A3092728	TEST PROCEDURE/DATA SHEET POWER AND SIGNAL CABLE TEST			
1	4	80063	A3093589-2	BACKSHELL, EMI/RFI			20
158	3	80063	A3093563-2	CABLE, ELECTRICAL, SPECIAL PURPOSE			16 , 20
2	2	80063	A3093335-1	FERRULE, SOLDER			20
1	1	80063	A3092984-3	BACKSHELL, EMI/RFI			20
QTY REQD	FIND NO.	FSCM NO.	PART NUMBER OR IDENTIFYING NO.	NOMENCLATURE OR DESCRIPTION	SPEC/STD	SHEET NO.	NOTE
PARTS LIST							

A3093582
Cable Assembly, LGM/Patch
(Sheet 1 of 2)

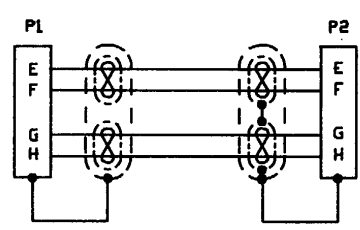
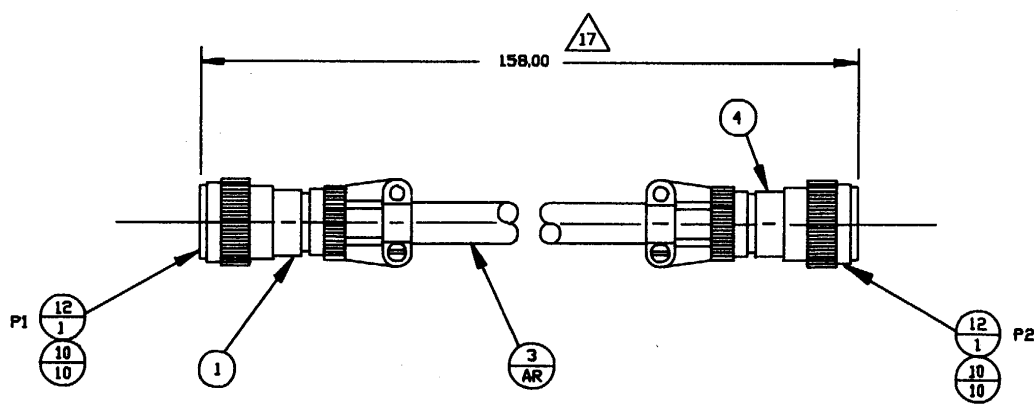

WIRING DIAGRAM

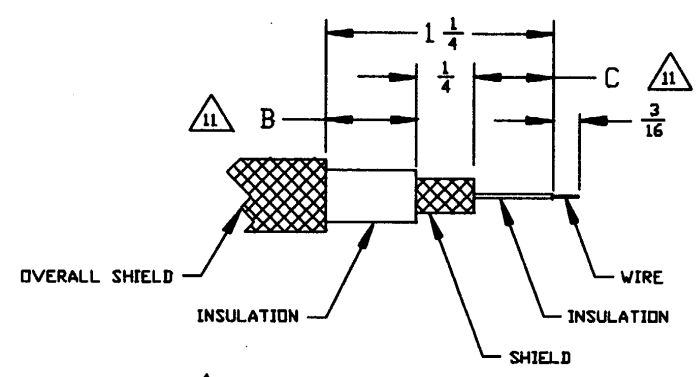
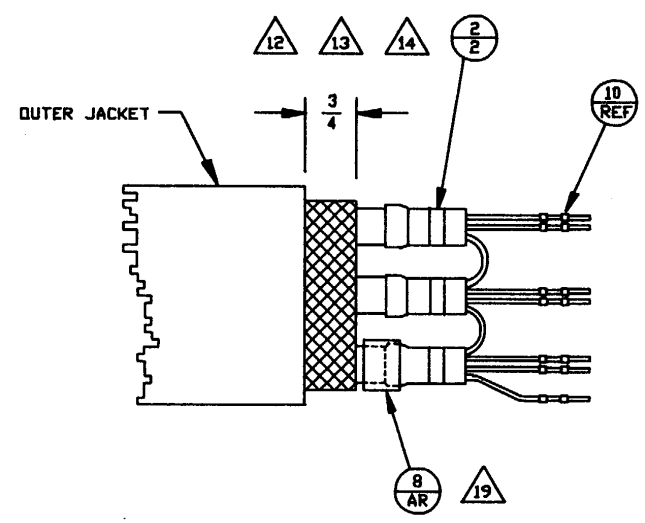





$\Delta 18$ CABLE PREPARATION

SCALE : 2/1
BOTH ENDS

A3093582

Cable Assembly, LGM/Patch
(Sheet 2 of 2)

NOTES :

1. IDENTIFY PART PER MIL-STD-130, TAG.
2. WORKMANSHIP SHALL BE IN ACCORDANCE WITH MIL-STD-454, REQUIREMENT 9.
3. DIMENSIONAL DATA IS BASED ON AMERICAN NATIONAL STANDARD ANSI Y14.5-1973.
4. CRIMP INSERTION TOOL NO. M81969/1-02, REMOVAL TOOL NO. M81969/1-02, PER MIL-1-81969.
5. CRIMPING TOOL NO. M22520/2-01 WITH M22520/2-08 TURRET, PER MIL-C-22520.
6. EACH CONDUCTOR SHALL BE TESTED FOR CONTINUITY AND CORRECT CONNECTIONS BETWEEN ITS TERMINATIONS, USING A POTENTIAL OF NOT MORE THAN 10 VOLTS. CONTINUITY CHECKS SHALL BE MADE FROM CONNECTOR CONTACT TO CONNECTOR CONTACT USING A CONTINUITY TESTER. CONTINUITY POINTS SHALL BE OBTAINED FROM THE CABLE WIRING DIAGRAM. WHERE SHIELD IS BONDED TO CONNECTOR ON BOTH ENDS, THE SHIELD CONTINUITY SHALL BE CHECKED FROM CONNECTOR SHELL TO CONNECTOR SHELL.
7. INSULATION RESISTANCE SHALL BE IN ACCORDANCE WITH METHOD 302 OF MIL-STD-202, TEST CONDITION B. THE POTENTIAL SHALL BE APPLIED BETWEEN EACH CONDUCTOR AND THE REMAINING CONDUCTORS CONNECTED TOGETHER AND TO THE SHIELD, AND CONNECTOR. THE INSULATION RESISTANCE OF THE CABLE ASSEMBLY SHALL NOT BE LESS THAN 100 MEGOHMS. EXCEPT THE INSULATION RESISTANCE OF A SHIELDED CONDUCTOR SHALL NOT BE LESS THAN 30 MEGOHMS.
8. DIELECTRIC WITHSTANDING VOLTAGE. DIELECTRIC STRENGTH SHALL BE PERFORMED IN ACCORDANCE WITH METHOD 301 OF MIL-STD-202. A POTENTIAL OF 500 VOLTS DC SHALL BE APPLIED FOR 30 SECONDS MINIMUM. THE POTENTIAL SHALL BE APPLIED BETWEEN EACH CONDUCTOR AND THE REMAINING CONDUCTORS CONNECTED TOGETHER AND TO THE SHIELD AND CONNECTOR.
9. PARTIAL REFERENCE DESIGNATIONS ARE SHOWN. FOR COMPLETE REFERENCE DESIGNATION, PREFIX WITH UNIT NUMBER AND SUBASSEMBLY DESIGNATION.
10. DELETED
11.  ALL UNUSED POSITIONS IN CONNECTORS P1 & P2 ARE TO BE FILLED WITH CONTACTS.
12. COMPLETE PART NUMBER FOR THIS ASSEMBLY SHALL INCLUDE APPLICABLE DASH NUMBER INDICATED IN QUANTITY REQUIRED COLUMN.
13. QUANTITY SHOWN IS IN INCHES.
14.  TOLERANCE ON CABLE LENGTH SHALL BE +2,-1 INCHES.
15.  REMOVE EXISTING SCREWS (2) AND REPLACE WITH FIND NUMBERS 8 AND 9.
16. VENDOR ITEM-SEE SPECIFICATION CONTROL DR
17.  HARDWARE SHOWN IS OPTIONAL.

QTY REQD	QTY REQD	QTY REQD	QTY REQD	QTY REQD	QTY REQD	QTY REQD	QTY REQD	FIND NO.	FSCM NO.	PART NUMBER OR IDENTIFYING NO.	NOMENCLATURE OR DESCRIPTION	SPEC/STD	SHEET NO.	NOTE
25	25	25	25	25	25	25	25	15						
25	25	25	25	25	25	25	25	14	81349	M39029/64-369	CONTACT, CRIMP, PIN	MIL-C-39029/64		
9	9	9	9	9	9	9	9	13	81349	M39029/63-368	CONTACT, CRIMP, SOCKET	MIL-C-39029/63		
1	1	1	1	1	1	1	1	12	81349	M24308/2-1	CONNECTOR, ELECTRICAL, RECEPTACLE	MIL-C-24308/2		
1	1	1	1	1	1	1	1	11	81349	M24308/4-3	CONNECTOR, ELECTRICAL, PLUG	MIL-C-24308/4		
								10						
2	2	2	2	2	2	2	2	9	96906	MS35338-136	WASHER, LOCK, NO. 6			
2	2	2	2	2	2	2	2	8	96906	MS51957-31	SCREW, PPH, 6-32 X 5/8L			
								7						
REF	REF	REF	REF	REF	REF	REF	REF	6	80063	A3092728	TEST PROCEDURE/DATA SHEET POWER AND SIGNAL CABLE TEST			
2	2	2	2	2	2	2	2	5	96906	MS15795-803	WASHER, FLAT, NO. 4			
2	2	2	2	2	2	2	2	4	96906	MS35338-135	WASHER, LOCK, NO. 4			
270	170	382	338	200	125	107	96	3	80063	A3093562-9	CABLE, ELECTRICAL, SPECIAL PURPOSE			13 , 16
1	1	1	1	1	1	1	1	2	80063	A3093549-3	BACKSHELL, EMI/RFI			16
1	1	1	1	1	1	1	1	1	80063	A3093549-1	BACKSHELL, EMI/RFI			16
-8	-7	-6	-5	-4	-3	-2	-1				PARTS LIST			

A3093597
Cable Assembly, Console
(Sheet 1 of 2)

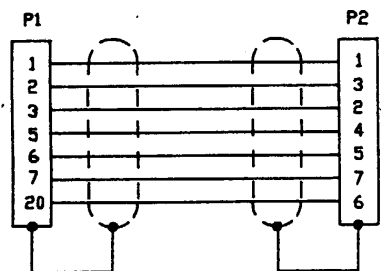

WIRING DIAGRAM

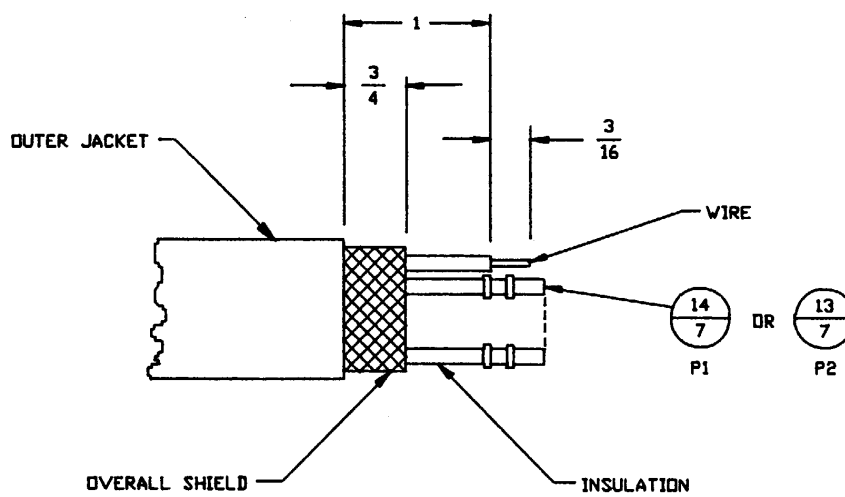
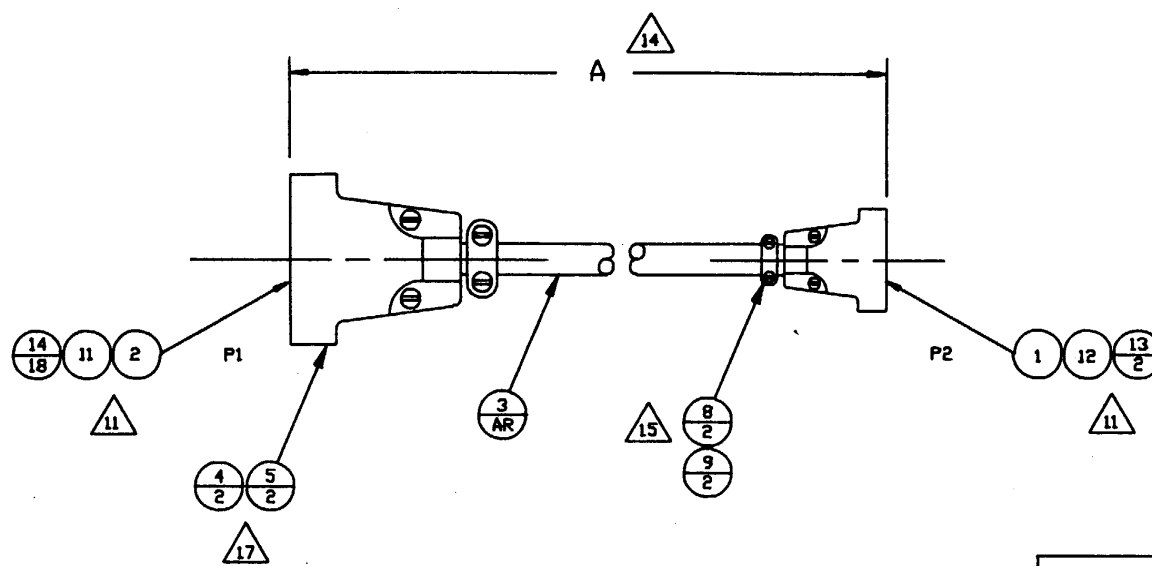

CABLE PREPARATION

SCALE : 2/1
BOTH ENDS

CHART A	
DASH NO.	DIMENSION A
1	96.00
2	107.00
3	125.00
4	200.00
5	338.00
6	382.00
7	170.00
8	270.00

A3093597
Cable Assembly, Console
(Sheet 2 of 2)

NOTES :

1. IDENTIFY PART PER MIL-STD-130, TAG.
2. WORKMANSHIP SHALL BE IN ACCORDANCE WITH MIL-STD-454, REQUIREMENT 9.
3. DIMENSIONAL DATA IS BASED ON AMERICAN NATIONAL STANDARD ANSI Y14.5-1973.
4. CRIMP INSERTION TOOL NO. M81969/1-02, REMOVAL TOOL NO. M81969/1-02, PER MIL-I-81969.
5. CRIMPING TOOL NO. M22520/2-01 WITH M22520/2-08 TURRET, PER MIL-C-22520.
6. EACH CONDUCTOR SHALL BE TESTED FOR CONTINUITY AND CORRECT CONNECTIONS BETWEEN ITS TERMINATIONS, USING A POTENTIAL OF NOT MORE THAN 10 VOLTS. CONTINUITY CHECKS SHALL BE MADE FROM CONNECTOR CONTACT TO CONNECTOR CONTACT USING A CONTINUITY TESTER. CONTINUITY POINTS SHALL BE OBTAINED FROM THE CABLE WIRING DIAGRAM. WHERE SHIELD IS BONDED TO CONNECTOR ON BOTH ENDS, THE SHIELD CONTINUITY SHALL BE CHECKED FROM CONNECTOR SHELL TO CONNECTOR SHELL.
7. INSULATION RESISTANCE SHALL BE IN ACCORDANCE WITH METHOD 302 OF MIL-STD-202, TEST CONDITION B. THE POTENTIAL SHALL BE APPLIED BETWEEN EACH CONDUCTOR AND THE REMAINING CONDUCTORS CONNECTED TOGETHER AND TO THE SHIELD, AND CONNECTOR. THE INSULATION RESISTANCE OF THE CABLE ASSEMBLY SHALL NOT BE LESS THAN 100 MEGOHMS. EXCEPT THE INSULATION RESISTANCE OF A SHIELDED CONDUCTOR SHALL NOT BE LESS THAN 30 MEGOHMS.
8. DIELECTRIC WITHSTANDING VOLTAGE. DIELECTRIC STRENGTH SHALL BE PERFORMED IN ACCORDANCE WITH METHOD 301 OF MIL-STD-202. A POTENTIAL OF 500 VOLTS DC SHALL BE APPLIED FOR 30 SECONDS MINIMUM. THE POTENTIAL SHALL BE APPLIED BETWEEN EACH CONDUCTOR AND THE REMAINING CONDUCTORS CONNECTED TOGETHER AND TO THE SHIELD AND CONNECTOR.
9. PARTIAL REFERENCE DESIGNATIONS ARE SHOWN. FOR COMPLETE REFERENCE DESIGNATION, PREFIX WITH UNIT NUMBER AND SUBASSEMBLY DESIGNATION.
10. FIND NO. 4 INCLUDES SLIDE LATCH, TWO LOCK WASHERS, TWO HEX NUTS AND TWO 2-56 SCREW. LOCK WASHERS ARE NOT USED.
11. DELETED
12. DELETED

13. DELETED
- △ ALL SHIELDS MUST TERMINATE INSIDE OF EMI BACKSHELL.
- △ ALL UNUSED POSITIONS IN CONNECTORS P1 & P2 ARE TO BE FILLED WITH CONTACTS.
16. DELETED
- △ QUANTITY SHOWN IS IN INCHES.
- △ TOLERANCE ON CABLE LENGTH SHALL BE +3,-0 INCHES.
- △ DIMENSIONS SHOWN ON CABLE PREPARATION ILLUSTRATION ARE FOR REFERENCE ONLY.
20. DELETED.
21. VENDOR ITEM, SEE SPECIFICATION CONTROL DRAWING.
22. FIND NO. 3 INCLUDES TWO LOCKING POSTS, TWO LOCK WASHERS AND TWO HEX NUTS PER PART NUMBER.
- △ REFER TO AMP INSTRUCTION SHEET IS6609 FOR CRIMPING FERRULE'S.

AR	15	81349	GRADE CVV	COMPOUND, LOCKING	MIL-S-22473		
REF	14	80063	A3092728	TEST PROCEDURE/DATA SHEET POWER AND SIGNAL CABLE TEST			
	15	13	81349	M39029/64-369	CONTACT, CRIMP, PIN	MIL-C-39029/64	
	15	12	81349	M39029/63-368	CONTACT, CRIMP, SOCKET	MIL-C-39029/63	
	1	11	81349	M24308/4-2	CONNECTOR, ELECTRICAL, PLUG	MIL-C-24308/4	
	1	10	81349	M24308/2-2	CONNECTOR, ELECTRICAL, RECEPTACLE	MIL-C-24308/2	
	4	9	80063	A3105761-5	WASHER, SADDLE		21
		8					
	2	7	80063	A3105775	INNER FERRULE		21
	2	6	80063	A3105774	OUTER FERRULE		21
	2	5	80063	A3105773	EMI/RFI BACKSHELL		21
	1	4	80063	A3105761-3	SIDE LATCH		10 , 21
	1	3	80063	A3105761-4	LOCKING POST		21 , 22
	10	2	80063	A3093562-9	CABLE, MULT-CONDUCTOR, AWG 22		17 , 21
		1					
QTY REQD	FIND NO.	FSCM NO.	PART NUMBER OR IDENTIFYING NO.	NOMENCLATURE OR DESCRIPTION	SPEC/STD	SHEET NO.	NOTE
PARTS LIST							

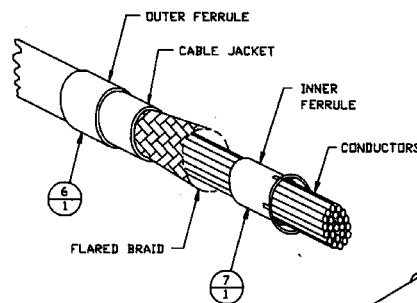
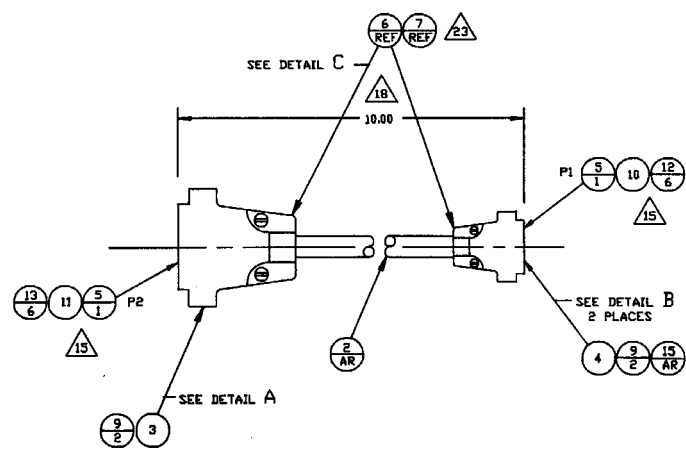

DETAIL C
SCALE: NONE
2 PLACES
P1, P2

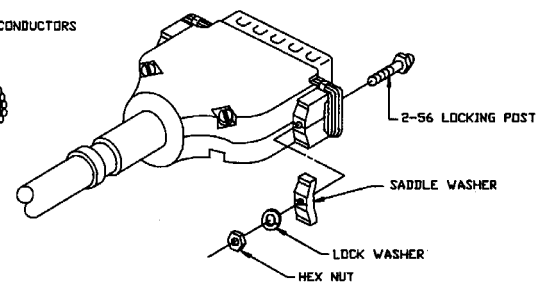

DETAIL A
SCALE: NONE
P2

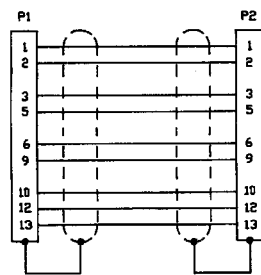

WIRING DIAGRAM

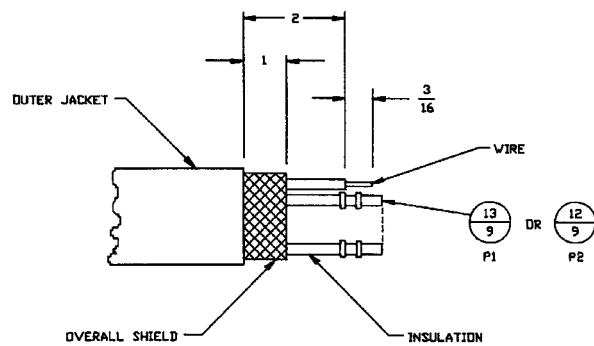



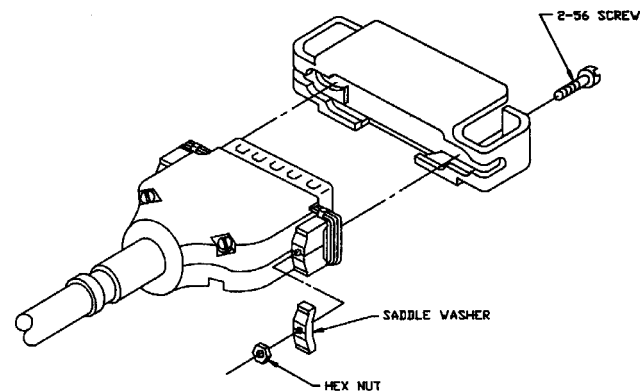

CABLE PREPARATION 14 19
SCALE: NONE



DETAIL B
SCALE: NONE
P1

Cable Assembly, AUI
(Sheet 2 of 2)

NOTES :

1. IDENTIFY PART PER MIL-STD-130, TAG.
2. WORKMANSHIP SHALL BE IN ACCORDANCE WITH MIL-STD-454, REQUIREMENT 9.
3. DIMENSIONAL DATA IS BASED ON AMERICAN NATIONAL STANDARD ANSI Y14.5-1973.
4. CRIMP INSERTION TOOL NO. M81969/1-02, REMOVAL TOOL NO. M81969/1-02, PER MIL-I-81969.
5. CRIMPING TOOL NO. M22520/2-01 WITH M22520/2-08 TURRET, PER MIL-C-22520.
6. EACH CONDUCTOR SHALL BE TESTED FOR CONTINUITY AND CORRECT CONNECTIONS BETWEEN ITS TERMINATIONS, USING A POTENTIAL OF NOT MORE THAN 10 VOLTS. CONTINUITY CHECKS SHALL BE MADE FROM CONNECTOR CONTACT TO CONNECTOR CONTACT USING A CONTINUITY TESTER. CONTINUITY POINTS SHALL BE OBTAINED FROM THE CABLE WIRING DIAGRAM. WHERE SHIELD IS BONDED TO CONNECTOR ON BOTH ENDS, THE SHIELD CONTINUITY SHALL BE CHECKED FROM CONNECTOR SHELL TO CONNECTOR SHELL.
7. INSULATION RESISTANCE SHALL BE IN ACCORDANCE WITH METHOD 302 OF MIL-STD-202, TEST CONDITION B. THE POTENTIAL SHALL BE APPLIED BETWEEN EACH CONDUCTOR AND THE REMAINING CONDUCTORS CONNECTED TOGETHER AND TO THE SHIELD, AND CONNECTOR. THE INSULATION RESISTANCE OF THE CABLE ASSEMBLY SHALL NOT BE LESS THAN 100 MEGOHMS. EXCEPT THE INSULATION RESISTANCE OF A SHIELDED CONDUCTOR SHALL NOT BE LESS THAN 30 MEGOHMS.
8. DIELECTRIC WITHSTANDING VOLTAGE. DIELECTRIC STRENGTH SHALL BE PERFORMED IN ACCORDANCE WITH METHOD 301 OF MIL-STD-202. A POTENTIAL OF 500 VOLTS DC SHALL BE APPLIED FOR 30 SECONDS MINIMUM. THE POTENTIAL SHALL BE APPLIED BETWEEN EACH CONDUCTOR AND THE REMAINING CONDUCTORS CONNECTED TOGETHER AND TO THE SHIELD AND CONNECTOR.
9. PARTIAL REFERENCE DESIGNATIONS ARE SHOWN FOR COMPLETE REFERENCE DESIGNATION, PREFIX WITH UNIT NUMBER AND SUBASSEMBLY DESIGNATION.
10. SOLDERING SHALL BE IN ACCORDANCE WITH MIL-STD-454, REQUIREMENT 5.
 ALL UNUSED POSITIONS IN CONNECTORS P1 & P2 ARE TO BE FILLED WITH CONTACTS.
12. COMPLETE PART NUMBER FOR THIS ASSEMBLY SHALL INCLUDE APPLICABLE DASH NUMBER INDICATED IN QUANTITY REQUIRED COLUMN.
13. QUANTITY SHOWN IS IN INCHES.
 TOLERANCE ON CABLE LENGTH SHALL BE +2,-1 INCHES.
 DIMENSIONS SHOWN IN CABLE PREPARATION ILLUSTRATION ARE FOR REFERENCE ONLY.
16. VENDOR ITEM-SEE SPECIFICATION CONTROL DRAWING.
 HARDWARE SHOWN IS OPTIONAL.

25	25	25	25	25	25	14	81349	M39029/64-369	CONTACT, CRIMP, PIN	MIL-C-39029/64		
25	25	25	25	25	25	13	81349	M39029/63-368	CONTACT, CRIMP, SOCKET	MIL-C-39029/63		
1	1	1	1	1	1	12	81349	M24308/4-3	CONNECTOR, ELECTRICAL, PLUG	MIL-C-24308/4		
1	1	1	1	1	1	11	81349	M24308/2-3	CONNECTOR, ELECTRICAL, RECEPTACLE	MIL-C-24308/2		
						10						
2	2	2	2	2	2	9	96906	MS15795-803	WASHER, FLAT, NO. 4			
2	2	2	2	2	2	8	96906	MS35338-135	WASHER, LOCK, NO. 4			
						7						
						6						
REF	REF	REF	REF	REF	REF	5	80063	A3092728	TEST PROCEDURE/DATA SHEET POWER AND SIGNAL CABLE TEST			
						4						
124	118	112	106	100	94	3	80063	A3093562-9	CABLE, ELECTRICAL, SPECIAL PURPOSE			13 , 16
1	1	1	1	1	1	2	80063	A3093549-3	BACKSHELL, EMI/RFI			16
1	1	1	1	1	1	1	80063	A3093548-3	BACKSHELL, EMI/RFI			16
QTY REQD	QTY REQD	QTY REQD	QTY REQD	QTY REQD	QTY REQD	FIND NO.	FSCM NO.	PART NUMBER OR IDENTIFYING NO.	NOMENCLATURE OR DESCRIPTION	SPEC/STD	SHEET NO.	NOTE
PARTS LIST												

PARTS LIST
 Cable Assembly, CP/Patch
 (Sheet 1 of 2)

A3093599

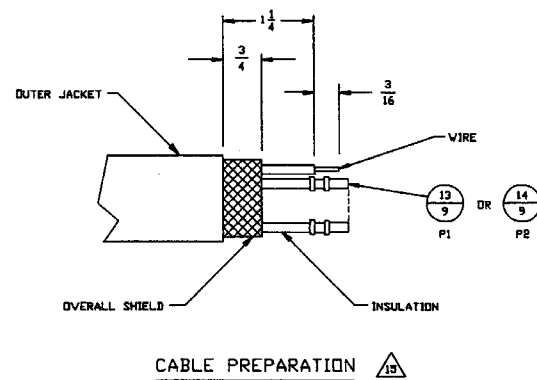
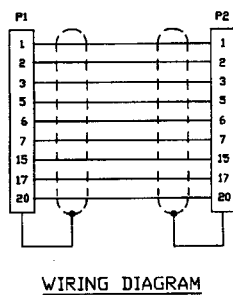
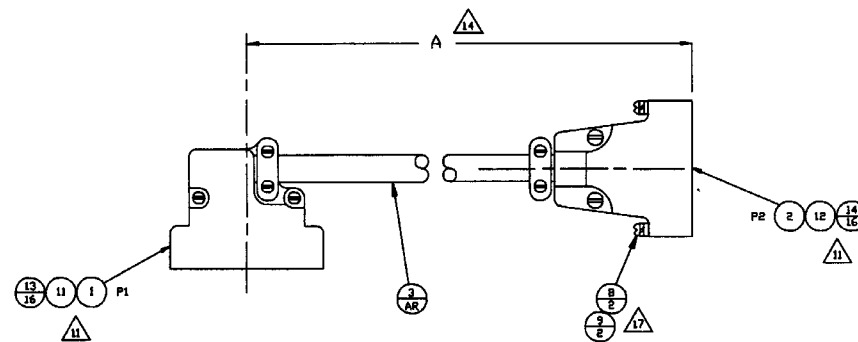

CABLE PREPARATION Δ





SCALE : 2/1
BOTH ENDS

CHART A	
DASH NO.	DIMENSION A
1	94.00
2	100.00
3	106.00
4	112.00
5	118.00
6	124.00

Cable Assembly, CP/Patch
(Sheet 2 of 2)

NOTES :

1. IDENTIFY PART PER MIL-STD-130, TAG.
2. WORKMANSHIP SHALL BE IN ACCORDANCE WITH MIL-STD-454, REQUIREMENT 9.
3. DIMENSIONAL DATA IS BASED ON AMERICAN NATIONAL STANDARD ANSI Y14.5-1973.
4. CRIMP INSERTION TOOL NO. M81969/1-02, REMOVAL TOOL NO. M81969/1-02, PER MIL-I-81969.
5. CRIMPING TOOL NO. M22520/2-01 WITH M22520/2-08 TURRET, PER MIL-C-22520.
6. EACH CONDUCTOR SHALL BE TESTED FOR CONTINUITY AND CORRECT CONNECTIONS BETWEEN ITS TERMINATIONS, USING A POTENTIAL OF NOT MORE THAN 10 VOLTS. CONTINUITY CHECKS SHALL BE MADE FROM CONNECTOR CONTACT TO CONNECTOR CONTACT USING A CONTINUITY TESTER. CONTINUITY POINTS SHALL BE OBTAINED FROM THE CABLE WIRING DIAGRAM. WHERE SHIELD IS BONDED TO CONNECTOR ON BOTH ENDS, THE SHIELD CONTINUITY SHALL BE CHECKED FROM CONNECTOR SHELL TO CONNECTOR SHELL.
7. INSULATION RESISTANCE SHALL BE IN ACCORDANCE WITH METHOD 302 OF MIL-STD-202, TEST CONDITION B. THE POTENTIAL SHALL BE APPLIED BETWEEN EACH CONDUCTOR AND THE REMAINING CONDUCTORS CONNECTED TOGETHER AND TO THE SHIELD, AND CONNECTOR. THE INSULATION RESISTANCE OF THE CABLE ASSEMBLY SHALL NOT BE LESS THAN 100 MEGOHMS, EXCEPT THE INSULATION RESISTANCE OF A SHIELDED CONDUCTOR SHALL NOT BE LESS THAN 30 MEGOHMS.
8. DIELECTRIC WITHSTANDING VOLTAGE. DIELECTRIC STRENGTH SHALL BE PERFORMED IN ACCORDANCE WITH METHOD 301 OF MIL-STD-202. A POTENTIAL OF 500 VOLTS DC SHALL BE APPLIED FOR 30 SECONDS MINIMUM. THE POTENTIAL SHALL BE APPLIED BETWEEN EACH CONDUCTOR AND THE REMAINING CONDUCTORS CONNECTED TOGETHER AND TO THE SHIELD AND CONNECTOR.
9. PARTIAL REFERENCE DESIGNATIONS ARE SHOWN. FOR COMPLETE REFERENCE DESIGNATION, PREFIX WITH UNIT NUMBER AND SUBASSEMBLY DESIGNATION.
10. COMPLETE PART NUMBER FOR THIS ASSEMBLY SHALL INCLUDE APPROPRIATE DASH NUMBER INDICATED IN QUANTITY REQUIRED COLUMN.

-  ALL UNUSED POSITIONS IN CONNECTORS P1 & P2 ARE TO BE FILLED WITH CONTACTS.
- 12. QUANTITY SHOWN IS IN INCHES.
-  TOLERANCE ON CABLE LENGTH SHALL BE +2,-1 INCHES.
- 14. VENDOR ITEM - SEE SPECIFICATION CONTROL DRAWING.
-  DIMENSIONS SHOWN ON CABLE PREPARATION ILLUSTRATION ARE FOR REFERENCE ONLY.
-  HARDWARE SHOWN IS OPTIONAL.

25	25	25	13	81349	M39029/64-369	CONTACT, CRIMP, PIN	MIL-C-39029/64		
25	25	25	12	81349	M39029/63-368	CONTACT, CRIMP, SOCKET	MIL-C-39029/63		
1	1	1	11	81349	M24308/4-3	CONNECTOR, ELECTRICAL, PLUG	MIL-C-24308/4		
1	1	1	10	81349	M24308/2-3	CONNECTOR, ELECTRICAL, RECEPTACLE	MIL-C-24308/2		
4	4	4	9	96906	MS15795-803	WASHER, FLAT, NO.4			
4	4	4	8	96906	MS35338-135	WASHER, LOCK, NO. 4			
			7						
			6						
REF	REF	REF	5	80063	A3092728	TEST PROCEDURE/DATA SHEET POWER AND SIGNAL CABLE TEST			
			4						
			3						
469	416	85	2	80063	A3093562-9	CABLE, ELECTRICAL, SPECIAL PURPOSE		12 , 14	
2	2	2	1	80063	A3093549-3	BACKSHELL, EMI/RFI		14	
QTY REQD	QTY REQD	QTY REQD	FIND NO.	FSCM NO.	PART NUMBER OR IDENTIFYING NO.	NOMENCLATURE OR DESCRIPTION	SPEC/STD	SHEET NO.	NOTE
PARTS LIST									

Cable Assembly, WS/Patch
(Sheet 1 of 2)

A3093600

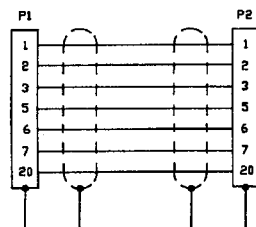
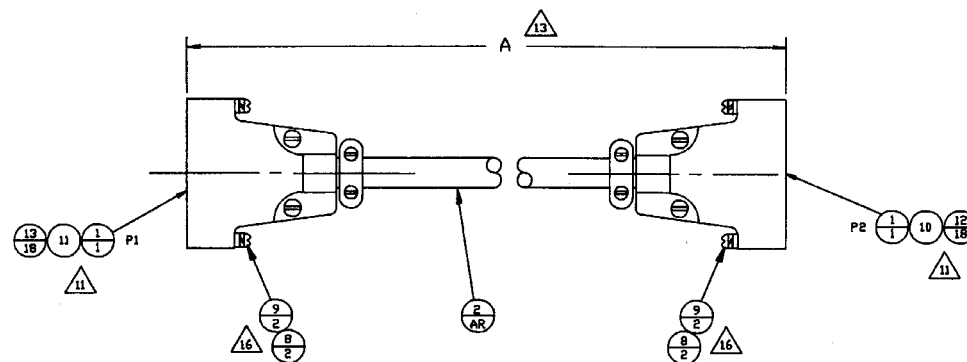

WIRING DIAGRAM

CHART	
DASH NO.	DIMENSION A
1	85.00
2	416.00
3	469.00

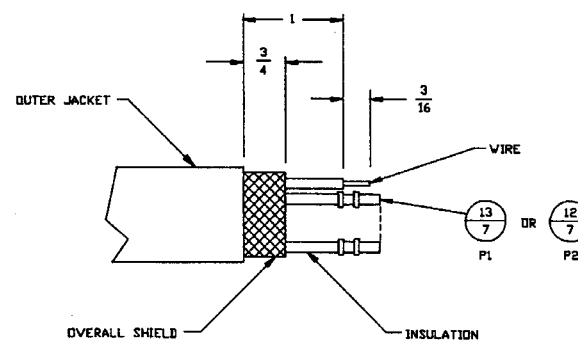

CABLE PREPARATION

SCALE : 2/1
BOTH ENDS

Cable Assembly, WS/Patch
(Sheet 2 of 2)

CHART		
DASH NO.	DIMENSION A	DIMENSION B
1	12.00	9.5 MINIMUM
2	91.00	9.5 MINIMUM
3	100.00	5.0 MINIMUM
4	210.00	5.0 MINIMUM

NOTES :



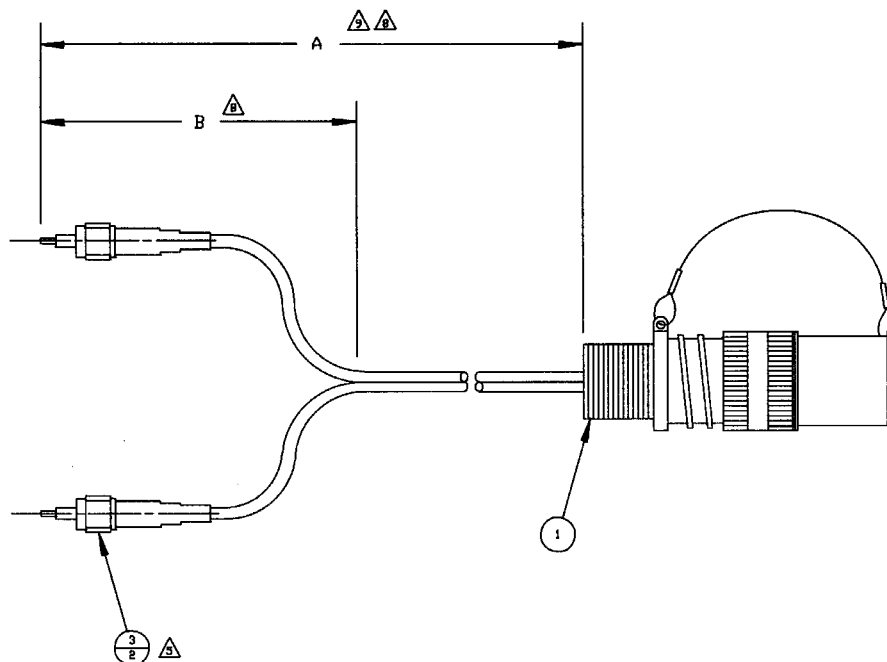

1. IDENTIFY PART PER MIL-STD-130, TAG.
2. WORKMANSHIP SHALL BE IN ACCORDANCE WITH MIL-STD-454, REQUIREMENT 9.
3. DIMENSIONAL DATA IS BASED ON AMERICAN NATIONAL STANDARD ANSI Y14.5-1973.
4. PARTIAL REFERENCE DESIGNATION ARE SHOWN. FOR COMPLETE REFERENCE DESIGNATION, PREFIX WITH UNIT NUMBER AND SUBASSEMBLY DESIGNATION.
- ⚠ TERMINATE FIBER OPTIC CONNECTORS, ITEM 2, PER MFG (AMP, FSCM 00779) INSTRUCTION SHEET A3092929. REQUIRED TOOLS ARE DEFINED BY INSTRUCTION SHEET. TRANSMISSION LOSS SHALL NOT BE GREATER THAN 0.7dB AT EITHER TERMINATION.
6. VENDOR ITEM, SEE SPECIFICATION CONTROL DRAWING.
7. DELETED
- ⚠ LENGTH SHOWN IS IN INCHES.
- ⚠ TOLERANCE ON CABLE LENGTH SHALL BE +4,-2 INCHES. THE BREAKOUTS DO NOT HAVE TO BE OF EQUAL LENGTH.
10. COMPLETE PART NUMBER FOR THIS ASSEMBLY SHALL INCLUDE APPLICABLE DASH NUMBER INDICATED IN QUANTITY REQUIRED COLUMN.



2	2	2	2	3	80063	A3093557-1	CONNECTOR KIT, FSMA II			6
				2						
1	1	1	1	1	80063	A3105810	CONNECTOR ASSEMBLY, FIBER OPTIC, DUAL FIBER, BULKHEAD			6
QTY REQD	QTY REQD	QTY REQD	QTY REQD	FIND NO.	FSCM NO.	PART NUMBER OR IDENTIFYING NO.	NOMENCLATURE OR DESCRIPTION	SPEC/STD	SHEET NO.	NOTE
-4	-3	-2	-1	PARTS LIST						

Cable Assembly, Fiber Optic

NOTES :

1. IDENTIFY PART PER MIL-STD-130, TAG.
2. WORKMANSHIP SHALL BE IN ACCORDANCE WITH MIL-STD-454, REQUIREMENT 9.
3. DIMENSIONAL DATA IS BASED ON AMERICAN NATIONAL STANDARD ANSI Y14.5-1973.
4. CRIMP INSERTION TOOL NO. M81969/1-02, REMOVAL TOOL NO. M81969/1-02, PER MIL-1-81969.
5. CRIMPING TOOL NO. M22520/2-01 WITH M22520/2-08 TURRET, PER MIL-C-22520.
6. EACH CONDUCTOR SHALL BE TESTED FOR CONTINUITY AND CORRECT CONNECTIONS BETWEEN ITS TERMINATIONS, USING A POTENTIAL OF NOT MORE THAN 10 VOLTS. CONTINUITY CHECKS SHALL BE MADE FROM CONNECTOR CONTACT TO CONNECTOR CONTACT USING A CONTINUITY TESTER. CONTINUITY POINTS SHALL BE OBTAINED FROM THE CABLE WIRING DIAGRAM. WHERE SHIELD IS BONDED TO CONNECTOR ON BOTH ENDS, THE SHIELD CONTINUITY SHALL BE CHECKED FROM CONNECTOR SHELL TO CONNECTOR SHELL.
7. INSULATION RESISTANCE SHALL BE IN ACCORDANCE WITH METHOD 302 OF MIL-STD-202, TEST CONDITION B. THE POTENTIAL SHALL BE APPLIED BETWEEN EACH CONDUCTOR AND THE REMAINING CONDUCTORS CONNECTED TOGETHER AND TO THE SHIELD, AND CONNECTOR. THE INSULATION RESISTANCE OF THE CABLE ASSEMBLY SHALL NOT BE LESS THAN 100 MEGOHMS. EXCEPT THE INSULATION RESISTANCE OF A SHIELDED CONDUCTOR SHALL NOT BE LESS THAN 30 MEGOHMS.
8. DIELECTRIC WITHSTANDING VOLTAGE. DIELECTRIC STRENGTH SHALL BE PERFORMED IN ACCORDANCE WITH METHOD 301 OF MIL-STD-202. A POTENTIAL OF 500 VOLTS DC SHALL BE APPLIED FOR 30 SECONDS MINIMUM. THE POTENTIAL SHALL BE APPLIED BETWEEN EACH CONDUCTOR AND THE REMAINING CONDUCTORS CONNECTED TOGETHER AND TO THE SHIELD AND CONNECTOR.
9. PARTIAL REFERENCE DESIGNATIONS ARE SHOWN. FOR COMPLETE REFERENCE DESIGNATION, PREFIX WITH UNIT NUMBER AND SUBASSEMBLY DESIGNATION.
10. SOLDERING SHALL BE IN ACCORDANCE WITH MIL-STD-454, REQUIREMENT 5.
 ALL UNUSED POSITIONS IN CONNECTORS P1 & P2 ARE TO BE FILLED WITH CONTACTS.
12. COMPLETE PART NUMBER FOR THIS ASSEMBLY SHALL INCLUDE APPLICABLE DASH NUMBER INDICATED IN QUANTITY REQUIRED COLUMN.
13. QUANTITY SHOWN IS IN INCHES.
 TOLERANCE ON CABLE LENGTH SHALL BE +2,-1 INCHES.
 DIMENSIONS SHOWN IN CABLE PREPARATION ILLUSTRATION ARE FOR REFERENCE ONLY.
16. VENDOR ITEM-SEE SPECIFICATION CONTROL DRAWING.
 HARDWARE SHOWN IS OPTIONAL.

25	25	25	25	14	81349	M39029/64-369	CONTACT, CRIMP, PIN	MIL-C-39029/64		
25	25	25	25	13	81349	A39029/63-368	CONTACT, CRIMP, SOCKET	MIL-C-39029/63		
1	1	1	1	12	81349	M24308/4-3	CONNECTOR, ELECTRICAL, PLUG	MIL-C-24308/4		
1	1	1	1	11	81349	M24308/2-3	CONNECTOR, ELECTRICAL, RECEPTACLE	MIL-C-24308/2		
				10						
2	2	2	2	9	96906	MS15795-803	WASHER, FLAT, NO. 4			
2	2	2	2	8	96906	MS35338-135	WASHER, LOCK, NO. 4			
				7						
				6						
REF	REF	REF	REF	5	80063	A3092728	TEST PROCEDURE/DATA SHEET POWER AND SIGNAL CABLE TEST			
				4						
1	1	1	1	3	80063	A3093576-8	BACKSHELL, EMI/RFI			16
176	160	144	128	2	80063	A3093562-9	CABLE, ELECTRICAL, SPECIAL PURPOSE			13, 16
1	1	1	1	1	80063	A3093549-3	BACKSHELL, EMI/RFI			16
QTY REQD	QTY REQD	QTY REQD	QTY REQD	FIND NO.	FSCM NO.	PART NUMBER OR IDENTIFYING NO.	NOMENCLATURE OR DESCRIPTION	SPEC/STD	SHEET NO.	NOTE
-4	-3	-2	-1				PARTS LIST			

Cable Assembly, Patch/DSDI
(Sheet 1 of 2)

A3093602

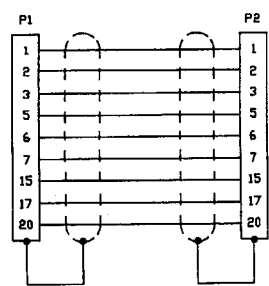
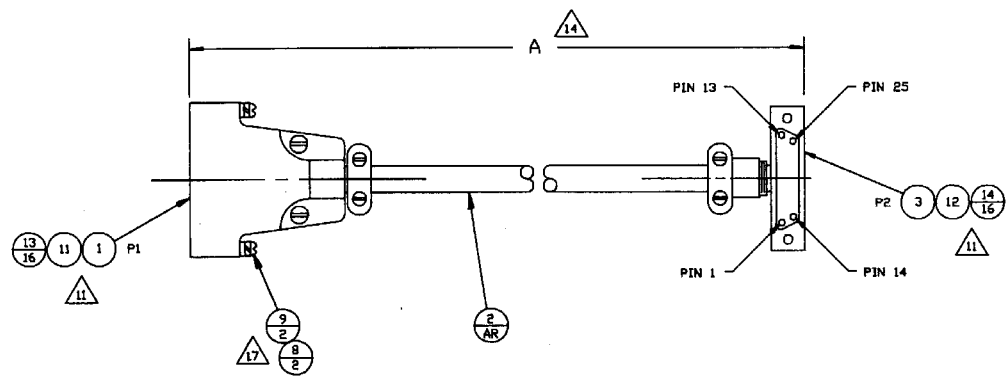

WIRING DIAGRAM

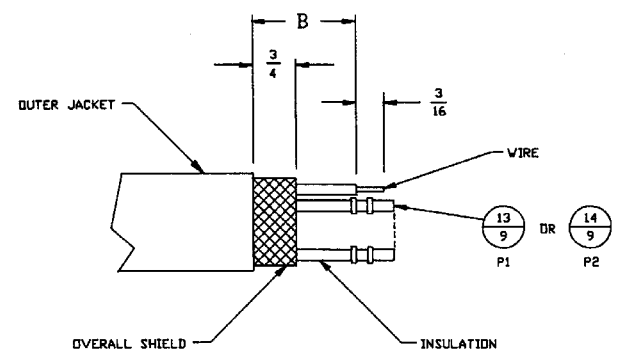

CABLE PREPARATION $\triangle 15$

SCALE : 2/1
BOTH ENDS



CHART A	
DASH NO.	DIMENSION A
1	128.00
2	144.00
3	160.00
4	176.00

CHART B	
END TYPE	DIMENSION B
P1	1.25 REF
P2	2.00 REF

Cable Assembly, Patch/DSDI
(Sheet 2 of 2)

NOTES :

1. IDENTIFY PART PER MIL-STD-130, TAG.
2. WORKMANSHIP SHALL BE IN ACCORDANCE WITH MIL-STD-454, REQUIREMENT 9.
3. DIMENSIONAL DATA IS BASED ON AMERICAN NATIONAL STANDARD ANSI Y14.5-1973.
4. CRIMP INSERTION TOOL NO. 81969/17-03, REMOVAL TOOL NO. M81969/19-07, PER MIL-I-81969.
5. CRIMPING TOOL NO. M22520/2-01 WITH M22520/2-07 TURRET, PER MIL-C-22520.
6. EACH CONDUCTOR SHALL BE TESTED FOR CONTINUITY AND CORRECT CONNECTIONS BETWEEN ITS TERMINATIONS, USING A POTENTIAL OF NOT MORE THAN 10 VOLTS. CONTINUITY CHECKS SHALL BE MADE FROM CONNECTOR CONTACT TO CONNECTOR CONTACT USING A CONTINUITY TESTER. CONTINUITY POINTS SHALL BE OBTAINED FROM THE CABLE WIRING DIAGRAM. WHERE SHIELD IS BONDED TO CONNECTOR ON BOTH ENDS, THE SHIELD CONTINUITY SHALL BE CHECKED FROM CONNECTOR SHELL TO CONNECTOR SHELL.
7. INSULATION RESISTANCE SHALL BE IN ACCORDANCE WITH METHOD 302 OF MIL-STD-202, TEST CONDITION B. THE POTENTIAL SHALL BE APPLIED BETWEEN EACH CONDUCTOR AND THE REMAINING CONDUCTORS CONNECTED TOGETHER AND TO THE SHIELD, AND CONNECTOR. THE INSULATION RESISTANCE OF THE CABLE ASSEMBLY SHALL NOT BE LESS THAN 100 MEGOHMS. EXCEPT THE INSULATION RESISTANCE OF A SHIELDED CONDUCTOR SHALL NOT BE LESS THAN 30 MEGOHMS.
8. DIELECTRIC WITHSTAND VOLTAGE. DIELECTRIC STRENGTH SHALL BE PERFORMED IN ACCORDANCE WITH METHOD 301 OF MIL-STD-202. A POTENTIAL OF 500 VOLTS DC SHALL BE APPLIED FOR 30 SECONDS MINIMUM. THE POTENTIAL SHALL BE APPLIED BETWEEN EACH CONDUCTOR AND THE REMAINING CONDUCTORS CONNECTED TOGETHER AND TO THE SHIELD AND CONNECTOR.
9. PARTIAL REFERENCE DESIGNATION ARE SHOWN. FOR COMPLETE REFERENCE DESIGNATION, PREFIX WITH UNIT NUMBER AND SUBASSEMBLY DESIGNATION.
10. SOLDERING SHALL BE IN ACCORDANCE WITH MIL-STD-454, REQUIREMENT 5.

-  ALL UNUSED POSITIONS IN CONNECTOR P1 & P2 ARE TO BE FILLED WITH CONTACTS.
- 12. DELETED.
- 13. QUANTITY SHOWN IS IN INCHES.
-  TOLERANCE ON CABLE LENGTH SHALL BE +2,-1 INCHES.
- 15. VENDOR ITEM - SEE SPECIFICATION CONTROL DRAWING.

110	11	81349	M30929/56-348	CONTACT, CRIMP, SOCKET	MIL-C-39029/56		
2	10	96906	MS27467T17B35S	CONNECTOR, ELECTRICAL, PLUG			
	9						
	8						
	7						
	6						
REF	5	80063	A3092728	TEST PROCEDURE/DATA SHEET POWER AND SIGNAL CABLE TEST			
	4						
	3						
2	2	80063	A3093577-2	BACKSHELL, EMI/RFI			15
24	1	80063	A3093562-26	CABLE, ELECTRICAL, SPECIAL PURPOSE			13, 15
QTY REQD	FIND NO.	FSCM NO.	PART NUMBER OR IDENTIFYING NO.	NOMENCLATURE OR DESCRIPTION	SPEC/STD	SHEET NO.	NOTE
PARTS LIST							

Cable Assembly, Workstation/Patch
(Sheet 1 of 2)

A3093604

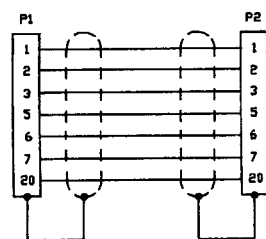
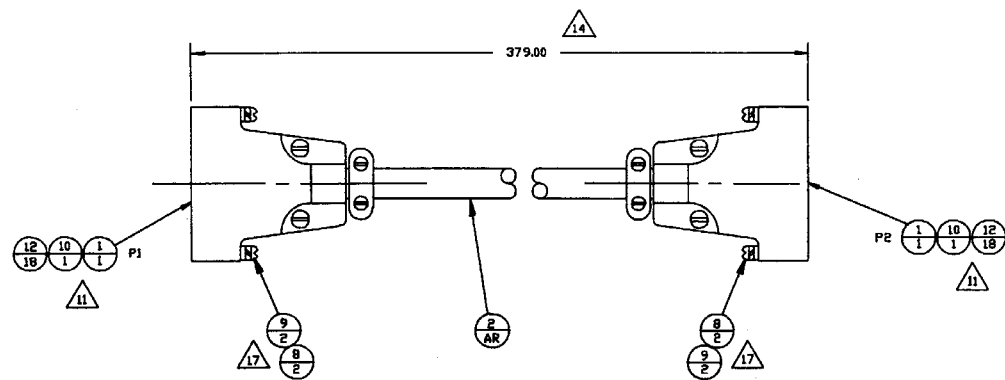

WIRING DIAGRAM

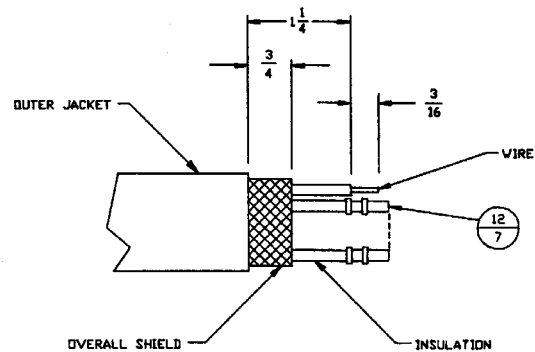

CABLE PREPARATION

SCALE : 2/1
BOTH ENDS

Cable Assembly, Workstation/Patch
(Sheet 2 of 2)

NOTES :

1. IDENTIFY PART PER MIL-STD-130, TAG.
2. WORKMANSHIP SHALL BE IN ACCORDANCE WITH MIL-STD-454, REQUIREMENT 9.
3. DIMENSIONAL DATA IS BASED ON AMERICAN NATIONAL STANDARD ANSI Y14.5-1973.
4. CRIMP INSERTION TOOL NO. 81969/17-03, REMOVAL TOOL NO. M81969/19-07, PER MIL-I-81969.
5. CRIMPING TOOL NO. M22520/2-01 WITH M22520/2-07 TURRET, PER MIL-C-22520.
6. EACH CONDUCTOR SHALL BE TESTED FOR CONTINUITY AND CORRECT CONNECTIONS BETWEEN ITS TERMINATIONS, USING A POTENTIAL OF NOT MORE THAN 10 VOLTS. CONTINUITY CHECKS SHALL BE MADE FROM CONNECTOR CONTACT TO CONNECTOR CONTACT USING A CONTINUITY TESTER. CONTINUITY POINTS SHALL BE OBTAINED FROM THE CABLE WIRING DIAGRAM. WHERE SHIELD IS BONDED TO CONNECTOR ON BOTH ENDS, THE SHIELD CONTINUITY SHALL BE CHECKED FROM CONNECTOR SHELL TO CONNECTOR SHELL.
7. INSULATION RESISTANCE SHALL BE IN ACCORDANCE WITH METHOD 302 OF MIL-STD-202, TEST CONDITION B. THE POTENTIAL SHALL BE APPLIED BETWEEN EACH CONDUCTOR AND THE REMAINING CONDUCTORS CONNECTED TOGETHER AND TO THE SHIELD, AND CONNECTOR. THE INSULATION RESISTANCE OF THE CABLE ASSEMBLY SHALL NOT BE LESS THAN 100 MEGOHMS. EXCEPT THE INSULATION RESISTANCE OF A SHIELDED CONDUCTOR SHALL NOT BE LESS THAN 30 MEGOHMS.
8. DIELECTRIC WITHSTAND VOLTAGE. DIELECTRIC STRENGTH SHALL BE PERFORMED IN ACCORDANCE WITH METHOD 301 OF MIL-STD-202. A POTENTIAL OF 500 VOLTS DC SHALL BE APPLIED FOR 30 SECONDS MINIMUM. THE POTENTIAL SHALL BE APPLIED BETWEEN EACH CONDUCTOR AND THE REMAINING CONDUCTORS CONNECTED TOGETHER AND TO THE SHIELD AND CONNECTOR.
9. PARTIAL REFERENCE DESIGNATION ARE SHOWN. FOR COMPLETE REFERENCE DESIGNATION, PREFIX WITH UNIT NUMBER AND SUBASSEMBLY DESIGNATION.
10. SOLDERING SHALL BE IN ACCORDANCE WITH MIL-STD-454, REQUIREMENT 5.

- ⚠ ALL UNUSED POSITIONS IN CONNECTOR P1 & P2 ARE TO BE FILLED WITH CONTACTS.
- 12. DELETED.
- 13. QUANTITY SHOWN IS IN INCHES.
- ⚠ TOLERANCE ON CABLE LENGTH SHALL BE +2,-1 INCHES.
- 15. VENDOR ITEM - SEE SPECIFICATION CONTROL DRAWING.

110	11	81349	M30929/56-348	CONTACT, CRIMP, SOCKET	MIL-C-39029/56		
2	10	96906	MS27467T17B35S	CONNECTOR, ELECTRICAL, PLUG			
	9						
	8						
	7						
	6						
REF	5	80063	A3092728	TEST PROCEDURE/DATA SHEET POWER AND SIGNAL CABLE TEST			
	4						
	3						
2	2	80063	A3093577-2	BACKSHELL, EMI/RFI			15
24	1	80063	A3093562-26	CABLE, ELECTRICAL, SPECIAL PURPOSE			13 , 15
QTY REQD	FIND NO.	FSCM NO.	PART NUMBER OR IDENTIFYING NO.	NOMENCLATURE OR DESCRIPTION	SPEC/STD	SHEET NO.	NOTE
PARTS LIST							

Cable Assembly, DSDUKY68
(Sheet 1 of 2)

A3093605

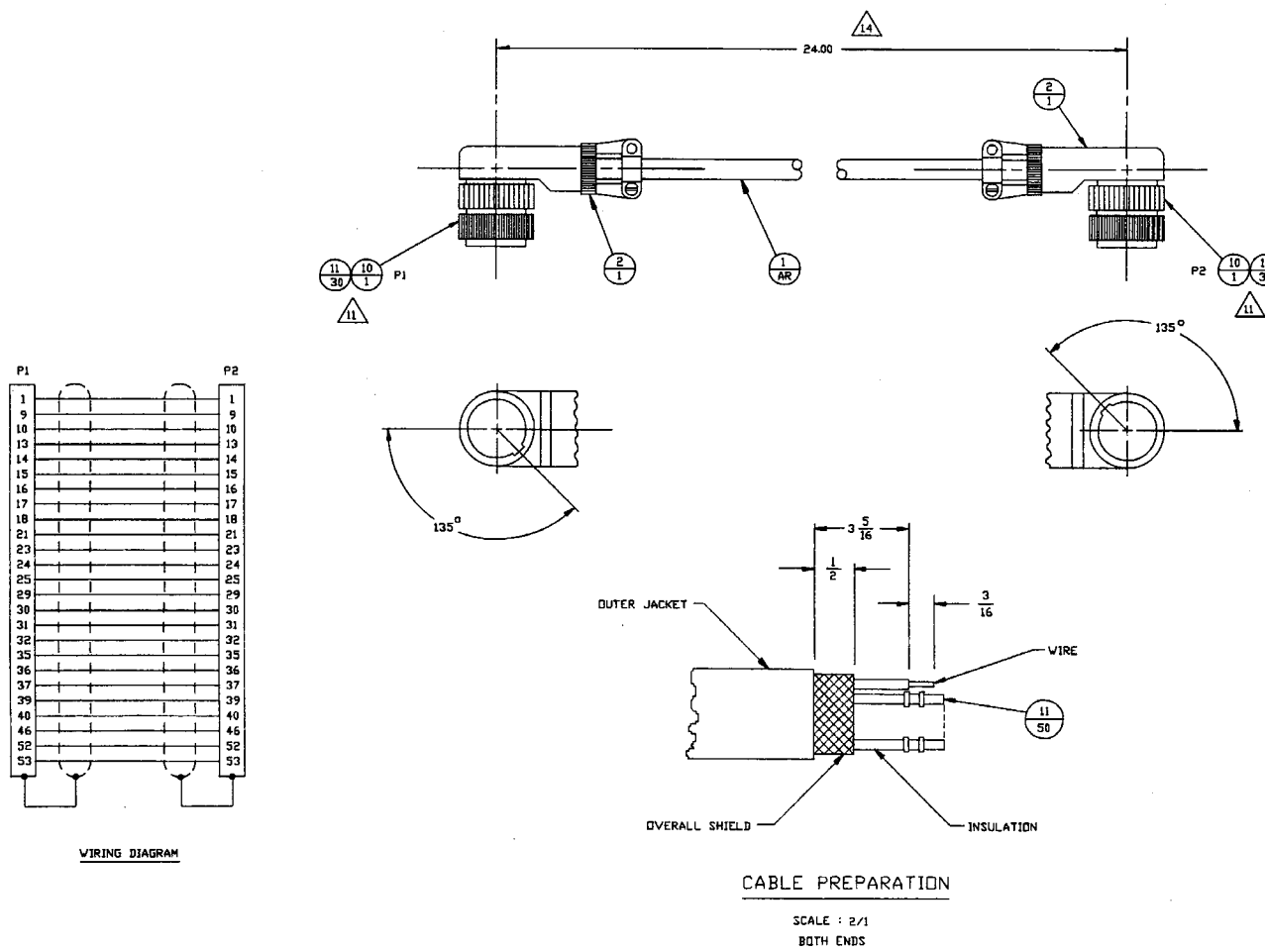





Cable Assembly, DSDIIKY68
(Sheet 2 of 2)

NOTES :

1. IDENTIFY PART PER MIL-STD-130, TAG.
2. WORKMANSHIP SHALL BE IN ACCORDANCE WITH MIL-STD-454, REQUIREMENT 9.
3. DIMENSIONAL DATA IS BASED ON AMERICAN NATIONAL STANDARD ANSI Y14.5-1973.
4. CRIMP INSERTION TOOL NO. FOR P1 M81969/17-03, REMOVAL TOOL NO. M81969/19-07, PER MIL-I-81969, FOR P2 INSERTION AND REMOVAL TOOL NO. M81969/14-01, PER MIL-I-81969.
5. CRIMPING TOOL NO. FOR P1 M22520/1-01 WITH M22520/1-02 TURRET, PER MIL-C-22520, FOR P2 CRIMPING TOOL NO. M22520/2-01, TURRET NO. M22520/2-07, PER MIL-C-22520.
6. EACH CONDUCTOR SHALL BE TESTED FOR CONTINUITY AND CORRECT CONNECTIONS BETWEEN ITS TERMINATIONS, USING A POTENTIAL OF NOT MORE THAN 10 VOLTS. CONTINUITY CHECKS SHALL BE MADE FROM CONNECTOR CONTACT TO CONNECTOR CONTACT USING A CONTINUITY TESTER. CONTINUITY POINTS SHALL BE OBTAINED FROM THE CABLE WIRING DIAGRAM. WHERE SHIELD IS BONDED TO CONNECTOR ON BOTH ENDS, THE SHIELD CONTINUITY SHALL BE CHECKED FROM CONNECTOR SHELL TO CONNECTOR SHELL.

7. INSULATION RESISTANCE SHALL BE IN ACCORDANCE WITH METHOD 302 OF MIL-STD-202, TEST CONDITION B. THE POTENTIAL SHALL BE APPLIED BETWEEN EACH CONDUCTOR AND THE REMAINING CONDUCTORS CONNECTED TOGETHER AND TO THE SHIELD, AND CONNECTOR. THE INSULATION RESISTANCE OF THE CABLE ASSEMBLY SHALL NOT BE LESS THAN 100 MEGOHMS, EXCEPT THE INSULATION RESISTANCE OF A SHIELDED CONDUCTOR SHALL NOT BE LESS THAN 30 MEGOHMS.
 8. DIELECTRIC WITHSTANDING VOLTAGE. DIELECTRIC STRENGTH SHALL BE PERFORMED IN ACCORDANCE WITH METHOD 301 OF MIL-STD-202. A POTENTIAL OF 500 VOLTS DC SHALL BE APPLIED FOR 30 SECONDS MINIMUM. THE POTENTIAL SHALL BE APPLIED BETWEEN EACH CONDUCTOR AND THE REMAINING CONDUCTORS CONNECTED TOGETHER AND TO THE SHIELD AND CONNECTOR.
 9. PARTIAL REFERENCE DESIGNATIONS ARE SHOWN. FOR COMPLETE REFERENCE DESIGNATION, PREFIX WITH UNIT NUMBER AND SUBASSEMBLY DESIGNATION.
 10. SOLDERING SHALL BE IN ACCORDANCE WITH MIL-STD-454, REQUIREMENT 5.
-  DIMENSIONS B (RANGE 1/4 TO 1/2) AND DIMENSION C (RANGE 1/2 TO 3/4) CAN INCREASE OR DECREASE PROPORTIONALLY TO ALLOW SOLDER FERRULE PLACEMENT TO BE VARIED.

-  INSTALL FERRULES ON SHIELDED TWISTED PAIRS AND SINGLE SHIELDED WIRE STARTING AT 1/2 INCH FROM END OF CABLE AND 3/4 INCH SO FERRULES WILL NOT TERMINATE AT THE SAME LOCATION.
-  WHEN BACKSHELL'S DIA IS TOO SMALL TO CONTAIN INDIVIDUAL FERRULES IT IS PERMISSIBLE TO TERMINATE 2 SHIELDED WIRES IN THE SAME FERRULE.
-  ALL SHIELDS MUST TERMINATE INSIDE OF EMI BACKSHELL.
-  ALL UNUSED POSITIONS IN CONNECTORS P1 & P2 ARE TO BE FILLED WITH CONTACTS.
16. COMPLETE PART NUMBER FOR THIS ASSEMBLY SHALL INCLUDE APPLICABLE DASH NUMBER INDICATED IN QUANTITY REQUIRED COLUMN.
17. QUANTITY SHOWN IS IN INCHES.

NOTES CONTINUED ON SHEET 2

QTY REQD	QTY REQD	QTY REQD	QTY REQD	FIND NO.	FSCM NO.	PART NUMBER OR IDENTIFYING NO.	NOMENCLATURE OR DESCRIPTION	SPEC/STD	SHEET NO.	NOTE
3	3	3	3	15	80063	A3093335-1	FERRULE, SOLDER			22
22	22	22	22	14	81349	M39029/56-348	CONTACT, CRIMP, SOCKET	MIL-C-39029/56		
8	8	8	8	13	81349	M39029/32-259	CONTACT, CRIMP, SOCKET	MIL-C-39029/32		
1	1	1	1	12	96906	MS3126F12-8S	CONNECTOR, ELECTRICAL, PLUG			
1	1	1	1	11	96906	MS27467T13835S	CONNECTOR, ELECTRICAL, PLUG			
				10						
				9						
2	2	2	2	8	81349	M23053/5-104-0	HEAT SHRINK SLEEVING	MIL-I-23053/5		17
				7						
				6						
REF	REF	REF	REF	5	80063	A3092728	TEST PROCEDURE/DATA SHEET POWER AND SIGNAL CABLE TEST			
				4						
1	1	1	1	3	80063	A3093589-42	BACKSHELL, EMI/RFI			22
1	1	1	1	2	80063	A3092984-4	BACKSHELL, EMI/RFI			22
119	112	107	97	1	80063	A3093563-2	CABLE, ELECTRICAL, SPECIAL PURPOSE			17, 22

PARTS LIST

NOTES CONTINUED FROM SHEET 1

- ▲18 TOLERANCE ON CABLE LENGTH SHALL BE +2, -1 INCHES.
- ▲19 DIMENSIONS SHOWN ON CABLE PREPARATION ILLUSTRATION ARE FOR REFERENCE ONLY.
- ▲20 PLACE HEAT SHRINK SLEEVING, ITEM 8, UNDER SOLDER FERRULE TO PROTECT WIRE.
- ▲21 DELETED.
- 22. VENDOR ITEM - SEE SPECIFICATION CONTROL DRAWING.
- ▲23 DISCARD INNER RING ON BACKSHELL THAT SLIDES ONTO CONNECTOR INSERT.

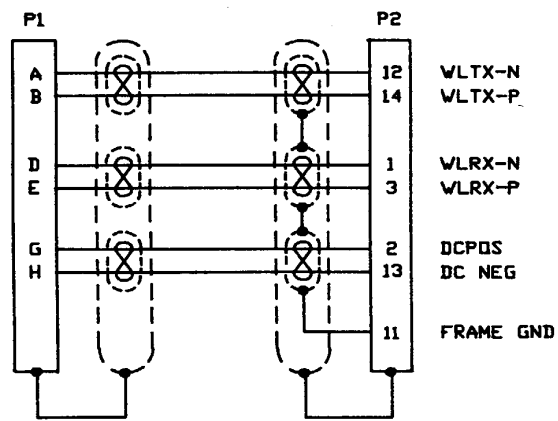
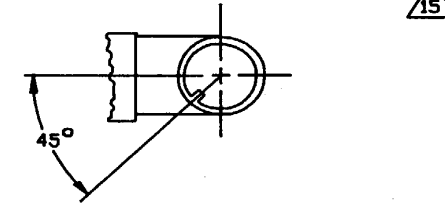
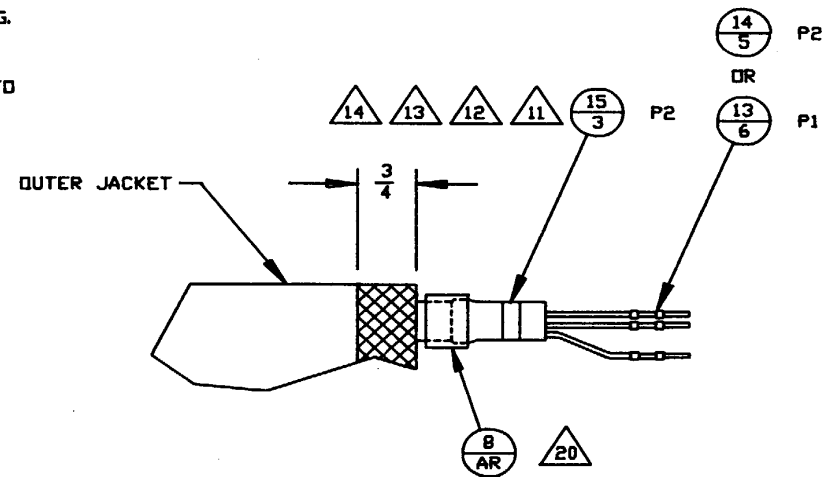
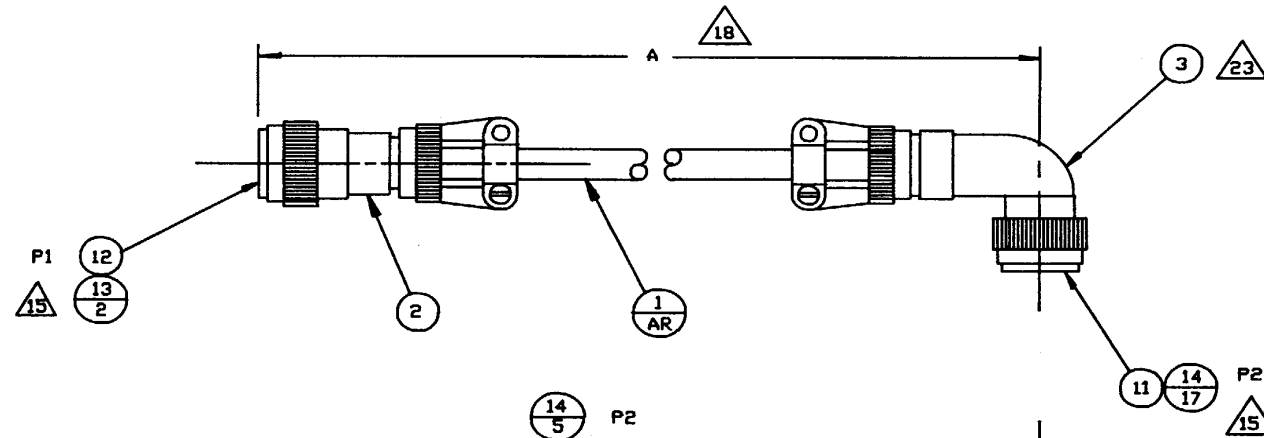

WIRING DIAGRAM

CHART A	
DASH NO.	DIMENSION A
1	97.00
2	107.00
3	112.00
4	119.00

CHART B	
END TYPE	DIMENSION B
P1	0.75 REF
P2	2.00 REF

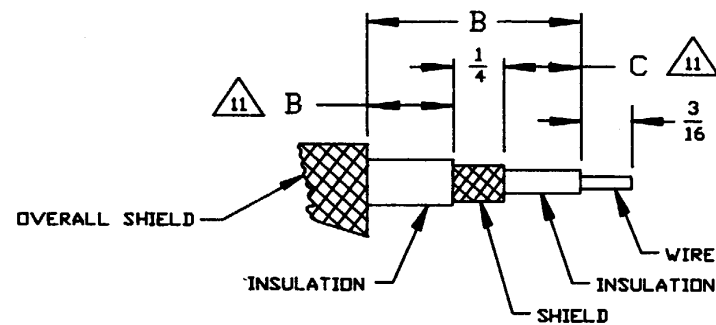

▲19 CABLE PREPARATION

SCALE : 2/1
BOTH ENDS

NOTES :

1. IDENTIFY PART PER MIL-STD-130, TAG.
2. WORKMANSHIP SHALL BE IN ACCORDANCE WITH MIL-STD-454, REQUIREMENT 9.
3. DIMENSIONAL DATA IS BASED ON AMERICAN NATIONAL STANDARD ANSI Y14.5-1973.
4. CRIMP INSERTION TOOL NO. M81969/17-03, REMOVAL TOOL NO. M81969/19-07, PER MIL-I-81969.
5. CRIMPING TOOL NO. M22520/1-01 WITH M22520/1-02 TURRET, PER MIL-C-22520.
6. EACH CONDUCTOR SHALL BE TESTED FOR CONTINUITY AND CORRECT CONNECTIONS BETWEEN ITS TERMINATIONS, USING A POTENTIAL OF NOT MORE THAN 10 VOLTS. CONTINUITY CHECKS SHALL BE MADE FROM CONNECTOR CONTACT TO CONNECTOR CONTACT USING A CONTINUITY TESTER. CONTINUITY POINTS SHALL BE OBTAINED FROM THE CABLE WIRING DIAGRAM. WHERE SHIELD IS BONDED TO CONNECTOR ON BOTH ENDS, THE SHIELD CONTINUITY SHALL BE CHECKED FROM CONNECTOR SHELL TO CONNECTOR SHELL.
7. INSULATION RESISTANCE SHALL BE IN ACCORDANCE WITH METHOD 302 OF MIL-STD-202, TEST CONDITION B. THE POTENTIAL SHALL BE APPLIED BETWEEN EACH CONDUCTOR AND THE REMAINING CONDUCTORS CONNECTED TOGETHER AND TO THE SHIELD, AND CONNECTOR. THE INSULATION RESISTANCE OF THE CABLE ASSEMBLY SHALL NOT BE LESS THAN 100 MEGOHMS. EXCEPT THE INSULATION RESISTANCE OF A SHIELDED CONDUCTOR SHALL NOT BE LESS THAN 30 MEGOHMS.
8. DIELECTRIC WITHSTANDING VOLTAGE. DIELECTRIC STRENGTH SHALL BE PERFORMED IN ACCORDANCE WITH METHOD 301 OF MIL-STD-202. A POTENTIAL OF 500 VOLTS DC SHALL BE APPLIED FOR 30 SECONDS MINIMUM. THE POTENTIAL SHALL BE APPLIED BETWEEN EACH CONDUCTOR AND THE REMAINING CONDUCTORS CONNECTED TOGETHER AND TO THE SHIELD AND CONNECTOR.
9. PARTIAL REFERENCE DESIGNATIONS ARE SHOWN. FOR COMPLETE REFERENCE DESIGNATION, PREFIX WITH UNIT NUMBER AND SUBASSEMBLY DESIGNATION.
10. SOLDERING SHALL BE IN ACCORDANCE WITH MIL-STD-454, REQUIREMENT 5.

- △11 DELETED
- △12 DELETED
- △13 DELETED
- △14 ALL SHIELDS MUST TERMINATE INSIDE OF EMI BACKSHELL.
- △15 ALL UNUSED POSITIONS IN CONNECTORS P1 & P2 ARE TO BE FILLED WITH CONTACTS.
- 16. COMPLETE PART NUMBER FOR THIS ASSEMBLY SHALL INCLUDE APPLICABLE DASH NUMBER INDICATED IN QUANTITY REQUIRED COLUMN.
- 17. QUANTITY SHOWN IS IN INCHES.
- △18 TOLERANCE ON CABLE LENGTH SHALL BE +2, -1 INCHES.
- 19. VENDOR ITEM, SEE SPECIFICATION CONTROL DRAWING.
- △20 DIMENSION SHOWN ON CABLE PREPARATION ILLUSTRATION ARE FOR REFERENCE ONLY.
- △21 DELETED

QTY REQD	QTY REQD	FIND NO.	FSCM NO.	PART NUMBER OR IDENTIFYING NO.	NOMENCLATURE OR DESCRIPTION	SPEC/STD	SHEET NO.	NOTE
		12						
110	110	11	81349	M39029/32-259	CONTACT, CRIMP, SOCKET	MIL-C-309029/32		
2	2	10	96906	MS3126F22-55S	CONNECTOR, ELECTRICAL, PLUG			
		9						
		8						
		7						
		6						
1	1	5	80063	A3092979-8	BACKSHELL, EMI/RFI			19
REF	REF	4	80063	A3092728	TEST PROCEDURE/DATA SHEET POWER AND SIGNAL CABLE TEST			
		3						
1	1	2	80063	A3093589-16	BACKSHELL, EMI/RFI			19
83	77	1	80063	A3093563-16	CABLE, ELECTRICAL, SPECIAL PURPOSE			17 , 19
PARTS LIST								

Cable Assembly, Patch/LGM (Sheet 1 of 2)

A3093607

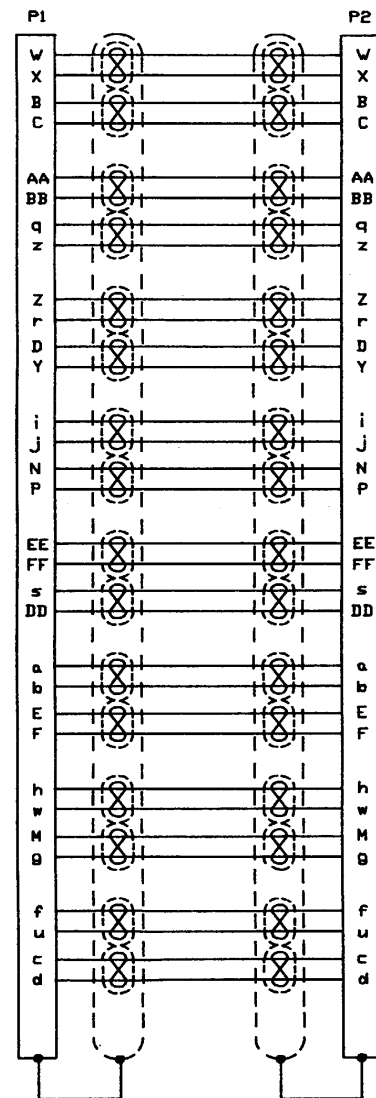

WIRING DIAGRAM

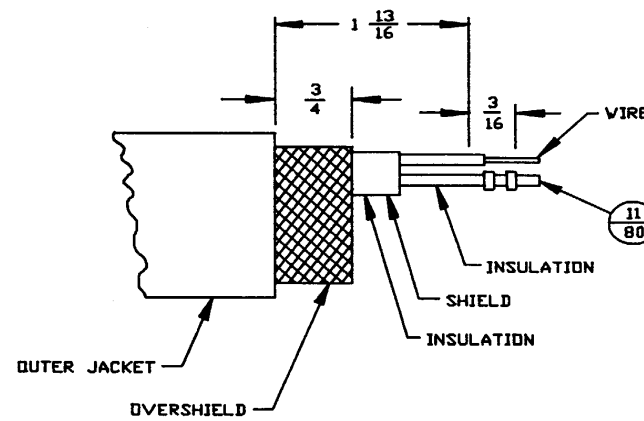
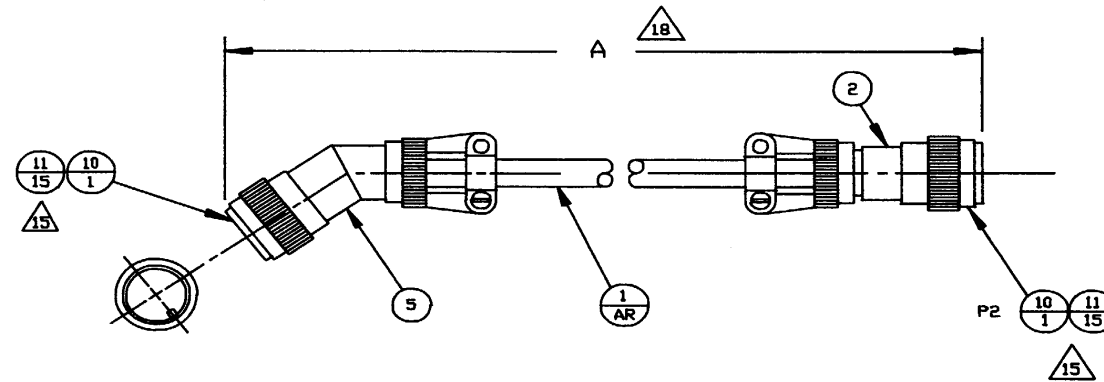

14 20 CABLE PREPARATION

BOTH ENDS

CHART	
DASH NO.	DIMENSION A
1	77.00
2	83.00

NOTES :

1. IDENTIFY PART PER MIL-STD-130, TAG.
2. WORKMANSHIP SHALL BE IN ACCORDANCE WITH MIL-STD-454, REQUIREMENT 9.
3. DIMENSIONAL DATA IS BASED ON AMERICAN NATIONAL STANDARD ANSI Y14.5-1973.
4. CRIMP INSERTION TOOL NO. M81969/17-03, REMOVAL TOOL NO. M81969/19-07, PER MIL-1-81969.
5. CRIMPING TOOL NO. M22520/1-01 WITH M22520/1-02 TURRET, PER MIL-C-22520.
6. EACH CONDUCTOR SHALL BE TESTED FOR CONTINUITY AND CORRECT CONNECTIONS BETWEEN ITS TERMINATIONS, USING A POTENTIAL OF NOT MORE THAN 10 VOLTS. CONTINUITY CHECKS SHALL BE MADE FROM CONNECTOR CONTACT TO CONNECTOR CONTACT USING A CONTINUITY TESTER. CONTINUITY POINTS SHALL BE OBTAINED FROM THE CABLE WIRING DIAGRAM. WHERE SHIELD IS BONDED TO CONNECTOR ON BOTH ENDS, THE SHIELD CONTINUITY SHALL BE CHECKED FROM CONNECTOR SHELL TO CONNECTOR SHELL.
7. INSULATION RESISTANCE SHALL BE IN ACCORDANCE WITH METHOD 302 OF MIL-STD-202, TEST CONDITION B. THE POTENTIAL SHALL BE APPLIED BETWEEN EACH CONDUCTOR AND THE REMAINING CONDUCTORS CONNECTED TOGETHER AND TO THE SHIELD, AND CONNECTOR. THE INSULATION RESISTANCE OF THE CABLE ASSEMBLY SHALL NOT BE LESS THAN 100 MEGOHMS. EXCEPT THE INSULATION RESISTANCE OF A SHIELDED CONDUCTOR SHALL NOT BE LESS THAN 30 MEGOHMS.
8. DIELECTRIC WITHSTANDING VOLTAGE. DIELECTRIC STRENGTH SHALL BE PERFORMED IN ACCORDANCE WITH METHOD 301 OF MIL-STD-202. A POTENTIAL OF 500 VOLTS DC SHALL BE APPLIED FOR 30 SECONDS MINIMUM. THE POTENTIAL SHALL BE APPLIED BETWEEN EACH CONDUCTOR AND THE REMAINING CONDUCTORS CONNECTED TOGETHER AND TO THE SHIELD AND CONNECTOR.
9. PARTIAL REFERENCE DESIGNATIONS ARE SHOWN. FOR COMPLETE REFERENCE DESIGNATION, PREFIX WITH UNIT NUMBER AND SUBASSEMBLY DESIGNATION.
10. SOLDERING SHALL BE IN ACCORDANCE WITH MIL-STD-454, REQUIREMENT 5.

11. DIMENSION B (RANGE 1/4 TO 1/2) AND DIMENSION C (RANGE 1/2 TO 3/4) CAN INCREASE OR DECREASE PROPORTIONALLY TO ALLOW SOLDER FERRULE PLACEMENT TO BE VARIED.
12. INSTALL FERRULES ON SHIELDED TWISTED PAIRS AND SINGLE SHIELDED WIRE STARTING AT 1/2 INCH FROM END OF CONNECTOR AND 3/4 INCH SO FERRULES WILL NOT TERMINATE AT THE SAME LOCATION.
13. WHEN BACKSHELL'S DIAMETER IS TOO SMALL TO CONTAIN INDIVIDUAL FERRULES IT IS PERMISSIBLE TO TERMINATE 2 SHIELDED WIRES IN THE SAME FERRULE.
14. ALL SHIELDS MUST TERMINATE INSIDE OF EMI BACKSHELL.
15. ALL UNUSED POSITIONS IN CONNECTORS P1 & P2 ARE TO BE FILLED WITH CONTACTS.
16. COMPLETE PART NUMBER FOR THIS ASSEMBLY SHALL INCLUDE APPLICABLE DASH NUMBER INDICATED IN QUANTITY REQUIRED COLUMN.
17. QUANTITY SHOWN IS IN INCHES.
18. TOLERANCE ON CABLE LENGTH SHALL BE +2, -1 INCHES.
19. DIMENSION SHOWN ON CABLE PREPARATION ILLUSTRATION ARE FOR REFERENCE ONLY.
20. VENDOR ITEM - SEE SPECIFICATION CONTROL DRAWING.

10	10	10	12	81349	M83519-1-5	FERRULE, SOLDER	MIL-S-83519/1		
36	36	36	11	81349	M39029/32-259	CONTACT, CRIMP, SOCKET	MIL-C-39029/32		
2	2	2	10	96906	MS3126F14-18S	CONNECTOR, ELECTRICAL, PLUG			
			9						
			8						
			7						
			6						
REF	REF	REF	5	80063	A3092728	TEXT PROCEDURE/DATA SHEET POWER AND SIGNAL CABLE TEST			
			4						
			3						
2	2	2	2	80063	A3093589-5	BACKSHELL, EMI/RFI		20	
100	80	67	1	80063	A3093558-4	CABLE, MULTIPLE, DATA BUS, DOUBLE SHIELDED		17 , 20	
QTY REQD	QTY REQD	QTY REQD	FIND NO.	FSCM NO.	PART NUMBER OR IDENTIFYING NO.	NOMENCLATURE OR DESCRIPTION	SPEC/STD	SHEET NO.	NOTE
-3	-2	-1				PARTS LIST			

Cable Assembly, LGM/GM/OCU Patch (Sheet 1 of 2)

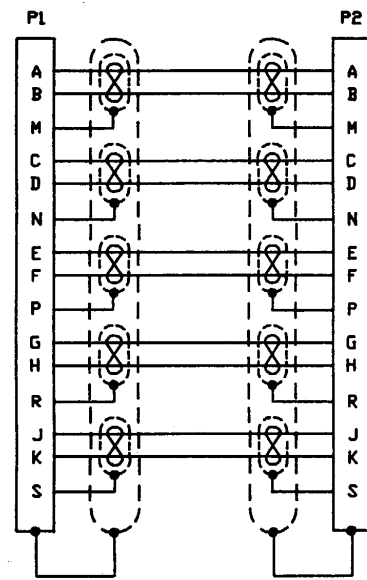

WIRING DIAGRAM

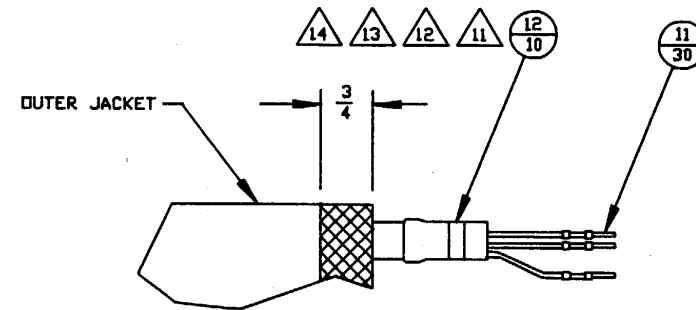
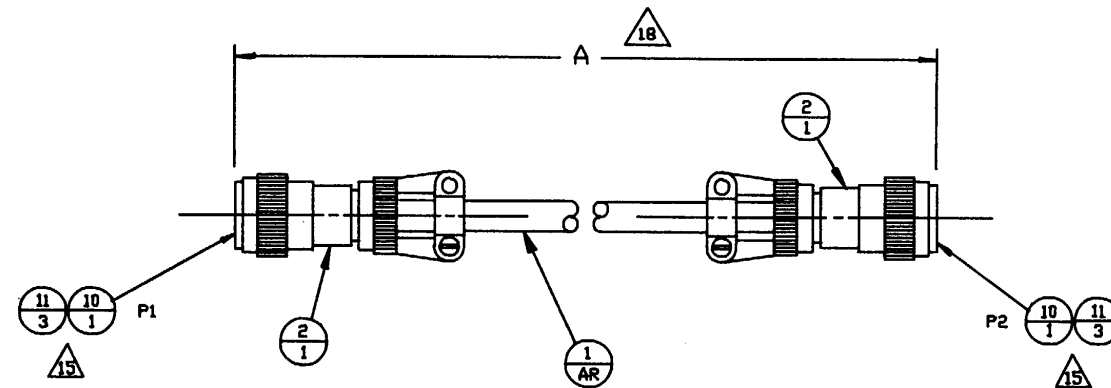
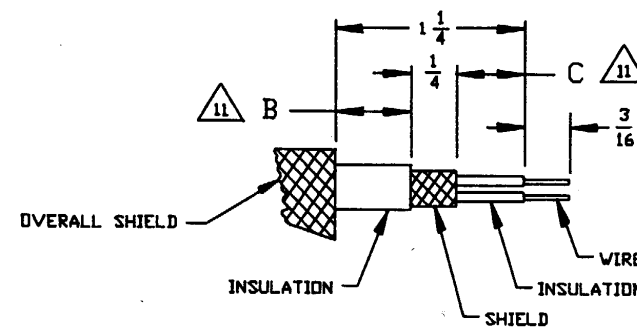

CHART	
DASH NO.	DIMENSION A
1	67.00
2	80.00
3	100.00





19 CABLE PREPARATION

BOTH ENDS

NOTES :

1. IDENTIFY PART PER MIL-STD-130, TAG.
2. WORKMANSHIP SHALL BE IN ACCORDANCE WITH MIL-STD-454, REQUIREMENT 9.
3. DIMENSIONAL DATA IS BASED ON AMERICAN NATIONAL STANDARD ANSI Y14.5-1973.
4. CRIMP INSERTION TOOL NO. M81969/17-03, REMOVAL TOOL NO. M81969/19-07, PER MIL-I-81969.
5. CRIMPING TOOL NO. M22520/1-01 WITH M22520/1-02 TURRET, PER MIL-C-22520.
6. EACH CONDUCTOR SHALL BE TESTED FOR CONTINUITY AND CORRECT CONNECTIONS BETWEEN ITS TERMINATIONS, USING A POTENTIAL OF NOT MORE THAN 10 VOLTS. CONTINUITY CHECKS SHALL BE MADE FROM CONNECTOR CONTACT TO CONNECTOR CONTACT USING A CONTINUITY TESTER. CONTINUITY POINTS SHALL BE OBTAINED FROM THE CABLE WIRING DIAGRAM. WHERE SHIELD IS BONDED TO CONNECTOR ON BOTH ENDS, THE SHIELD CONTINUITY SHALL BE CHECKED FROM CONNECTOR SHELL TO CONNECTOR SHELL.
7. INSULATION RESISTANCE SHALL BE IN ACCORDANCE WITH METHOD 302 OF MIL-STD-202, TEST CONDITION B. THE POTENTIAL SHALL BE APPLIED BETWEEN EACH CONDUCTOR AND THE REMAINING CONDUCTORS CONNECTED TOGETHER AND TO THE SHIELD, AND CONNECTOR. THE INSULATION RESISTANCE OF THE CABLE ASSEMBLY SHALL NOT BE LESS THAN 100 MEGOHMS. EXCEPT THE INSULATION RESISTANCE OF A SHIELDED CONDUCTOR SHALL NOT BE LESS THAN 30 MEGOHMS.
8. DIELECTRIC WITHSTANDING VOLTAGE. DIELECTRIC STRENGTH SHALL BE PERFORMED IN ACCORDANCE WITH METHOD 301 OF MIL-STD-202. A POTENTIAL OF 500 VOLTS DC SHALL BE APPLIED FOR 30 SECONDS MINIMUM. THE POTENTIAL SHALL BE APPLIED BETWEEN EACH CONDUCTOR AND THE REMAINING CONDUCTORS CONNECTED TOGETHER AND TO THE SHIELD AND CONNECTOR.
9. PARTIAL REFERENCE DESIGNATIONS ARE SHOWN. FOR COMPLETE REFERENCE DESIGNATION, PREFIX WITH UNIT NUMBER AND SUBASSEMBLY DESIGNATION.
10. SOLDERING SHALL BE IN ACCORDANCE WITH MIL-STD-454, REQUIREMENT 5.

 ALL UNUSED POSITIONS IN CONNECTORS P1 & P2 ARE TO BE FILLED WITH CONTACTS.

12. COMPLETE PART NUMBER FOR THIS ASSEMBLY SHALL INCLUDE APPLICABLE DASH NUMBER INDICATED IN QUANTITY REQUIRED COLUMN.
13. QUANTITY SHOWN IS IN INCHES.
-  TOLERANCE ON CABLE LENGTH SHALL BE +2, -1 INCHES.
15. VENDOR ITEM - SEE SPECIFICATION CONTROL DRAWING.
-  DIMENSIONS SHOWN ON CABLE PREPARATION ILLUSTRATION ARE FOR REFERENCE ONLY.

2	2	11	96906	MS3126F12-10P	CONNECTOR, ELECTRICAL, PLUG			
20	20	10	81349	M39029/31-240	CONTACT, CRIMP, PINS	MIL-C-39029/31		
		9						
		8						
		7						
		6						
1	1	5	80063	A3092984-3	BACKSHELL, EMI/RFI			15
REF	REF	4	80063	A3092728	TEST PROCEDURE/DATA SHEET POWER AND SIGNAL CABLE TEST			
		3						
1	1	2	80063	A3093589-2	BACKSHELL, EMI/RFI			15
110	125	1	80063	A3093562-9	CABLE, ELECTRICAL, SPECIAL PURPOSE			13 , 15
QTY REQD	QTY REQD	FIND NO.	FSCM NO.	PART NUMBER OR IDENTIFYING NO.	NOMENCLATURE OR DESCRIPTION	SPEC/STD	SHEET NO.	NOTE
-2	-1				PARTS LIST			

Cable Assembly, GM (ROA)/Patch (Sheet 1 of 2)

A3093609

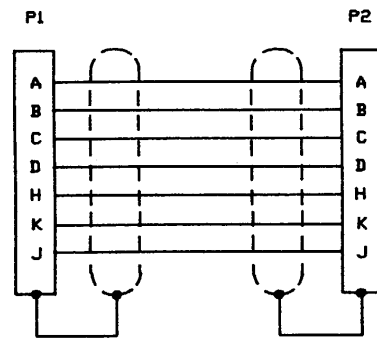

WIRING DIAGRAM

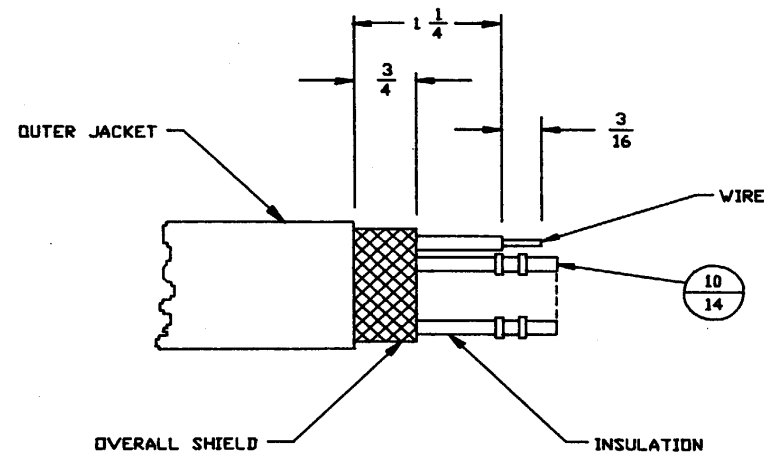
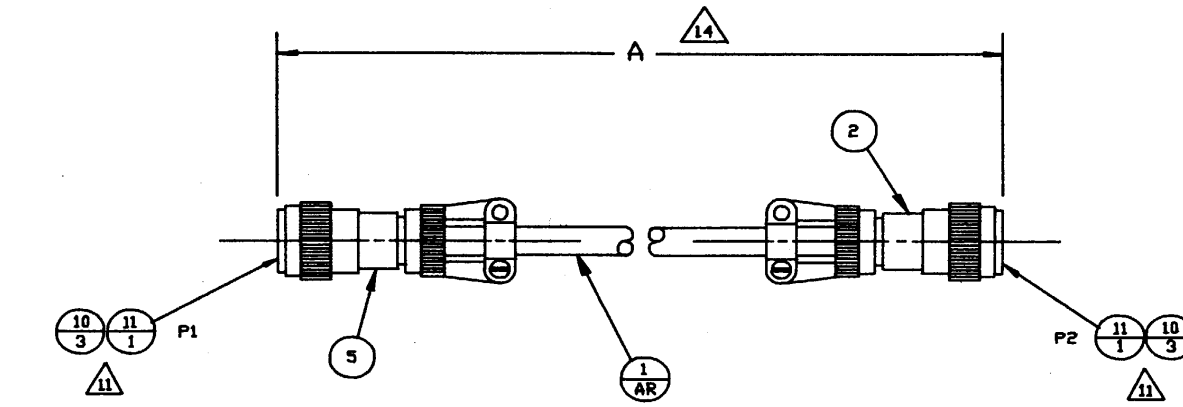

CABLE PREPARATION 16

SCALE : 2/1
BOTH ENDS

CHART	
DASH NO.	DIMENSION A
1	125.00
2	110.00

NOTES :

1. IDENTIFY PART PER MIL-STD-130, TAG.
2. WORKMANSHIP SHALL BE IN ACCORDANCE WITH MIL-STD-454, REQUIREMENT 9.
3. DIMENSIONAL DATA IS BASED ON AMERICAN NATIONAL STANDARD ANSI Y14.5-1973.
4. EACH CONDUCTOR SHALL BE TESTED FOR CONTINUITY AND CORRECT CONNECTIONS BETWEEN ITS TERMINATIONS, USING A POTENTIAL OF NOT MORE THAN 10 VOLTS. CONTINUITY CHECKS SHALL BE MADE FROM CONNECTOR CONTACT TO CONNECTOR CONTACT USING A CONTINUITY TESTER. CONTINUITY POINTS SHALL BE OBTAINED FROM THE CABLE WIRING DIAGRAM. WHERE SHIELD IS BONDED TO CONNECTOR ON BOTH ENDS, THE SHIELD CONTINUITY SHALL BE CHECKED FROM CONNECTOR SHELL TO CONNECTOR SHELL.
5. INSULATION RESISTANCE SHALL BE IN ACCORDANCE WITH METHOD 302 OF MIL-STD-202, TEST CONDITION B. THE POTENTIAL SHALL BE APPLIED BETWEEN EACH CONDUCTOR AND THE REMAINING CONDUCTORS CONNECTED TOGETHER AND TO THE SHIELD, AND CONNECTOR. THE INSULATION RESISTANCE OF THE CABLE ASSEMBLY SHALL NOT BE LESS THAN 100 MEGOHMS, EXCEPT THE INSULATION RESISTANCE OF A SHIELDED CONDUCTOR SHALL NOT BE LESS THAN 30 MEGOHMS.
6. DIELECTRIC WITHSTAND VOLTAGE. DIELECTRIC STRENGTH SHALL BE PERFORMED IN ACCORDANCE WITH METHOD 301 OF MIL-STD-202. A POTENTIAL OF 500 VOLTS DC SHALL BE APPLIED FOR 30 SECONDS MINIMUM. THE POTENTIAL SHALL BE APPLIED BETWEEN EACH CONDUCTOR AND THE REMAINING CONDUCTORS CONNECTED TOGETHER AND TO THE SHIELD AND CONNECTOR.
7. PARTIAL REFERENCE DESIGNATION ARE SHOWN. FOR COMPLETE REFERENCE DESIGNATION, PREFIX WITH UNIT NUMBER AND SUBASSEMBLY DESIGNATION.
8. SOLDERING SHALL BE IN ACCORDANCE WITH MIL-STD-454, REQUIREMENT 5.
9. QUANTITY SHOWN IS IN INCHES.
- \triangle TOLERANCE ON CABLE LENGTH SHALL BE +2, -1 INCHES.
11. VENDOR ITEM - SEE SPECIFICATION CONTROL DRAWING.

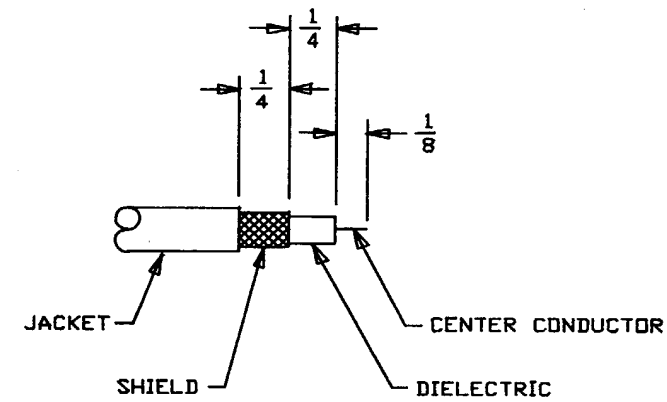
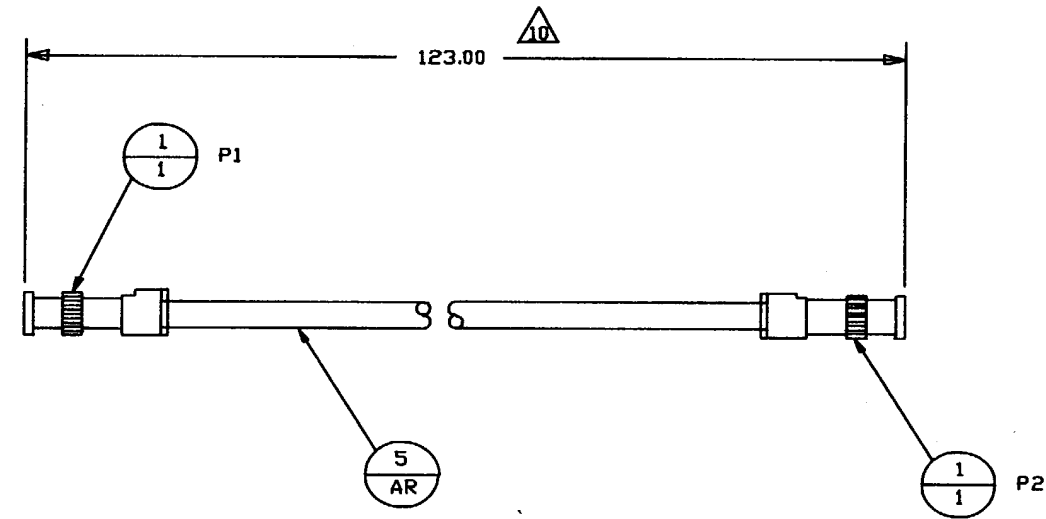

CABLE PREPARATION

BOTH ENDS

123	5	81349	M17/028-RG058	CABLE, COAX	MIL-C-17/28		9
REF	4	80063	A3092728	TEST PROCEDURE/DATA SHEET POWER AND SIGNAL CABLE TEST			
	3						
	2						
	2	80063	A3093567-2	CONNECTOR, RF			11
QTY REQD	FIND NO.	FSCM NO.	PART NUMBER OR IDENTIFYING NO.	NOMENCLATURE OR DESCRIPTION	SPEC/STD	SHEET NO.	NOTE
PARTS LIST							

Cable Assembly, Line Data Out

NOTES :

1. IDENTIFY PART PER MIL-STD-130, TAG.
2. WORKMANSHIP SHALL BE IN ACCORDANCE WITH MIL-STD-454, REQUIREMENT 9.
3. DIMENSIONAL DATA IS BASED ON AMERICAN NATIONAL STANDARD ANSI Y14.5-1973.
4. EACH CONDUCTOR SHALL BE TESTED FOR CONTINUITY AND CORRECT CONNECTIONS BETWEEN ITS TERMINATIONS, USING A POTENTIAL OF NOT MORE THAN 10 VOLTS. CONTINUITY CHECKS SHALL BE MADE FROM CONNECTOR CONTACT TO CONNECTOR CONTACT USING A CONTINUITY TESTER. CONTINUITY POINTS SHALL BE OBTAINED FROM THE CABLE WIRING DIAGRAM. WHERE SHIELD IS BONDED TO CONNECTOR ON BOTH ENDS, THE SHIELD CONTINUITY SHALL BE CHECKED FROM CONNECTOR SHELL TO CONNECTOR SHELL.
5. INSULATION RESISTANCE SHALL BE IN ACCORDANCE WITH METHOD 302 OF MIL-STD-202, TEST CONDITION B. THE POTENTIAL SHALL BE APPLIED BETWEEN EACH CONDUCTOR AND THE REMAINING CONDUCTORS CONNECTED TOGETHER AND TO THE SHIELD, AND CONNECTOR. THE INSULATION RESISTANCE OF THE CABLE ASSEMBLY SHALL NOT BE LESS THAN 100 MEGOHMS, EXCEPT THE INSULATION RESISTANCE OF A SHIELDED CONDUCTOR SHALL NOT BE LESS THAN 30 MEGOHMS.
6. DIELECTRIC WITHSTAND VOLTAGE. DIELECTRIC STRENGTH SHALL BE PERFORMED IN ACCORDANCE WITH METHOD 301 OF MIL-STD-202. A POTENTIAL OF 500 VOLTS DC SHALL BE APPLIED FOR 30 SECONDS MINIMUM. THE POTENTIAL SHALL BE APPLIED BETWEEN EACH CONDUCTOR AND THE REMAINING CONDUCTORS CONNECTED TOGETHER AND TO THE SHIELD AND CONNECTOR.
7. PARTIAL REFERENCE DESIGNATION ARE SHOWN. FOR COMPLETE REFERENCE DESIGNATION, PREFIX WITH UNIT NUMBER AND SUBASSEMBLY DESIGNATION.
8. SOLDERING SHALL BE IN ACCORDANCE WITH MIL-STD-454, REQUIREMENT 5.
9. QUANTITY SHOWN IS IN INCHES.
- \triangle TOLERANCE ON CABLE LENGTH SHALL BE +2, -1 INCHES.
11. VENDOR ITEM - SEE SPECIFICATION CONTROL DRAWING.

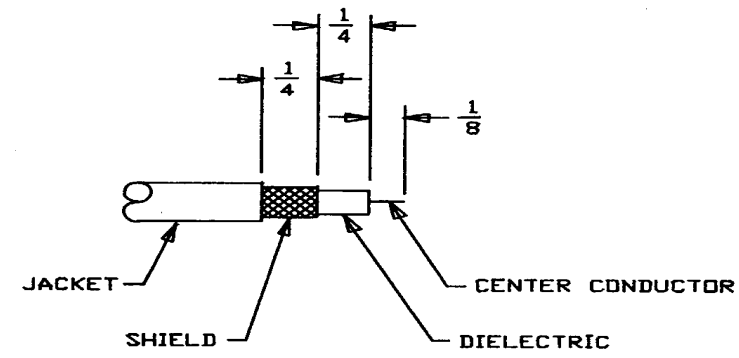
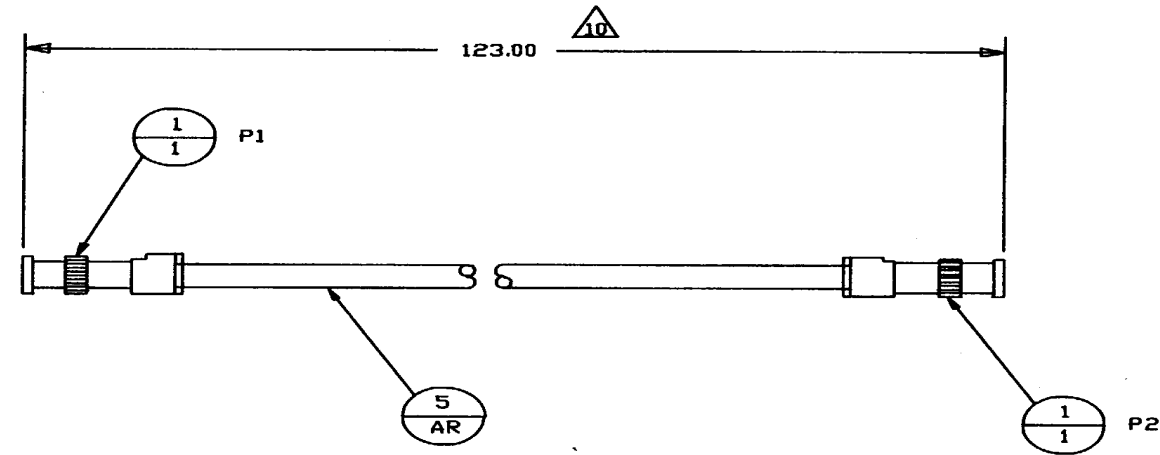

CABLE PREPARATION

BOTH ENDS

123	5	81349	M17/028-RG058	CABLE, COAX	MIL-C-17/28		9
REF	4	80063	A3092728	TEST PROCEDURE/DATA SHEET POWER AND SIGNAL CABLE TEST			
	3						
	2						
2	1	80063	A3093567-2	CONNECTOR, RF			11
QTY REQD	FIND NO.	FSCM NO.	PART NUMBER OR IDENTIFYING NO.	NOMENCLATURE OR DESCRIPTION	SPEC/STD	SHEET NO.	NOTE
PARTS LIST							

Cable Assembly, Line Data In

NOTES :

1. IDENTIFY PART PER MIL-STD-130, TAG.
2. WORKMANSHIP SHALL BE IN ACCORDANCE WITH MIL-STD-454, REQUIREMENT 9.
3. DIMENSIONAL DATA IS BASED ON AMERICAN NATIONAL STANDARD ANSI Y14.5-1973.
4. CRIMP INSERTION TOOL NO. M81969/8-01, REMOVAL TOOL NO. M81969/8-02.
5. CRIMPING TOOL NO. M22520/2-01 WITH M22520/2-07 TURRET.
6. EACH CONDUCTOR SHALL BE TESTED FOR CONTINUITY AND CORRECT CONNECTIONS BETWEEN ITS TERMINATIONS, USING A POTENTIAL OF NOT MORE THAN 10 VOLTS. CONTINUITY CHECKS SHALL BE MADE FROM CONNECTOR CONTACT TO CONNECTOR CONTACT USING A CONTINUITY TESTER. CONTINUITY POINTS SHALL BE OBTAINED FROM THE CABLE WIRING DIAGRAM. WHERE SHIELD IS BONDED TO CONNECTOR ON BOTH ENDS, THE SHIELD CONTINUITY SHALL BE CHECKED FROM CONNECTOR SHELL TO CONNECTOR SHELL.
7. INSULATION RESISTANCE SHALL BE IN ACCORDANCE WITH METHOD 302 OF MIL-STD-202, TEST CONDITION B. THE POTENTIAL SHALL BE APPLIED BETWEEN EACH CONDUCTOR AND THE REMAINING CONDUCTORS CONNECTED TOGETHER AND TO THE SHIELD, AND CONNECTOR. THE INSULATION RESISTANCE OF THE CABLE ASSEMBLY SHALL NOT BE LESS THAN 100 MEGOHMS. EXCEPT THE INSULATION RESISTANCE OF A SHIELDED CONDUCTOR SHALL NOT BE LESS THAN 30 MEGOHMS.
8. DIELECTRIC WITHSTANDING VOLTAGE. DIELECTRIC STRENGTH SHALL BE PERFORMED IN ACCORDANCE WITH METHOD 301 OF MIL-STD-202. A POTENTIAL OF 500 VOLTS DC SHALL BE APPLIED FOR 30 SECONDS MINIMUM. THE POTENTIAL SHALL BE APPLIED BETWEEN EACH CONDUCTOR AND THE REMAINING CONDUCTORS CONNECTED TOGETHER AND TO THE SHIELD AND CONNECTOR.
9. PARTIAL REFERENCE DESIGNATIONS ARE SHOWN. FOR COMPLETE REFERENCE DESIGNATION, PREFIX WITH UNIT NUMBER AND SUBASSEMBLY DESIGNATION.
10. SOLDERING SHALL BE IN ACCORDANCE WITH MIL-STD-454, REQUIREMENT 5.
11. THIS NOTE LEFT BLANK.

12. THIS NOTE LEFT BLANK.
13. THIS NOTE LEFT BLANK.
- △4 ALL SHIELDS MUST TERMINATE INSIDE OF EMI BACKSHELL.
- △5 QUANTITY SHOWN IS IN INCHES.
- △6 TOLERANCE ON CABLE LENGTH SHALL BE +2, -1 INCHES.
- △7 VENDOR ITEM - SEE SPECIFICATION CONTROL DRAWING.
- △8 DIMENSIONS SHOWN ON CABLE PREPARATION ILLUSTRATION ARE FOR REFERENCE ONLY.
- △9 STRIP LENGTHS FOR BOTH ENDS ARE IDENTICAL, HOWEVER P1 END IS SOLDERED TO PINS THAT ARE A PART OF THE CONNECTOR.

1	14	81349	U290/U	CONNECTOR, ELECTRICAL, PLUG	MIL-C-55116		
	13						
1	12	81349	MS27467T11B35S	CONNECTOR, ELECTRICAL, PLUG	MIL-C-38999		
1	11	81349	M85049/17-10W03	BACKSHELL, EMI/RFI	MIL-C-85049		
	10						
13	9	81349	M39029/56-348	CONTACT, CRIMP, SOCKET	MIL-C-39029/56		
	8						
	7						
	6						
REF	5	80063	A3092728	TEST PROCEDURE/DATA SHEET POWER AND SIGNAL CABLE TEST			
	4						
52	3	80063	A3093562-9	CABLE, ELECTRICAL, SPECIAL PURPOSE			15 , 17
1	2	80063	A3093478-1	BACKSHELL, EMI/RFI			17
	1						
QTY REQD	FIND NO.	FSCM NO.	PART NUMBER OR IDENTIFYING NO.	NOMENCLATURE OR DESCRIPTION	SPEC/STD	SHEET NO.	NOTE
PARTS LIST							

Cable Assembly, Entry/Antenna Control (Sheet 1 of 2)

A3093616

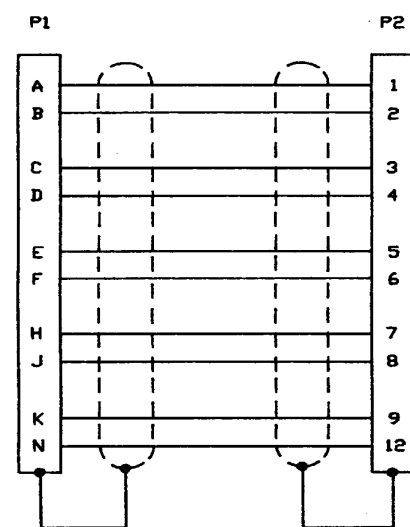

WIRING DIAGRAM

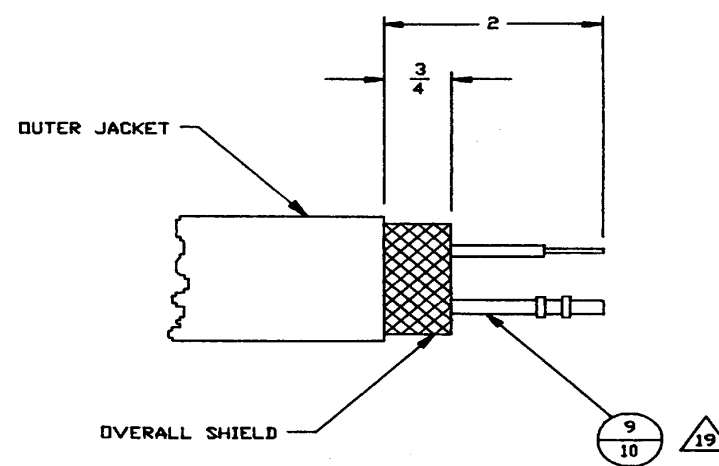
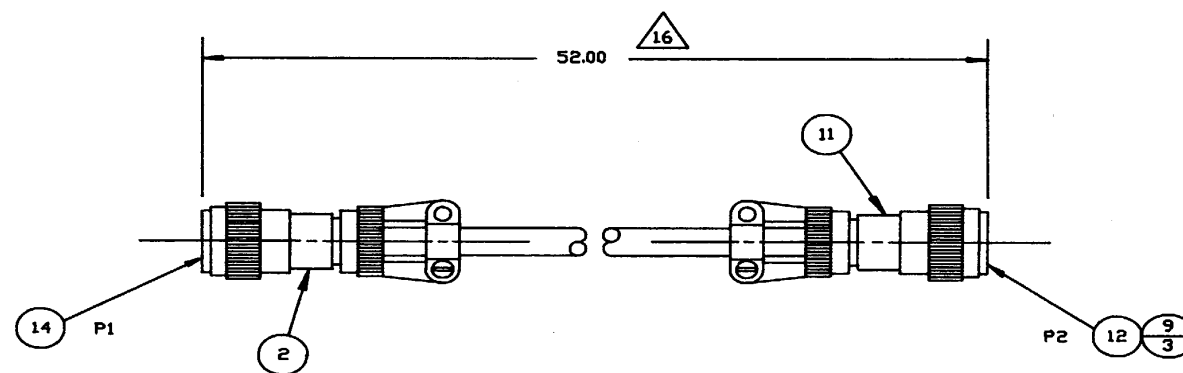

△ 14 △ 18 CABLE PREPARATION

SCALE : NONE
BOTH ENDS

NOTES :

1. IDENTIFY PART PER MIL-STD-130, TAG.
2. WORKMANSHIP SHALL BE IN ACCORDANCE WITH MIL-STD-454, REQUIREMENT 9.
3. DIMENSIONAL DATA IS BASED ON AMERICAN NATIONAL STANDARD ANSI Y14.5-1973.
4. COAXIAL CONTACT INSERTION TOOL NO. M81969/8-07, REMOVAL TOOL NO. M81969/8-08; CONTACT INSERTION / REMOVAL TOOL NO. M81969/14-03.
5. CRIMP TOOL FOR COAXIAL CONTACTS: INNER CONTACT M22520/2-01, POSITIONER M22520/2-35, FERRULE NO. M22520/4-01, POSITIONER M22520/4-02; FOR NORMAL CONTACTS USE CRIMP TOOL M22520/1-01, POSITIONER M22520/1-04.
6. EACH CONDUCTOR SHALL BE TESTED FOR CONTINUITY AND CORRECT CONNECTIONS BETWEEN ITS TERMINATIONS, USING A POTENTIAL OF NOT MORE THAN 10 VOLTS. CONTINUITY CHECKS SHALL BE MADE FROM CONNECTOR CONTACT TO CONNECTOR CONTACT USING A CONTINUITY TESTER. CONTINUITY POINTS SHALL BE OBTAINED FROM THE CABLE WIRING DIAGRAM. WHERE SHIELD IS BONDED TO CONNECTOR ON BOTH ENDS, THE SHIELD CONTINUITY SHALL BE CHECKED FROM CONNECTOR SHELL TO CONNECTOR SHELL.
7. INSULATION RESISTANCE SHALL BE IN ACCORDANCE WITH METHOD 302 OF MIL-STD-202, TEST CONDITION B. THE POTENTIAL SHALL BE APPLIED BETWEEN EACH CONDUCTOR AND THE REMAINING CONDUCTORS CONNECTED TOGETHER AND TO THE SHIELD, AND CONNECTOR. THE INSULATION RESISTANCE OF THE CABLE ASSEMBLY SHALL NOT BE LESS THAN 100 MEGOHMS. EXCEPT THE INSULATION RESISTANCE OF A SHIELDED CONDUCTOR SHALL NOT BE LESS THAN 30 MEGOHMS.
8. DIELECTRIC WITHSTANDING VOLTAGE. DIELECTRIC STRENGTH SHALL BE PERFORMED IN ACCORDANCE WITH METHOD 301 OF MIL-STD-202. A POTENTIAL OF 500 VOLTS DC SHALL BE APPLIED FOR 30 SECONDS MINIMUM. THE POTENTIAL SHALL BE APPLIED BETWEEN EACH CONDUCTOR AND THE REMAINING CONDUCTORS CONNECTED TOGETHER AND TO THE SHIELD AND CONNECTOR.
9. PARTIAL REFERENCE DESIGNATIONS ARE SHOWN. FOR COMPLETE REFERENCE DESIGNATION, PREFIX WITH UNIT NUMBER AND SUBASSEMBLY DESIGNATION.
10. SOLDERING SHALL BE IN ACCORDANCE WITH MIL-STD-454, REQUIREMENT 5.

11. DELETED

12. QUANTITY SHOWN IS IN INCHES.

 TOLERANCE ON CABLE LENGTH SHALL BE +2, -1 INCHES.

 DIMENSIONS SHOWN ON CABLE PREPARATION ILLUSTRATION ARE FOR REFERENCE ONLY.

15. VENDOR ITEM - SEE SPECIFICATION CONTROL DRAWING.

 REMOVE EXISTING SCREWS (2) AND REPLACE WITH ITEM 8.

2	13	96906	MS27473T1688B	CONNECTOR, ELECTRICAL, PLUG			
4	12	81349	M39029/78-432	CONTACT, CRIMP, SOCKET	MIL-C-39029/76		
12	11	81349	M309029/57-358	CONTACT, CRIMP, SOCKET	MIL-C-39029/58		
	10						
	9						
2	8	96906	MS51957-32	SCREW, PPH 6-32 X 3/4 L			
	7						
	6						
REF	5	80063	A3092728	TEST PROCEDURE/DATA SHEET POWER AND SIGNAL CABLE TEST			
2	4	96906	MS35338-136	WASHER, LOCK, SPLIT NO. 6			
1	3	80063	A3093589-59	BACKSHELL, EMI/RFI			15
1	2	80063	A3092983-5	BACKSHELL, EMI/RFI			15
166	1	80063	A3093561	CABLE ELECTRICAL, SPECIAL PURPOSE			12 , 15
QTY REQD	FIND NO.	FSCM NO.	PART NUMBER OR IDENTIFYING NO.	NOMENCLATURE OR DESCRIPTION	SPEC/STD	SHEET NO.	NOTE
PARTS LIST							

A3093617

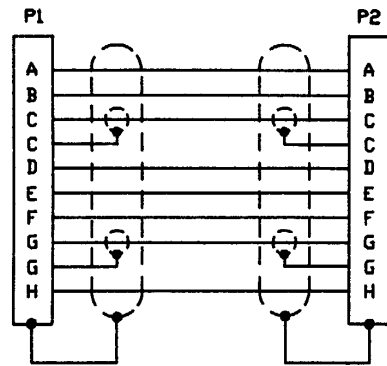

WIRING DIAGRAM

CHART A	
END TYPE	DIMENSION A
P1	1.25 REF
P2	3.50 REF

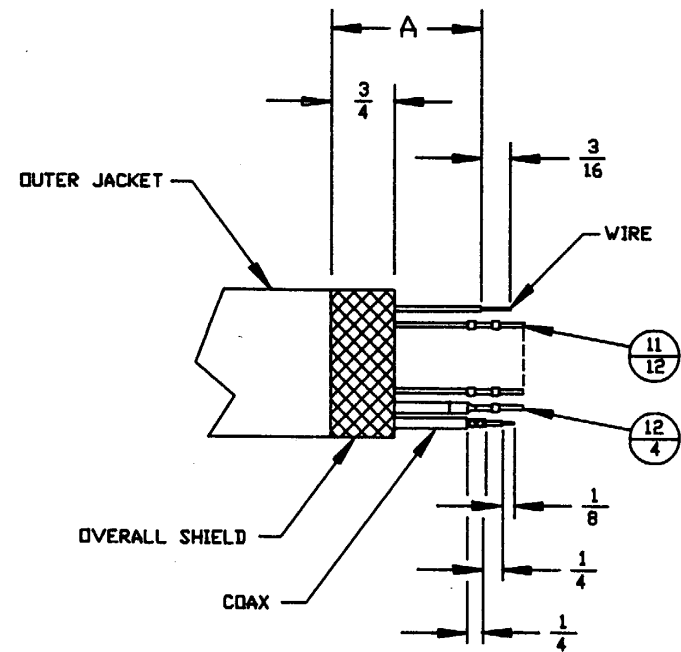
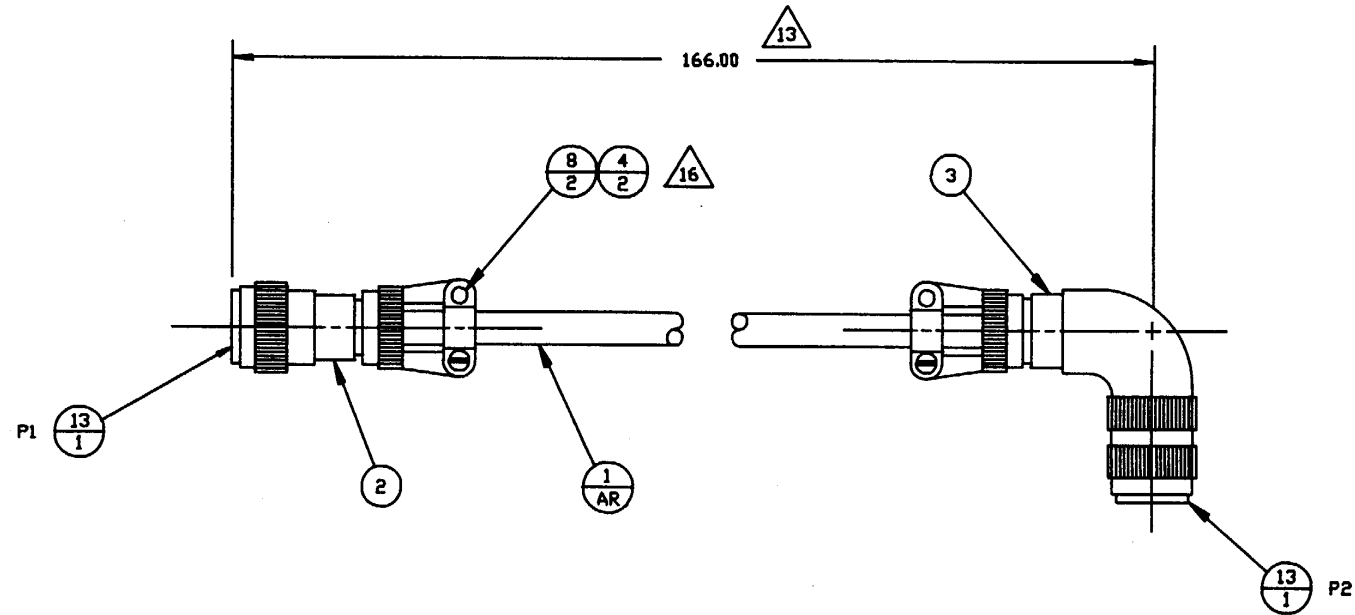

14 CABLE PREPARATION

SCALE : 2/1
BOTH ENDS

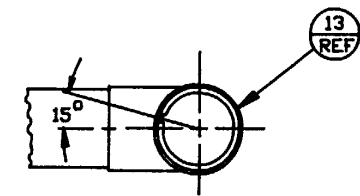

NOTES :

1. IDENTIFY PART PER MIL-STD-130, TAG.
2. WORKMANSHIP SHALL BE IN ACCORDANCE WITH MIL-STD-454, REQUIREMENT 9.
3. DIMENSIONAL DATA IS BASED ON AMERICAN NATIONAL STANDARD ANSI Y14.5-1973.
4. CRIMP INSERTION AND REMOVAL TOOL NO. M81969/14-01, PER MIL-I-81969.
5. CRIMPING TOOL NO. M22520/2-01 WITH M22520/2-07 TURRET, PER MIL-C-22520.
6. EACH CONDUCTOR SHALL BE TESTED FOR CONTINUITY AND CORRECT CONNECTIONS BETWEEN ITS TERMINATIONS, USING A POTENTIAL OF NOT MORE THAN 10 VOLTS. CONTINUITY CHECKS SHALL BE MADE FROM CONNECTOR CONTACT TO CONNECTOR CONTACT USING A CONTINUITY TESTER. CONTINUITY POINTS SHALL BE OBTAINED FROM THE CABLE WIRING DIAGRAM. WHERE SHIELD IS BONDED TO CONNECTOR ON BOTH ENDS, THE SHIELD CONTINUITY SHALL BE CHECKED FROM CONNECTOR SHELL TO CONNECTOR SHELL.
7. INSULATION RESISTANCE SHALL BE IN ACCORDANCE WITH METHOD 302 OF MIL-STD-202, TEST CONDITION B. THE POTENTIAL SHALL BE APPLIED BETWEEN EACH CONDUCTOR AND THE REMAINING CONDUCTORS CONNECTED TOGETHER AND TO THE SHIELD, AND CONNECTOR. THE INSULATION RESISTANCE OF THE CABLE ASSEMBLY SHALL NOT BE LESS THAN 100 MEGOHMS. EXCEPT THE INSULATION RESISTANCE OF A SHIELDED CONDUCTOR SHALL NOT BE LESS THAN 30 MEGOHMS.
8. DIELECTRIC WITHSTANDING VOLTAGE. DIELECTRIC STRENGTH SHALL BE PERFORMED IN ACCORDANCE WITH METHOD 301 OF MIL-STD-202. A POTENTIAL OF 500 VOLTS DC SHALL BE APPLIED FOR 30 SECONDS MINIMUM. THE POTENTIAL SHALL BE APPLIED BETWEEN EACH CONDUCTOR AND THE REMAINING CONDUCTORS CONNECTED TOGETHER AND TO THE SHIELD AND CONNECTOR.
9. PARTIAL REFERENCE DESIGNATIONS ARE SHOWN. FOR COMPLETE REFERENCE DESIGNATION, PREFIX WITH UNIT NUMBER AND SUBASSEMBLY DESIGNATION.
10. SOLDERING SHALL BE IN ACCORDANCE WITH MIL-STD-454, REQUIREMENT 5.
- △ ALL UNUSED POSITIONS IN CONNECTORS P1 & P2 ARE TO BE FILLED WITH CONTACTS.
12. QUANTITY SHOWN IS IN INCHES.
- △ TOLERANCE ON CABLE LENGTH SHALL BE +2,-1 INCHES.
- △ DIMENSIONS SHOWN ON CABLE PREPARATION ILLUSTRATION ARE FOR REFERENCE ONLY.
- △ PLACE HEAT SHRINK SLEEVING, ITEM 6, UNDER SOLDER FERRULE TO PROTECT WIRE.
16. VENDOR ITEM, SEE SPECIFICATION CONTROL DRAWING.
17. COMPLETE PART NUMBER FOR THIS ASSEMBLY SHALL INCLUDE APPLICABLE DASH NUMBER INDICATED IN QUANTITY REQUIRED COLUMN.

110	110	110	110	110	110	110	110	110	12	81349	M39029/56-348	CRIMP CONTACTS, SOCKET	MIL-C-39029/56					
2	2	2	2	2	2	2	2	2	11	96906	MS27467T17B35S	CONNECTOR, ELECTRICAL, RECEPTACLE						
									10									
12	12	12	12	12	12	12	12	12	9	81349	M83159-1-2	FERRULE, SOLDER	MIL-S-83519					
									8									
									7									
14	14	14	14	14	14	14	14	14	6	81349	M23053/5-104-0	HEAT SHRINK SLEEVING	MIL-I-23053/5	12				
REF	REF	REF	REF	REF	REF	REF	REF	REF	5	80063	A3092728	TEST PROCEDURE/DATA SHEET POWER AND SIGNAL CABLE TEST						
									4									
1	1	1	1	1	1	1	1	1	3	80063	A3092988-5	BACKSHELL, EMI/RFI			16			
182	182	352	75	282	364	293	110	97	2	80063	A3093588	CABLE, ELECTRICAL, SPECIAL PURPOSE			12 , 16			
1	1	1	1	1	1	1	1	1	1	80063	A3093577-6	BACKSHELL, EMI/RFI			16			
QTY REQD	QTY REQD	QTY REQD	QTY REQD	QTY REQD	QTY REQD	QTY REQD	QTY REQD	QTY REQD	FIND NO.	FSCM NO.	PART NUMBER OR IDENTIFYING NO.	NOMENCLATURE OR DESCRIPTION	SPEC/STD	SHEET NO.	NOTE			
-9	-8	-7	-6	-5	-4	-3	-2	-1	PARTS LIST									

A3093620

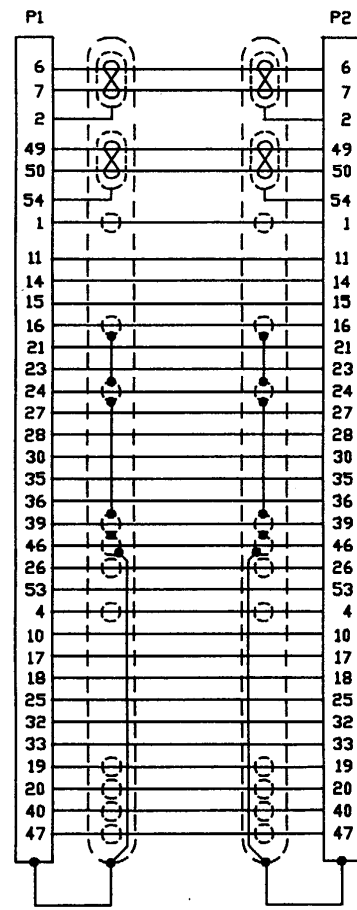

WIRING DIAGRAM

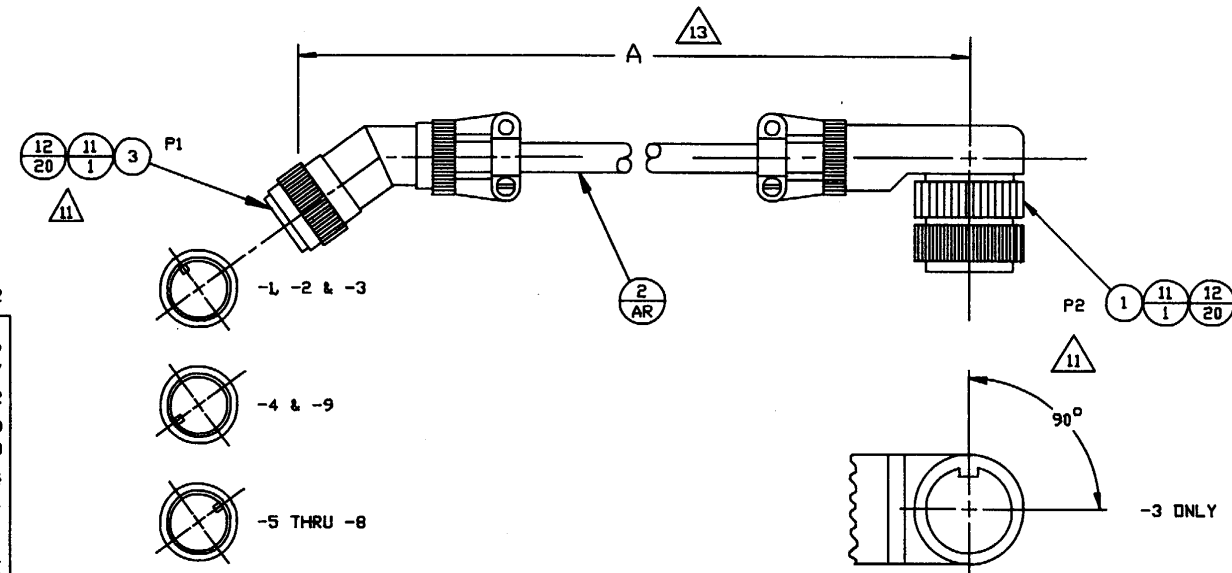
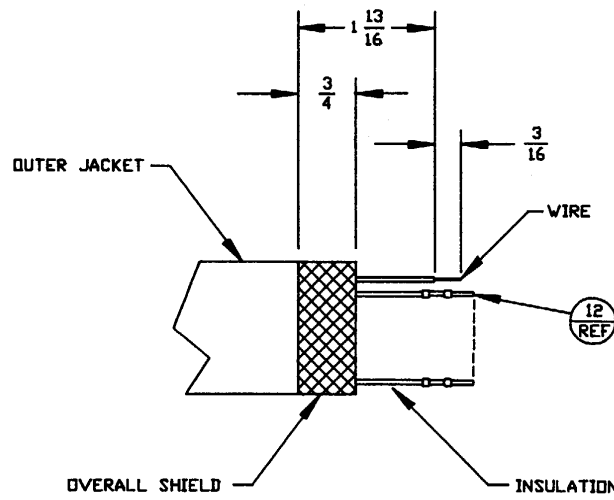
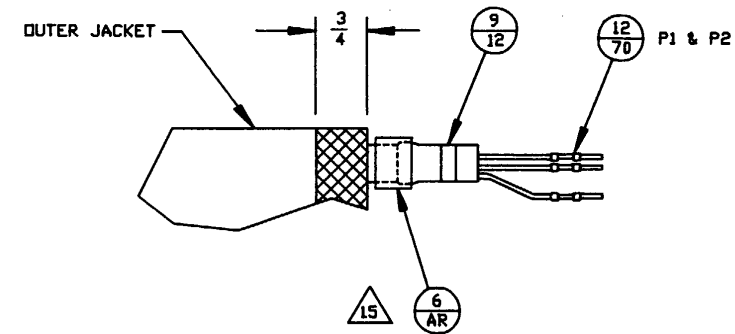

CHART A	
DASH NO.	DIMENSION A
1	97.00
2	110.00
3	293.00
4	364.00
5	282.00
6	75.00
7	352.00
8	182.00
9	182.00



△14 CABLE PREPARATION

SCALE : 2/1
BOTH ENDS



NOTES :

1. IDENTIFY PART PER MIL-STD-130, TAG.
 2. WORKMANSHIP SHALL BE IN ACCORDANCE WITH MIL-STD-454, REQUIREMENT 9.
 3. DIMENSIONAL DATA IS BASED ON AMERICAN NATIONAL STANDARD ANSI Y14.5-1973.
 4. CRIMPING INSERTION TOOL NO. M81969/14-01, REMOVAL TOOL NO. M81969/14-01, PER MIL-I-81969.
 5. CRIMPING TOOL NO. M22520/2-01 WITH M22520/2-07 TURRET, PER MIL-C-22520.
 6. EACH CONDUCTOR SHALL BE TESTED FOR CONTINUITY AND CORRECT CONNECTIONS BETWEEN ITS TERMINATIONS, USING A POTENTIAL OF NOT MORE THAN 10 VOLTS. CONTINUITY CHECKS SHALL BE MADE FROM CONNECTOR CONTACT TO CONNECTOR CONTACT USING A CONTINUITY TESTER. CONTINUITY POINTS SHALL BE OBTAINED FROM THE CABLE WIRING DIAGRAM. WHERE SHIELD IS BONDED TO CONNECTOR ON BOTH ENDS, THE SHIELD CONTINUITY SHALL BE CHECKED FROM CONNECTOR SHELL TO CONNECTOR SHELL.
 7. INSULATION RESISTANCE SHALL BE IN ACCORDANCE WITH METHOD 302 OF MIL-STD-202, TEST CONDITION B. THE POTENTIAL SHALL BE APPLIED BETWEEN EACH CONDUCTOR AND THE REMAINING CONDUCTORS CONNECTED TOGETHER AND TO THE SHIELD, AND CONNECTOR. THE INSULATION RESISTANCE OF THE CABLE ASSEMBLY SHALL NOT BE LESS THAN 100 MEGOHMS. EXCEPT THE INSULATION RESISTANCE OF A SHIELDED CONDUCTOR SHALL NOT BE LESS THAN 30 MEGOHMS.
 8. DIELECTRIC WITHSTANDING VOLTAGE. DIELECTRIC STRENGTH SHALL BE PERFORMED IN ACCORDANCE WITH METHOD 301 OF MIL-STD-202. A POTENTIAL OF 500 VOLTS DC SHALL BE APPLIED FOR 30 SECONDS MINIMUM. THE POTENTIAL SHALL BE APPLIED BETWEEN EACH CONDUCTOR AND THE REMAINING CONDUCTORS CONNECTED TOGETHER AND TO THE SHIELD AND CONNECTOR.
 9. PARTIAL REFERENCE DESIGNATIONS ARE SHOWN. FOR COMPLETE REFERENCE DESIGNATION, PREFIX WITH UNIT NUMBER AND SUBASSEMBLY DESIGNATION.
 10. SOLDERING SHALL BE IN ACCORDANCE WITH MIL-STD-454, REQUIREMENT 5.
- ⚠ ALL UNUSED POSITIONS IN CONNECTOR P1 AND P2 ARE TO BE FILLED WITH CONTACTS.
12. QUANTITY SHOWN IS IN INCHES.
- ⚠ TOLERANCE ON CABLE LENGTH SHALL BE +2, -1 INCHES.

- ⚠ 14. DIMENSIONS B (RANGE 1/4 TO 1/2) AND DIMENSION C (RANGE 1/2 TO 3/4) CAN INCREASE OR DECREASE PROPORTIONALLY TO ALLOW SOLDER FERRULE PLACEMENT TO BE VARIED.
- ⚠ 15. WHEN BACKSHELL'S DIA IS TOO SMALL TO CONTAIN INDIVIDUAL FERRULES IT IS PERMISSIBLE TO TERMINATE 2 SHIELDED WIRES IN THE SAME FERRULE.
- ⚠ 16. ALL SHIELDS MUST TERMINATE INSIDE OF EMI BACKSHELL.
- ⚠ 17. DIMENSIONS SHOWN ON CABLE PREPARATION ILLUSTRATION ARE FOR REFERENCE ONLY.
- ⚠ 18. PLACE HEAT SHRINK SLEEVING, ITEM 5, UNDER SOLDER FERRULE TO PROTECT WIRE.
19. VENDOR ITEM, SEE SPECIFICATION CONTROL DRAWING.
20. COMPLETE PART NUMBER FOR THIS ASSEMBLY SHALL INCLUDE APPLICABLE DASH NUMBER INDICATED IN QUANTITY REQUIRED COLUMN.

1	1	14	96906	MS27467T17B35S	CONNECTOR, ELECTRICAL, PLUG			
20	20	13	81349	M83519-1-2	FERRULE, SOLDER	MIL-S-83519		
121	121	12	81349	M39029/56-348	CRIMP CONTACTS, SOCKET	MIL-C-39029/56		
24	24	11	81349	M16878/4BEB9	WIRE, ELECTRICAL 24 AWG, WHITE	MIL-W-16878/4		12
1	1	10	81349	D38999/26WF35SN	CONNECTOR, ELECTRICAL, PLUG	MIL-C-38999/26		
		9						
		8						
		7						
		6						
13	13	5	81349	M23053/5-104-0	HEAT SHRINK SLEEVING	MIL-I-23053/5		12
REF	REF	4	80063	A3092728	TEST PROCEDURE/DATA SHEET POWER AND SIGNAL CABLE TEST			
1	1	3	80063	A3093589-20	BACKSHELL, EMI/RFI			19
1	1	2	80063	A3093589-19	BACKSHELL, EMI/RFI			19
445	494	1	80063	A3093588	CABLE, ELECTRICAL, SPECIAL PURPOSE			12 , 19
QTY REQD	QTY REQD	FIND NO.	FSCM NO.	PART NUMBER OR IDENTIFYING NO.	NOMENCLATURE OR DESCRIPTION	SPEC/STD	SHEET NO.	NOTE
-2	-1				PARTS LIST			

A3093621

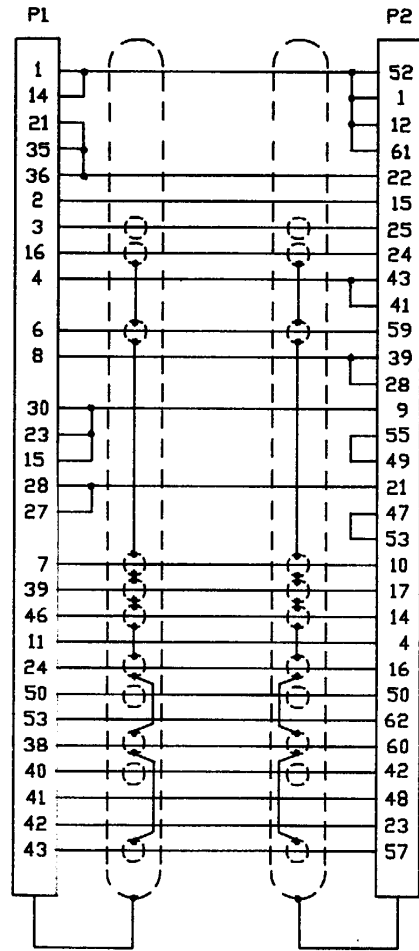

WIRING DIAGRAM

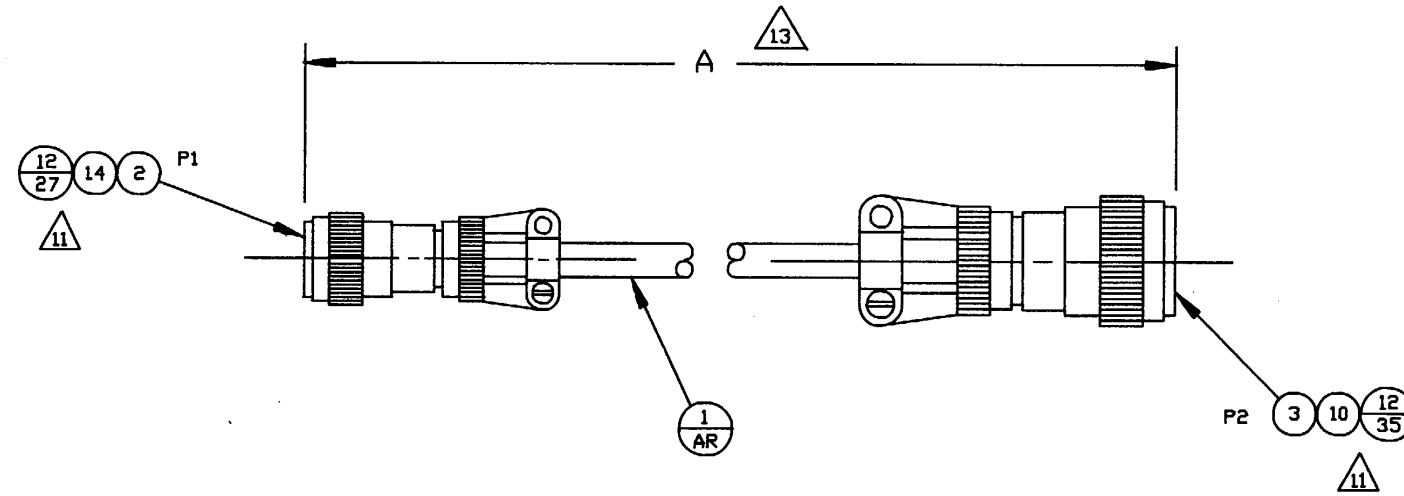
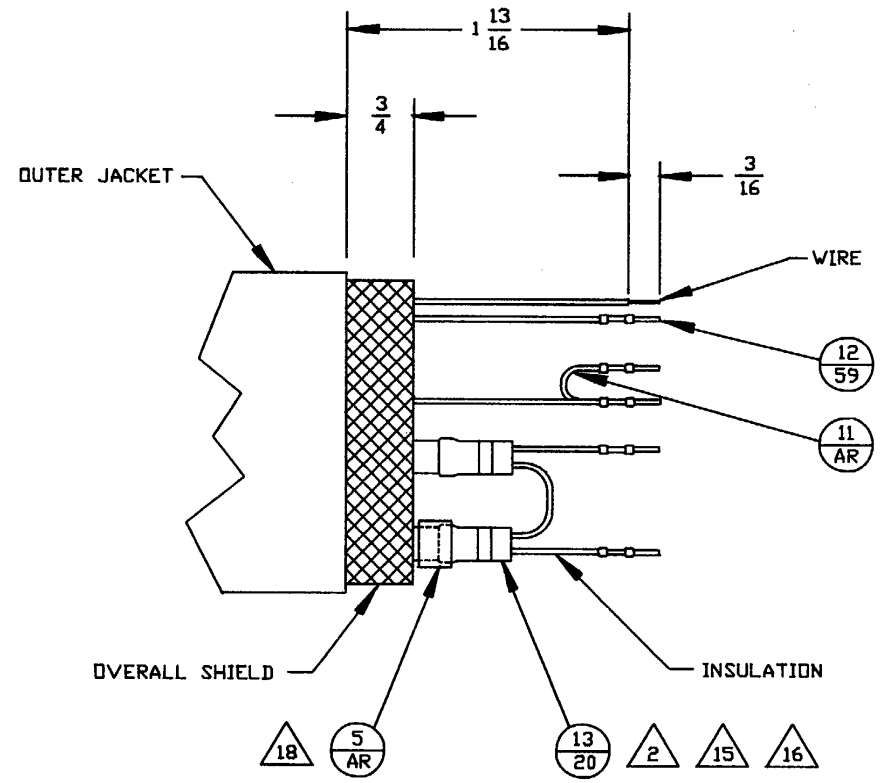
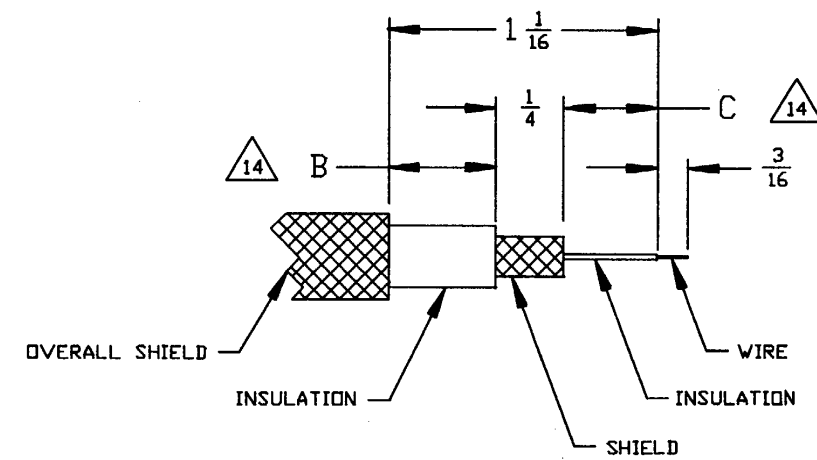

CHART A	
DASH NO.	DIMENSION A
1	494.00
2	445.00



17 CABLE PREPARATION

BOTH ENDS





17 CABLE PREPARATION

SCALE : 2/1
BOTH ENDS

NOTES :

1. IDENTIFY PART PER MIL-STD-130, TAG.
2. WORKMANSHIP SHALL BE IN ACCORDANCE WITH MIL-STD-454, REQUIREMENT 9.
3. DIMENSIONAL DATA IS BASED ON AMERICAN NATIONAL STANDARD ANSI Y14.5-1973.
4. COAXIAL CONTACT INSERTION TOOL NO. M81969/8-07, REMOVAL TOOL NO. M81969/8-08, CONTACT INSERTION / REMOVAL TOOL NO. M81969/14-01, PER MIL-I-81969.
5. CRIMP TOOL FOR COAXIAL CONTACTS ; INNER CONTACT M22520/2-01, POSITIONER M22520/2-35, FERRULE NO. M22520/4-01, POSITIONER NO. 22520/4-02, CONTACT CRIMP TOOL NO. M22520/2-01, TURRET NO. M22520/2-07, PER MIL-C-22520.
6. EACH CONDUCTOR SHALL BE TESTED FOR CONTINUITY AND CORRECT CONNECTIONS BETWEEN ITS TERMINATIONS, USING A POTENTIAL OF NOT MORE THAN 10 VOLTS. CONTINUITY CHECKS SHALL BE MADE FROM CONNECTOR CONTACT TO CONNECTOR CONTACT USING A CONTINUITY TESTER. CONTINUITY POINTS SHALL BE OBTAINED FROM THE CABLE WIRING DIAGRAM. WHERE SHIELD IS BONDED TO CONNECTOR ON BOTH ENDS, THE SHIELD CONTINUITY SHALL BE CHECKED FROM CONNECTOR SHELL TO CONNECTOR SHELL.
7. INSULATION RESISTANCE SHALL BE IN ACCORDANCE WITH METHOD 302 OF MIL-STD-202, TEST CONDITION B. THE POTENTIAL SHALL BE APPLIED BETWEEN EACH CONDUCTOR AND THE REMAINING CONDUCTORS CONNECTED TOGETHER AND TO THE SHIELD, AND CONNECTOR. THE INSULATION RESISTANCE OF THE CABLE ASSEMBLY SHALL NOT BE LESS THAN 100 MEGOHMS. EXCEPT THE INSULATION RESISTANCE OF A SHIELDED CONDUCTOR SHALL NOT BE LESS THAN 30 MEGOHMS.
8. DIELECTRIC WITHSTANDING VOLTAGE. DIELECTRIC STRENGTH SHALL BE PERFORMED IN ACCORDANCE WITH METHOD 301 OF MIL-STD-202. A POTENTIAL OF 500 VOLTS DC SHALL BE APPLIED FOR 30 SECONDS MINIMUM. THE POTENTIAL SHALL BE APPLIED BETWEEN EACH CONDUCTOR AND THE REMAINING CONDUCTORS CONNECTED TOGETHER AND TO THE SHIELD AND CONNECTOR.
9. PARTIAL REFERENCE DESIGNATIONS ARE SHOWN. FOR COMPLETE REFERENCE DESIGNATION, PREFIX WITH UNIT NUMBER AND SUBASSEMBLY DESIGNATION.

 FILL UNUSED POSITION (PIN C) IN CONNECTOR P1 WITH ITEM 11.

11. DELETED
12. QUANTITY SHOWN IS IN INCHES.
-  TOLERANCE ON CABLE LENGTH SHALL BE +2, -1 INCHES.
-  DIMENSIONS SHOWN ON CABLE PREPARATION ILLUSTRATION ARE FOR REFERENCE ONLY.
15. VENDOR ITEM, SEE SPECIFICATION CONTROL DRAWING.

1	15	96906	MS27467T9B44S	CONNECTOR, ELECTRICAL, PLUG			
1	14	96906	MS27473T12B3S	CONNECTOR, ELECTRICAL, PLUG			
2	13	81349	M39029/78/432	CONTACT, CRIMP, SOCKET	MIL-C-39029/77		
4	12	81349	M39029/57-350	CONTACT, CRIMP, SOCKET	MIL-C-39029/56		
1	11	81349	M39029/57-358	CONTACT, CRIMP, SOCKET	MIL-C-39029/57		
	10						
	9						
	8						
	7						
	6						
REF	5	80063	A3092728	TEST PROCEDURE/DATA SHEET POWER AND SIGNAL CABLE TEST			
2	4	80063	A3093560-1	SOLDER SLEEVE			15
192	3	80063	A3093559	CABLE, ELECTRICAL, SPECIAL PURPOSE			12 , 15
1	2	80063	A3093589-70	BACKSHELL, EMI/RFI			15
1	1	80063	A3092983-3	BACKSHELL, EMI/RFI			15
QTY REQD	FIND NO.	FSCM NO.	PART NUMBER OR IDENTIFYING NO.	NOMENCLATURE OR DESCRIPTION	SPEC/STD	SHEET NO.	NOTE
PARTS LIST							

A3093622

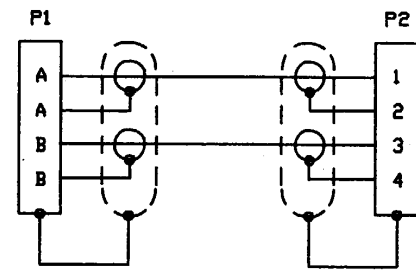

WIRING DIAGRAM

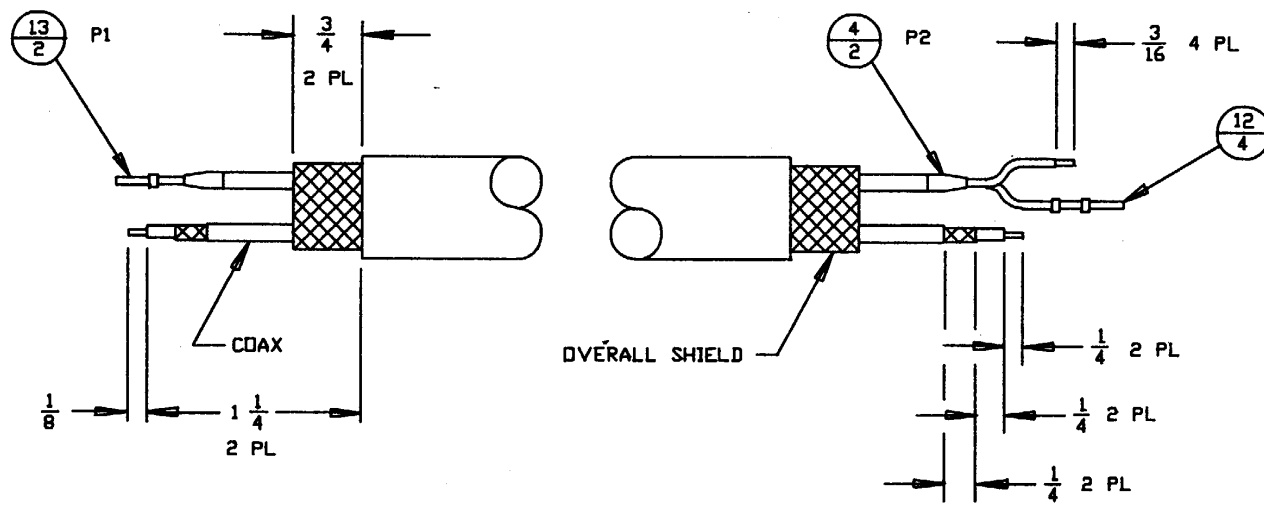
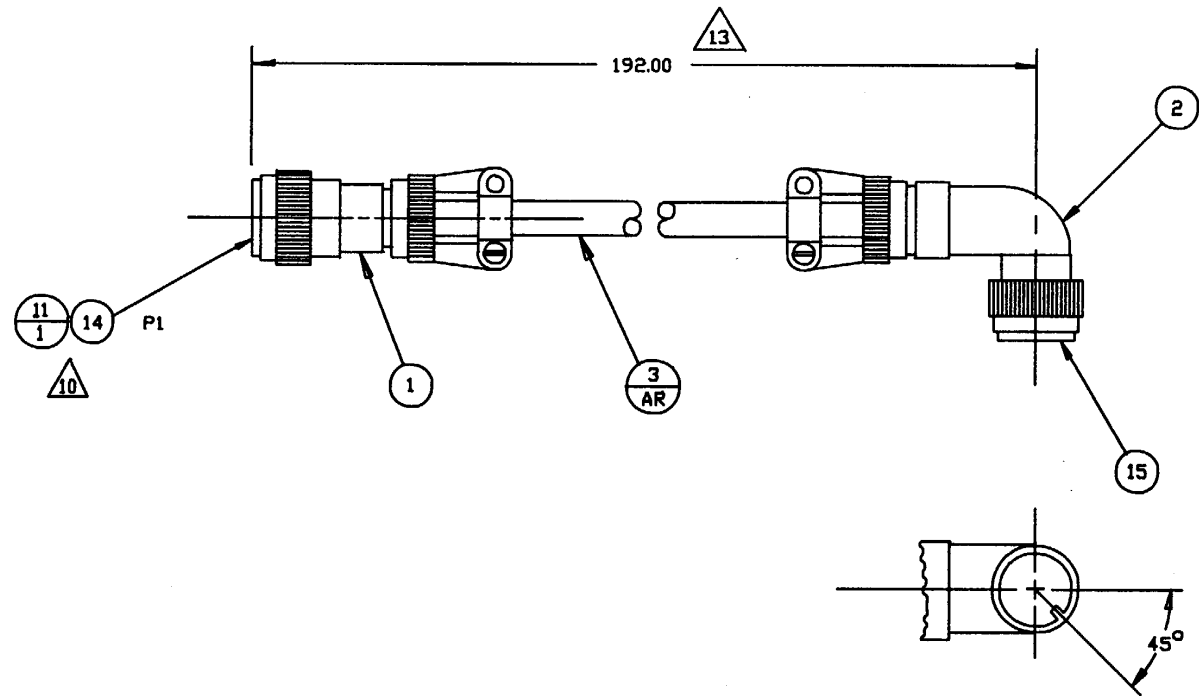

14 CABLE PREPARATION

SCALE : 2/1

A3093622

NOTES :

1. IDENTIFY PART PER MIL-STD-130, TAG.
2. WORKMANSHIP SHALL BE IN ACCORDANCE WITH MIL-STD-454, REQUIREMENT 9.
3. DIMENSIONAL DATA IS BASED ON AMERICAN NATIONAL STANDARD ANSI Y14.5-1973.
4. CRIMPING INSERTION TOOL NO. M81969/17-03, REMOVAL TOOL NO. M8969/19-07, PER MIL-I-81969.
5. CRIMPING TOOL NO. M22520/1-01 WITH M22520/1-02 TURRET, PER MIL-C-22520.
6. EACH CONDUCTOR SHALL BE TESTED FOR CONTINUITY AND CORRECT CONNECTIONS BETWEEN ITS TERMINATIONS, USING A POTENTIAL OF NOT MORE THAN 10 VOLTS. CONTINUITY CHECKS SHALL BE MADE FROM CONNECTOR CONTACT TO CONNECTOR CONTACT USING A CONTINUITY TESTER. CONTINUITY POINTS SHALL BE OBTAINED FROM THE CABLE WIRING DIAGRAM. WHERE SHIELD IS BONDED TO CONNECTOR ON BOTH ENDS, THE SHIELD CONTINUITY SHALL BE CHECKED FROM CONNECTOR SHELL TO CONNECTOR SHELL.
7. INSULATION RESISTANCE SHALL BE IN ACCORDANCE WITH METHOD 302 OF MIL-STD-202, TEST CONDITION B. THE POTENTIAL SHALL BE APPLIED BETWEEN EACH CONDUCTOR AND THE REMAINING CONDUCTORS CONNECTED TOGETHER AND TO THE SHIELD, AND CONNECTOR. THE INSULATION RESISTANCE OF THE CABLE ASSEMBLY SHALL NOT BE LESS THAN 100 MEGOHMS. EXCEPT THE INSULATION RESISTANCE OF A SHIELDED CONDUCTOR SHALL NOT BE LESS THAN 30 MEGOHMS.
8. DIELECTRIC WITHSTANDING VOLTAGE. DIELECTRIC STRENGTH SHALL BE PERFORMED IN ACCORDANCE WITH METHOD 301 OF MIL-STD-202. A POTENTIAL OF 500 VOLTS DC SHALL BE APPLIED FOR 30 SECONDS MINIMUM. THE POTENTIAL SHALL BE APPLIED BETWEEN EACH CONDUCTOR AND THE REMAINING CONDUCTORS CONNECTED TOGETHER AND TO THE SHIELD AND CONNECTOR.
9. PARTIAL REFERENCE DESIGNATIONS ARE SHOWN. FOR COMPLETE REFERENCE DESIGNATION, PREFIX WITH UNIT NUMBER AND SUBASSEMBLY DESIGNATION.
10. SOLDERING SHALL BE IN ACCORDANCE WITH MIL-STD-454, REQUIREMENT 5.

11. DIMENSIONS B (RANGE 1/4 TO 1/2) AND DIMENSION C (RANGE 1/2 TO 3/4) CAN INCREASE OR DECREASE PROPORTIONALLY TO ALLOW SOLDER FERRULE PLACEMENT TO BE VARIED.
12. INSTALL FERRULES ON SHIELDED TWISTED PAIRS AND SINGLE SHIELDED WIRE STARTING AT 1/2 INCH FROM END OF CONNECTOR AND 3/4 INCH SO FERRULES WILL NOT TERMINATE AT THE SAME LOCATION.
13. WHEN BACKSHELL'S DIA IS TOO SMALL TO CONTAIN INDIVIDUAL FERRULES IT IS PERMISSIBLE TO TERMINATE 2 SHIELDED WIRES IN THE SAME FERRULE.
14. ALL SHIELDS MUST TERMINATE INSIDE OF EMI BACKSHELL.
15. ALL UNUSED POSITIONS IN CONNECTOR P2 ARE TO BE FILLED WITH CONTACTS.
16. COMPLETE PART NUMBER FOR THIS ASSEMBLY SHALL INCLUDE APPLICABLE DASH NUMBER INDICATED IN QUANTITY REQUIRED COLUMN.
17. QUANTITY SHOWN IS IN INCHES.
18. TOLERANCE ON CABLE LENGTH SHALL BE +2, -1 INCHES.

NOTES CONTINUED ON SHEET 2

2	2	12	80063	A3093335-1 A3093335-1	FERRULE, SOLDER	MIL-S-83519	21	
6	6	11	81349	M39029/32-259 M39029/32-259	CONTACT, CRIMP, SOCKET	MIL-C-39029/32		
1	1	10	96906	MS3126F10-6S MS3126F10-6S	CONNECTOR, ELECTRICAL, PLUG			
2	2	9	81349	M16878/4BFEO M16878/4BFEO	WIRE, 22 AWG, BLACK	MIL-W-16878/4	17	
1	1	8	96906	MS3116F8-4P MS3116F8-4P	CONNECTOR, ELECTRICAL, PLUG			
2	2	7	81349	M23053/5-104-0 M23053/5-104-0	HEAT SHRINK SLEEVING	MIL-I-23053/5	17	
		6						
REF	REF	5	80063	A3092728 A3092728	TEST PROCEDURE/DATA SHEET POWER AND SIGNAL CABLE TEST			
		4						
1	1	3	80063	A3092984-2 A3092984-2	BACKSHELL, EMI/RFI		21	
1	1	2	80063	A3093589-64 A3093589-64	BACKSHELL, EMI/RFI		21	
90	531	1	80063	A3093563-2 A3093563-2	CABLE, RADIO FREQUENCY		17, 21	
QTY REQD	QTY REQD	FIND NO.	FSCM NO.	UNIT NUMBER OR IDENTIFYING NO.	NOMENCLATURE OR DESCRIPTION	SPEC/STD	SHEET NO.	NOTE
-2	-1				PARTS LIST			

A3093623

Cable Assembly, Patch/Radio (Sheet 1 of 2)

NOTES : CONTINUED FROM SHEET 1

- △19 DIMENSIONS SHOWN ON CABLE PREPARATION ILLUSTRATION ARE FOR REFERENCE ONLY.
- △20 PLACE HEAT SHRINK SLEEVING, ITEM 7, UNDER SOLDER FERRULE TO PROTECT WIRE.
- 21. VENDOR ITEM, SEE SPECIFICATION CONTROL DRAWING.
- △22 J HOOK SHIELDS TOGETHER. PLACE HEAT SHRINK SLEEVING, ITEM 7, OVER J HOOKS.
- △23 DAISY-CHAIN INNER SHIELDS TOGETHER USING FIND NOS. 9 AND 12. J-HOOK AND SOLDER TACK END OF CHAIN TO OUTER SHIELD.

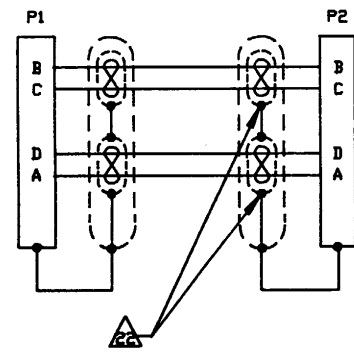

WIRING DIAGRAM

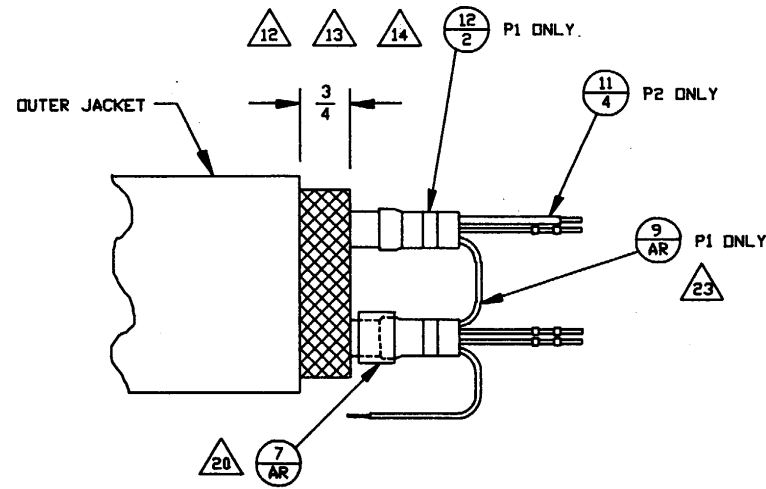
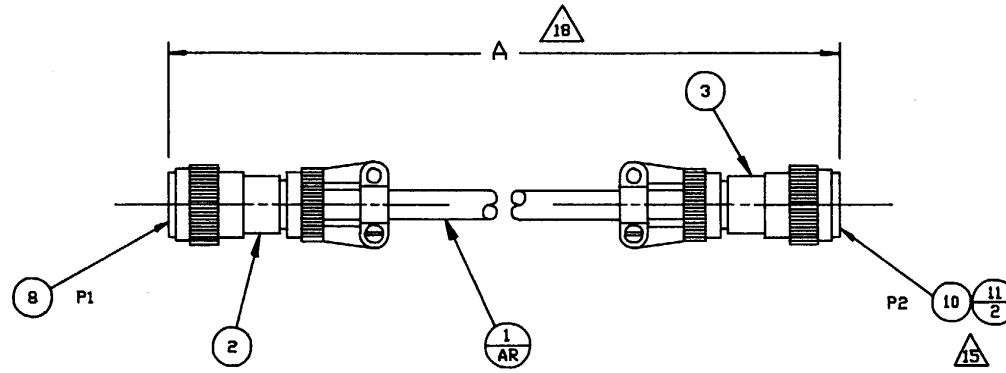
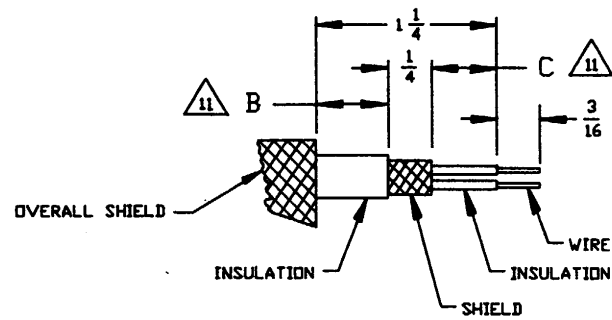

CHART	
DASH NO.	DIMENSION A
1	531.00
2	90.00



△19 CABLE PREPARATION

BOTH ENDS

A3093623

NOTES :

1. IDENTIFY PART PER MIL-STD-130, TAG.
 2. WORKMANSHIP SHALL BE IN ACCORDANCE WITH MIL-STD-454, REQUIREMENT 9.
 3. DIMENSIONAL DATA IS BASED ON AMERICAN NATIONAL STANDARD ANSI Y14.5-1973.
 4. CRIMP INSERTION AND REMOVAL TOOL NO. M81969/1-02.
 5. CRIMPING TOOL FOR P1 AND P2 M22520/2-01, WITH M22520-08 TURRET.
 6. EACH CONDUCTOR SHALL BE TESTED FOR CONTINUITY AND CORRECT CONNECTIONS BETWEEN ITS TERMINATIONS, USING A POTENTIAL OF NOT MORE THAN 10 VOLTS. CONTINUITY CHECKS SHALL BE MADE FROM CONNECTOR CONTACT TO CONNECTOR CONTACT USING A CONTINUITY TESTER. CONTINUITY POINTS SHALL BE OBTAINED FROM THE CABLE WIRING DIAGRAM. WHERE SHIELD IS BONDED TO CONNECTOR ON BOTH ENDS, THE SHIELD CONTINUITY SHALL BE CHECKED FROM CONNECTOR SHELL TO CONNECTOR SHELL.
 7. INSULATION RESISTANCE SHALL BE IN ACCORDANCE WITH METHOD 302 OF MIL-STD-202, TEST CONDITION B. THE POTENTIAL SHALL BE APPLIED BETWEEN EACH CONDUCTOR AND THE REMAINING CONDUCTORS CONNECTED TOGETHER AND TO THE SHIELD, AND CONNECTOR. THE INSULATION RESISTANCE OF THE CABLE ASSEMBLY SHALL NOT BE LESS THAN 100 MEGOHMS, EXCEPT THE INSULATION RESISTANCE OF A SHIELDED CONDUCTOR SHALL NOT BE LESS THAN 30 MEGOHMS.
 8. DIELECTRIC WITHSTANDING VOLTAGE. DIELECTRIC STRENGTH SHALL BE PERFORMED IN ACCORDANCE WITH METHOD 301 OF MIL-STD-202. A POTENTIAL OF 500 VOLTS DC SHALL BE APPLIED FOR 30 SECONDS MINIMUM. THE POTENTIAL SHALL BE APPLIED BETWEEN EACH CONDUCTOR AND THE REMAINING CONDUCTORS CONNECTED TOGETHER AND TO THE SHIELD AND CONNECTOR.
 9. PARTIAL REFERENCE DESIGNATIONS ARE SHOWN. FOR COMPLETE REFERENCE DESIGNATION, PREFIX WITH UNIT NUMBER AND SUBASSEMBLY DESIGNATION.
- ⚠ ALL UNUSED POSITIONS IN CONNECTORS P1 & P2 ARE TO BE FILLED WITH CONTACTS.
11. QUANTITY SHOWN IS IN INCHES.
 - ⚠ TOLERANCE ON CABLE LENGTH SHALL BE +.5,-0 INCHES.
 13. VENDOR ITEM-SEE SPECIFICATION CONTROL DRAWING.
 14. FIND NO. 7 CONSISTS OF 2 POSTS, 4 FLAT WASHERS, 2 LOCK WASHERS AND 2 HEX NUTS PER PART NUMBER.
 15. FIND NO. 8 CONSISTS OF 2 CLIPS, 2 SCREWS, 2 FLAT WASHERS, 2 LOCK WASHERS AND 2 HEX NUTS PER PART NUMBER.

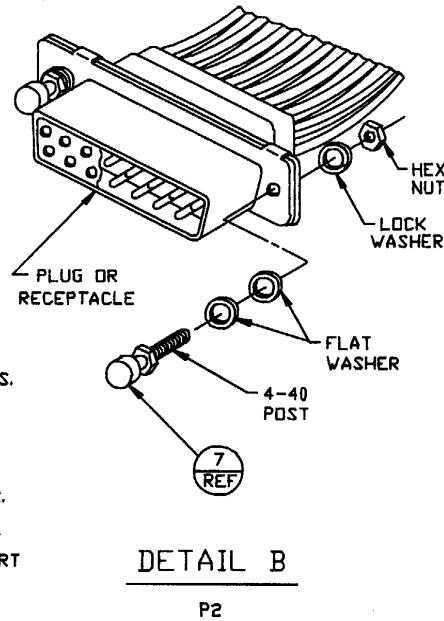
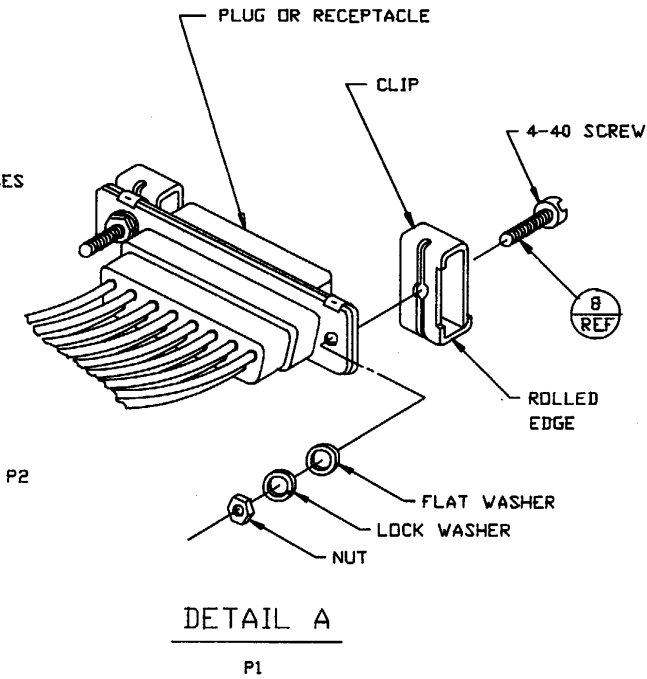
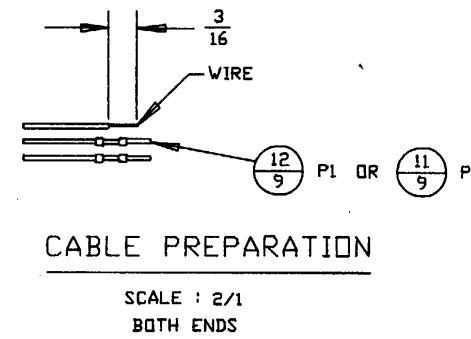
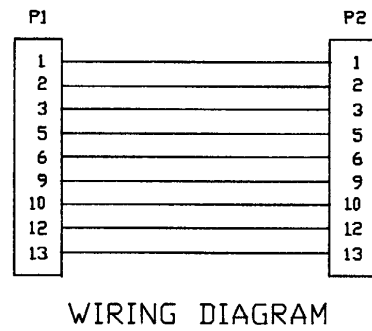
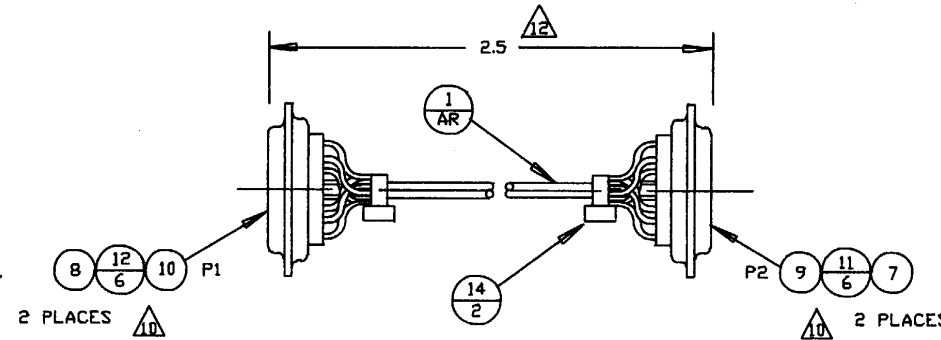

2	14	96906	MS3367-1-9	STRAP, TIE DOWN, ELECTRICAL			
	13						
15	12	81349	M39029/64-369	CONTACT, CRIMP, PIN	MIL-C-39029/64		
15	11	81349	M39029/63-368	CONTACT, CRIMP, SOCKET	MIL-C-39029/63		
1	10	81349	M24308/4-2	CONNECTOR, ELECTRICAL, PLUG	MIL-C-24308/4		
1	9	81349	M24308/2-2	CONNECTOR, ELECTRICAL, SOCKET	MIL-C-24308/2		
1	8	80063	A3105761-2	SIDE LATCH CLIP			13 , 15
1	7	80063	A3105761-1	LOCKING POST			13 , 14
	6						
	5						
REF	4	80063	A3092728	TEST PROCEDURE/DATA SHEET POWER AND SIGNAL CABLE TEST			
	3						
	2						
27	1	81349	M16878/4BFB9	WIRE, ELECTRICAL	MIL-W-16878/4		11
QTY REQD	FIND NO.	FSCN NO.	PART NUMBER OR IDENTIFYING NO.	NOMENCLATURE OR DESCRIPTION	SPEC/STD	SHEET NO.	NOTE
PARTS LIST							

A3093625

Cable Assembly, FOER J3, Jumper

NOTES :

1. IDENTIFY PART PER MIL-STD-130, TAG.
2. WORKMANSHIP SHALL BE IN ACCORDANCE WITH MIL-STD-454, REQUIREMENT 9.
3. DIMENSIONAL DATA IS BASED ON AMERICAN NATIONAL STANDARD ANSI Y14.5-1973.
4. EACH CONDUCTOR SHALL BE TESTED FOR CONTINUITY AND CORRECT CONNECTIONS BETWEEN ITS TERMINATIONS, USING A POTENTIAL OF NOT MORE THAN 0 VOLTS. CONTINUITY CHECKS SHALL BE MADE FROM CONNECTOR CONTACT TO CONNECTOR CONTACT USING A CONTINUITY TESTER. CONTINUITY POINTS SHALL BE OBTAINED FROM THE CABLE WIRING DIAGRAM. WHERE SHIELD IS BONDED TO CONNECTOR ON BOTH ENDS, THE SHIELD CONTINUITY SHALL BE CHECKED FROM CONNECTOR SHELL TO CONNECTOR SHELL.
5. INSULATION RESISTANCE SHALL BE IN ACCORDANCE WITH METHOD 302 OF MIL-STD-202, TEST CONDITION B. THE POTENTIAL SHALL BE APPLIED BETWEEN EACH CONDUCTOR AND THE REMAINING CONDUCTORS CONNECTED TOGETHER AND TO THE SHIELD, AND CONNECTOR. THE INSULATION RESISTANCE OF THE CABLE ASSEMBLY SHALL NOT BE LESS THAN 100 MEGOHMS. EXCEPT THE INSULATION RESISTANCE OF A SHIELDED CONDUCTOR SHALL NOT BE LESS THAN 30 MEGOHMS.
6. DIELECTRIC WITHSTAND VOLTAGE. DIELECTRIC STRENGTH SHALL BE PERFORMED IN ACCORDANCE WITH METHOD 301 OF MIL-STD-202. A POTENTIAL OF 500 VOLTS DC SHALL BE APPLIED FOR 30 SECONDS MINIMUM. THE POTENTIAL SHALL BE APPLIED BETWEEN EACH CONDUCTOR AND THE REMAINING CONDUCTORS CONNECTED TOGETHER AND TO THE SHIELD AND CONNECTOR.
7. PARTIAL REFERENCE DESIGNATION ARE SHOWN. FOR COMPLETE REFERENCE DESIGNATION, PREFIX WITH UNIT NUMBER AND SUBASSEMBLY DESIGNATION.
8. SOLDERING SHALL BE IN ACCORDANCE WITH MIL-STD-454, REQUIREMENT 5.
9. QUANTITY SHOWN IS IN INCHES.
10. TOLERANCE ON CABLE LENGTH SHALL BE +2, -1 INCHES.
11. COMPLETE PART NUMBER FOR THE ASSEMBLY SHALL INCLUDE APPLICABLE DASH NUMBER INDICATED IN QUANTITY REQUIRED COLUMN.
12. DIMENSIONS SHOWN ON CABLE PREPARATION ILLUSTRATION ARE FOR REFERENCE ONLY.

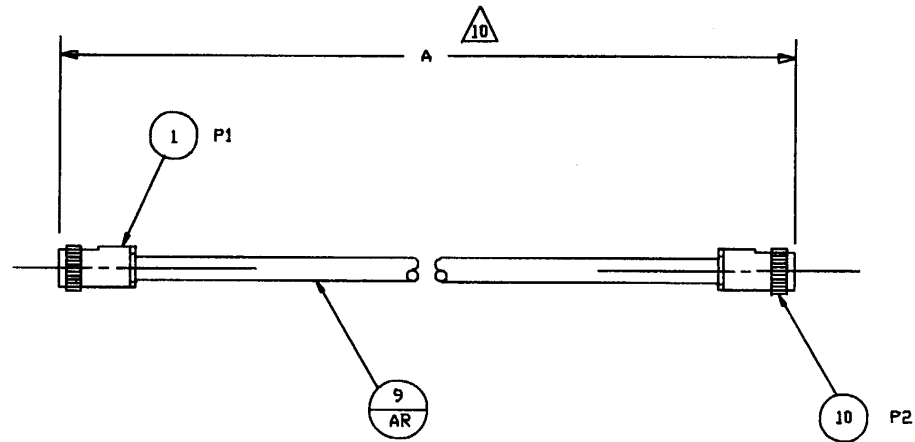
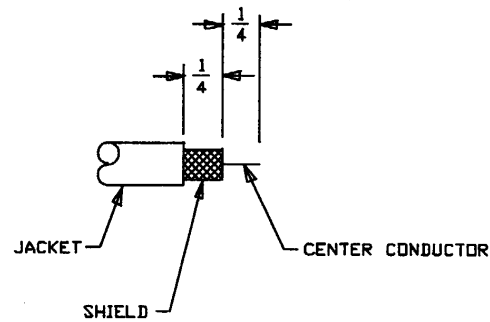

CHART	
DASH NO.	DIMENSION A
1	52.00
2	270.00
3	230.00



CABLE PREPARATION \triangle_{10} \triangle_{12}

SCALE : NONE
BOTH ENDS

1	1	1	10	80058	UG-959 A/U	CONNECTOR, RF			
230	270	52	9	81349	M1775-RG214	CABLE, RF	MIL-C-1775		9
			8						
			7						
			6						
			5						
REF	REF	REF	4	80063	A3092728	TEST PROCEDURE/DATA SHEET POWER AND SIGNAL CABLE TEST			
			3						
			2						
1	1	1	1	81349	M39012/01-005	CONNECTOR, RF	MIL-C-39012		
QTY REQD	QTY REQD	QTY RFQD	FIND NO.	FSCM NO.	PART NUMBER OR IDENTIFYING NO.	NOMENCLATURE OR DESCRIPTION	SPEC/STD	SHEET NO.	NOTE
-3	-2	-1				PARTS LIST			

A3093628

Cable Assembly, Radio/Antenna

NOTES :

1. IDENTIFY PART PER MIL-STD-130, TAG.
2. WORKMANSHIP SHALL BE IN ACCORDANCE WITH MIL-STD-454, REQUIREMENT 9.
3. DIMENSIONAL DATA IS BASED ON AMERICAN NATIONAL STANDARD ANSI Y14.5-1973.
4. CRIMP INSERTION TOOL NO. M81969/17-03, REMOVAL TOOL NO. M81969/19-07.
5. CRIMPING TOOL NO. M22520/1-01 WITH M22520/1-02 TURRET.
6. EACH CONDUCTOR SHALL BE TESTED FOR CONTINUITY AND CORRECT CONNECTIONS BETWEEN ITS TERMINATIONS, USING A POTENTIAL OF NOT MORE THAN 10 VOLTS. CONTINUITY CHECKS SHALL BE MADE FROM CONNECTOR CONTACT TO CONNECTOR CONTACT USING A CONTINUITY TESTER. CONTINUITY POINTS SHALL BE OBTAINED FROM THE CABLE WIRING DIAGRAM. WHERE SHIELD IS BONDED TO CONNECTOR ON BOTH ENDS, THE SHIELD CONTINUITY SHALL BE CHECKED FROM CONNECTOR SHELL TO CONNECTOR SHELL.
7. INSULATION RESISTANCE SHALL BE IN ACCORDANCE WITH METHOD 302 OF MIL-STD-202, TEST CONDITION B. THE POTENTIAL SHALL BE APPLIED BETWEEN EACH CONDUCTOR AND THE REMAINING CONDUCTORS CONNECTED TOGETHER AND TO THE SHIELD, AND CONNECTOR. THE INSULATION RESISTANCE OF THE CABLE ASSEMBLY SHALL NOT BE LESS THAN 100 MEGOHMS. EXCEPT THE INSULATION RESISTANCE OF A SHIELDED CONDUCTOR SHALL NOT BE LESS THAN 30 MEGOHMS.
8. DIELECTRIC WITHSTANDING VOLTAGE. DIELECTRIC STRENGTH SHALL BE PERFORMED IN ACCORDANCE WITH METHOD 301 OF MIL-STD-202. A POTENTIAL OF 500 VOLTS DC SHALL BE APPLIED FOR 30 SECONDS MINIMUM. THE POTENTIAL SHALL BE APPLIED BETWEEN EACH CONDUCTOR AND THE REMAINING CONDUCTORS CONNECTED TOGETHER AND TO THE SHIELD AND CONNECTOR.
9. PARTIAL REFERENCE DESIGNATIONS ARE SHOWN. FOR COMPLETE REFERENCE DESIGNATION, PREFIX WITH UNIT NUMBER AND SUBASSEMBLY DESIGNATION.
10. SOLDERING SHALL BE IN ACCORDANCE WITH MIL-STD-454, REQUIREMENT 5.

- 11. DELETED.
- 12. DELETED.
- 13. DELETED.
- 14. ALL SHIELDS MUST TERMINATE INSIDE OF EMI BACKSHELL.
- 15. ALL UNUSED POSITIONS IN CONNECTOR P1 ARE TO BE FILLED WITH CONTACTS.
- 16. COMPLETE PART NUMBER FOR THIS ASSEMBLY SHALL INCLUDE APPLICABLE DASH NUMBER INDICATED IN QUANTITY REQUIRED COLUMN.
- 17. QUANTITY SHOWN IS IN INCHES.
- 18. TOLERANCE ON CABLE LENGTH SHALL BE +2, -1 INCHES.
- 19. DIMENSIONS SHOWN ON CABLE PREPARATION ILLUSTRATION ARE FOR REFERENCE ONLY.
- 20. DELETED.
- 21. VENDOR ITEM - SEE SPECIFICATION CONTROL DRAWING.

		12						
55	55	11	81349	M39029/32-259	CONTACT, CRIMP, SOCKET	MIL-C-39029/32		
1	1	10	96906	MS3126F22-55S	CONNECTOR, ELECTRICAL, PLUG			
1	1	9	96906	MS27467T23B53S	CONNECTOR, ELECTRICAL, PLUG			
		8						
		7						
		6						
REF	REF	5	80063	A3092728	TEST PROCEDURE/DATA SHEET POWER AND SIGNAL CABLE TEST			
53	53	4	81349	M39029/56-351	CONTACT, CRIMP, SOCKET	MIL-C-39029/56		
1	1	3	80063	A3093589-63	BACKSHELL, EMI/RFI			21
1	1	2	80063	A3092979-8	BACKSHELL, EMI/RFI			21
177	177	1	80063	A3093563-25	CABLE, ELECTRICAL, SPECIAL PURPOSE			17, 21
QTY REQD	QTY REQD	FIND NO.	FSCM NO.	PART NUMBER OR IDENTIFYING NO.	NOMENCLATURE OR DESCRIPTION	SPEC/STD	SHEET NO.	NOTE
-2	-1			PARTS LIST				

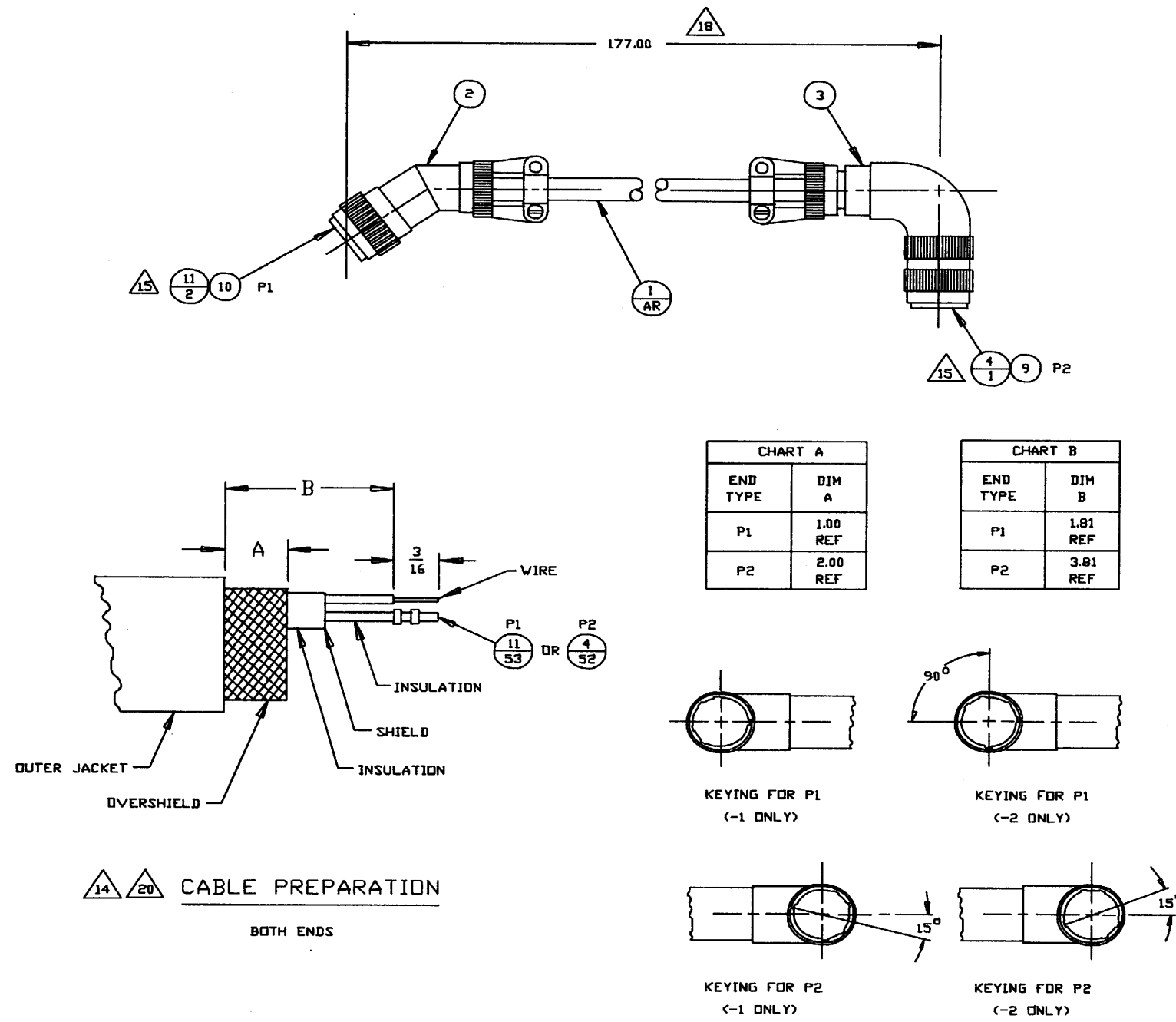
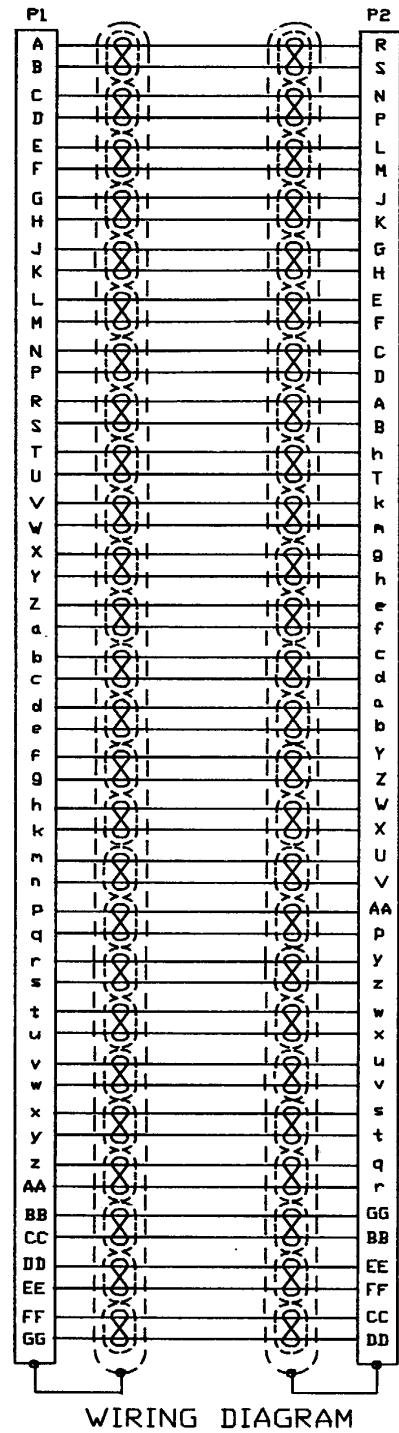

Cable Assembly, Patch/SEP (Sheet 2 of 2)

DASH NO.	NEXT ASSEMBLY	USED ON	QTY	DASH NO.	NEXT ASSEMBLY	USED ON	QTY
31	A3092661	DLA3092661	1	46	A3092661	DLA3092661	1
31	A3092811	DLA3092811	1	46	A3092811	DLA3092811	1
32	A3092661	DLA3092661	1	47	A3092661	DLA3092661	1
32	A3092811	DLA3092811	1	47	A3092811	DLA3092811	1
33	A3092661	DLA3092661	1	48	A3092661	DLA3092661	1
33	A3092811	DLA3092811	1	48	A3092811	DLA3092811	1
34	A3092661	DLA3092661	1	49	A3092661	DLA3092661	1
34	A3092811	DLA3092811	1	49	A3092811	DLA3092811	1
35	A3092661	DLA3092661	1	50	A3092661	DLA3092661	1
35	A3092811	DLA3092811	1	50	A3092811	DLA3092811	1
36	A3092661	DLA3092661	1	51	A3092661	DLA3092661	1
36	A3092811	DLA3092811	1	51	A3092811	DLA3092811	1
37	A3092661	DLA3092661	1	52	A3092661	DLA3092661	1
37	A3092811	DLA3092811	1	52	A3092811	DLA3092811	1
38	A3092661	DLA3092661	1	53	A3092661	DLA3092661	1
38	A3092811	DLA3092811	1	53	A3092811	DLA3092811	1
39	A3092661	DLA3092661	1	54	A3092661	DLA3092661	1
39	A3092811	DLA3092811	1	54	A3092811	DLA3092811	1
40	A3092661	DLA3092661	1	55	A3092661	DLA3092661	1
40	A3092811	DLA3092811	1	55	A3092811	DLA3092811	1
41	A3092661	DLA3092661	1	56	A3092661	DLA3092661	1
41	A3092811	DLA3092811	1	56	A3092811	DLA3092811	1
42	A3092661	DLA3092661	1	57	A3092661	DLA3092661	1
42	A3092811	DLA3092811	1	57	A3092811	DLA3092811	1
43	A3092661	DLA3092661	1	58	A3092661	DLA3092661	1
43	A3092811	DLA3092811	1	58	A3092811	DLA3092811	1
44	A3092661	DLA3092661	1	59	A3092661	DLA3092661	1
44	A3092811	DLA3092811	1	59	A3092811	DLA3092811	1
45	A3092661	DLA3092661	1	60	A3092661	DLA3092661	1
45	A3092811	DLA3092811	1	60	A3092811	DLA3092811	1

0307N	THIS DOCUMENT HAS BEEN PURCHASED BY THE GOVERNMENT AND MAY BE REPRODUCED AND USED IN CONNECTION WITH ANY GOVERNMENT PROCUREMENT OR MAINTENANCE OPERATION	SIZE	FSCM NO.	DRAWING NO.	
		A	80063	A3093630	
		SCALE	NONE	LTR	J SHEET 3

DASH NO.	NEXT ASSEMBLY	USED ON	QTY	DASH NO.	NEXT ASSEMBLY	USED ON	QTY
61	A3092661	DLA3092661	1	76	A3092661	DLA3092661	1
61	A3092811	DLA3092811	1	76	A3092811	DLA3092811	1
	A3092661	DLA3092661	1	77			
	A3092811	DLA3092811	1	77			
63	A3092661	DLA3092661	1	78	A3092661	DLA3092661	1
63	A3092811	DLA3092811	1	78	A3092811	DLA3092811	1
64	A3092661	DLA3092661	1	79	A3092661	DLA3092661	1
64	A3092811	DLA3092811	1	79	A3092811	DLA3092811	1
	A3092661	DLA3092661	1	80			
	A3092811	DLA3092811	1	80			
66	A3092661	DLA3092661	1	81	A3092661	DLA3092661	1
66	A3092811	DLA3092811	1	81	A3092811	DLA3092811	1
67	A3092661	DLA3092661	1	82	A3092661	DLA3092661	1
67	A3092811	DLA3092811	1	82	A3092811	DLA3092811	1
68	A3092661	DLA3092661	1	83	A3092661	DLA3092661	1
68	A3092811	DLA3092811	1	83	A3092811	DLA3092811	1
69	A3092661	DLA3092661	1	84	A3092661	DLA3092661	1
69	A3092811	DLA3092811	1	84	A3092811	DLA3092811	1
70	A3092661	DLA3092661	1	85	A3092661	DLA3092661	1
70	A3092811	DLA3092811	1	85	A3092811	DLA3092811	1
71	A3092661	DLA3092661	1	86	A3092661	DLA3092661	1
71	A3092811	DLA3092811	1	86	A3092811	DLA3092811	1
72	A3092661	DLA3092661	1	87	A3092661	DLA3092661	1
72	A3092811	DLA3092811	1	87	A3092811	DLA3092811	1
73	A3092661	DLA3092661	1	88	A3092661	DLA3092661	1
73	A3092811	DLA3092811	1	88	A3092811	DLA3092811	1
74	A3092661	DLA3092661	1	89	A3092661	DLA3092661	1
74	A3092811	DLA3092811	1	89	A3092811	DLA3092811	1
75	A3092661	DLA3092661	1	90	A3092661	DLA3092661	1
75	A3092811	DLA3092811	1	90	A3092811	DLA3092811	1

	THIS DOCUMENT HAS BEEN PURCHASED BY THE GOVERNMENT AND MAY BE REPRODUCED AND USED IN CONNECTION WITH ANY GOVERNMENT PROCUREMENT OR MAINTENANCE OPERATION	SIZE	FSCM NO.	DRAWING NO.	
		A	80063	A3093630	
		SCALE	NONE	LTR	J SHEET 4

DASH NO.	NEXT ASSEMBLY	USED ON	QTY	DASH NO.	NEXT ASSEMBLY	USED ON	QTY
92	A3092661	DLA3092661	1				
92	A3092811	DLA3092811	1				
93	A3092661	DLA3092661	1				
93	A3092811	DLA3092811	1				
94	A3092661	DLA3092661	1				
94	A3092811	DLA3092811	1				
95	A3092661	DLA3092661	1				
95	A3092811	DLA3092811	1				
96	A3092661	DLA3092661	1				
96	A3092811	DLA3092811	1				
97	A3092661	DLA3092661	1				
97	A3092811	DLA3092811	1				
99	A3092661	DLA3092661	1				
99	A3092811	DLA3092811	1				
100	A3092661	DLA3092661	1				
100	A3092811	DLA3092811	1				
101	A3092661	DLA3092661	1				
101	A3092811	DLA3092811	1				
102	A3092661	DLA3092661	1				
102	A3092811	DLA3092811	1				
103	A3092661	DLA3092661	1				
103	A3092811	DLA3092811	1				
104	A3092661	DLA3092661	1				
104	A3092811	DLA3092811	1				

0307N	THIS DOCUMENT HAS BEEN PURCHASED BY THE GOVERNMENT AND MAY BE REPRODUCED AND USED IN CONNECTION WITH ANY GOVERNMENT PROCUREMENT OR MAINTENANCE OPERATION	SIZE	FSCM NO.	DRAWING NO.	
		A	80063	A3093630	
		SCALE	NONE	LTR	J SHEET 5

NOTES:

1. PREPARED IN ACCORDANCE WITH DOD-STD-100.
2. UNLESS OTHERWISE SPECIFIED, DIMENSIONS ARE IN INCHES.
3. UNLESS OTHERWISE SPECIFIED, TOLERANCES ARE: 2 PLACE DECIMALS + .02, 3 PLACE DECIMALS. + .010, FRACTIONS + 1/32, ANGLES + 1 DEGREE, AND HOLE DIAMETERS + .
4. WORKMANSHIP SHALL BE IN ACCORDANCE WITH MIL-STD-454, REQUIREMENT 9.
5. DIMENSIONAL DATA IS BASED ON AMERICAN NATIONAL STANDARD ANSI Y14.5-1973.
6. A TYPE MARKING ON FIND NO. 1 OR 2. MARK PER A3092959, DECAL FABRICATION.
7. PARTIAL REFERENCE DESIGNATIONS ARE SHOWN. FOR COMPLETE REFERENCE DESIGNATION, PREFIX WITH UNIT NUMBER AND SUBASSEMBLY DESIGNATION.
8. CABLE MARKERS MAY BE APPLIED TO CABLES SUCH THAT MARKERS READ EITHER AWAY FROM CABLE END OR TOWARDS CABLE END.
9. CABLE MARKER LOCATION TOLERANCES SHALL BE + 2.00.

THIS DOCUMENT HAS BEEN PURCHASED BY THE GOVERNMENT AND MAY BE REPRODUCED AND USED IN CONNECTION WITH ANY GOVERNMENT PROCUREMENT OR MAINTENANCE OPERATION	SIZE	FSCM NO.	DRAWING NO.	
	A	80063	A3093630	
		SCALE	NONE	LTR J SHEET 6

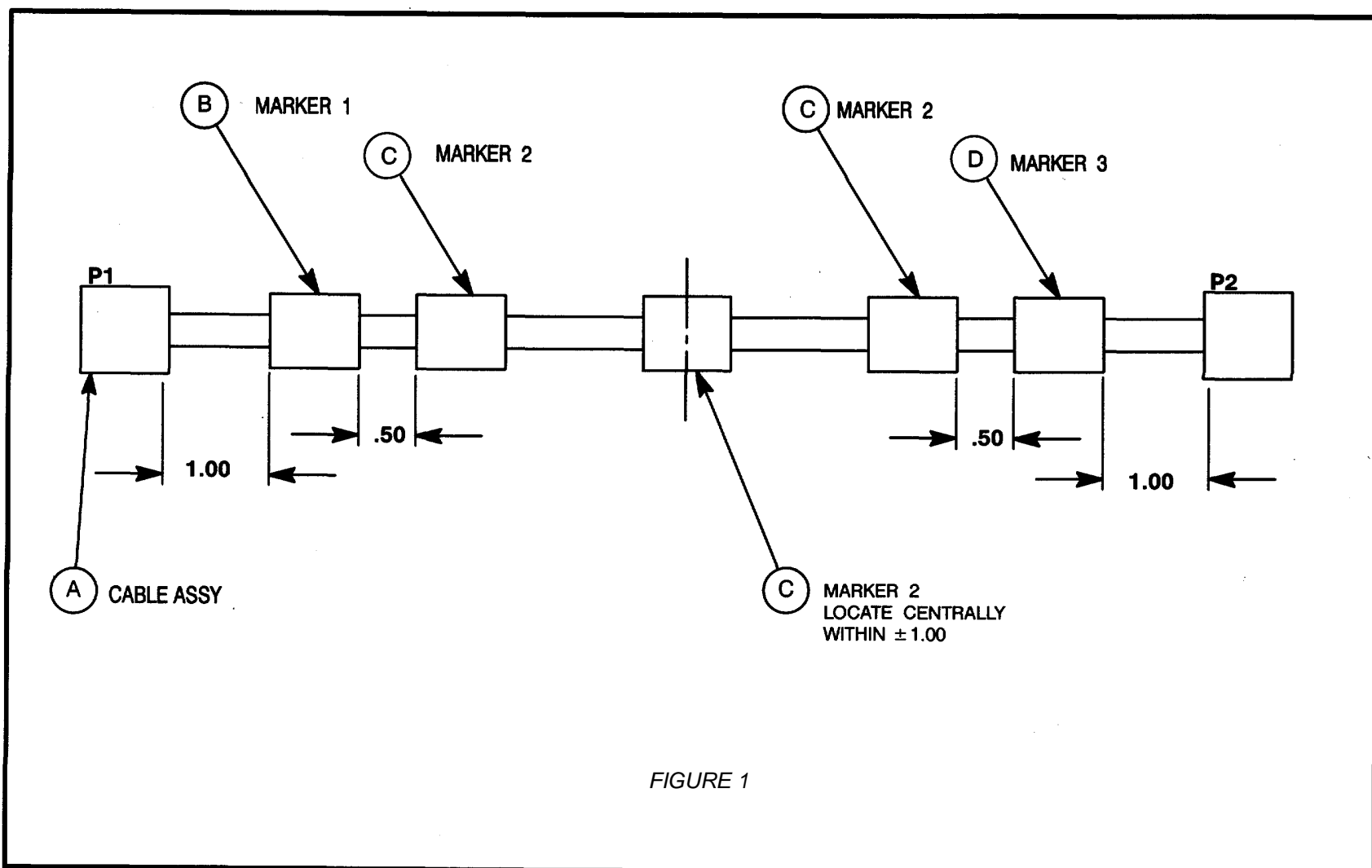

FIGURE 1

THIS DOCUMENT HAS BEEN PURCHASED BY THE GOVERNMENT AND MAY BE REPRODUCED AND USED IN CONNECTION WITH ANY GOVERNMENT PROCUREMENT OR MAINTENANCE OPERATION	SIZE	FSCM NO.	DRAWING NO.
	A	80063	A3093630
	SCALE	NONE	LTR A SHEET 7

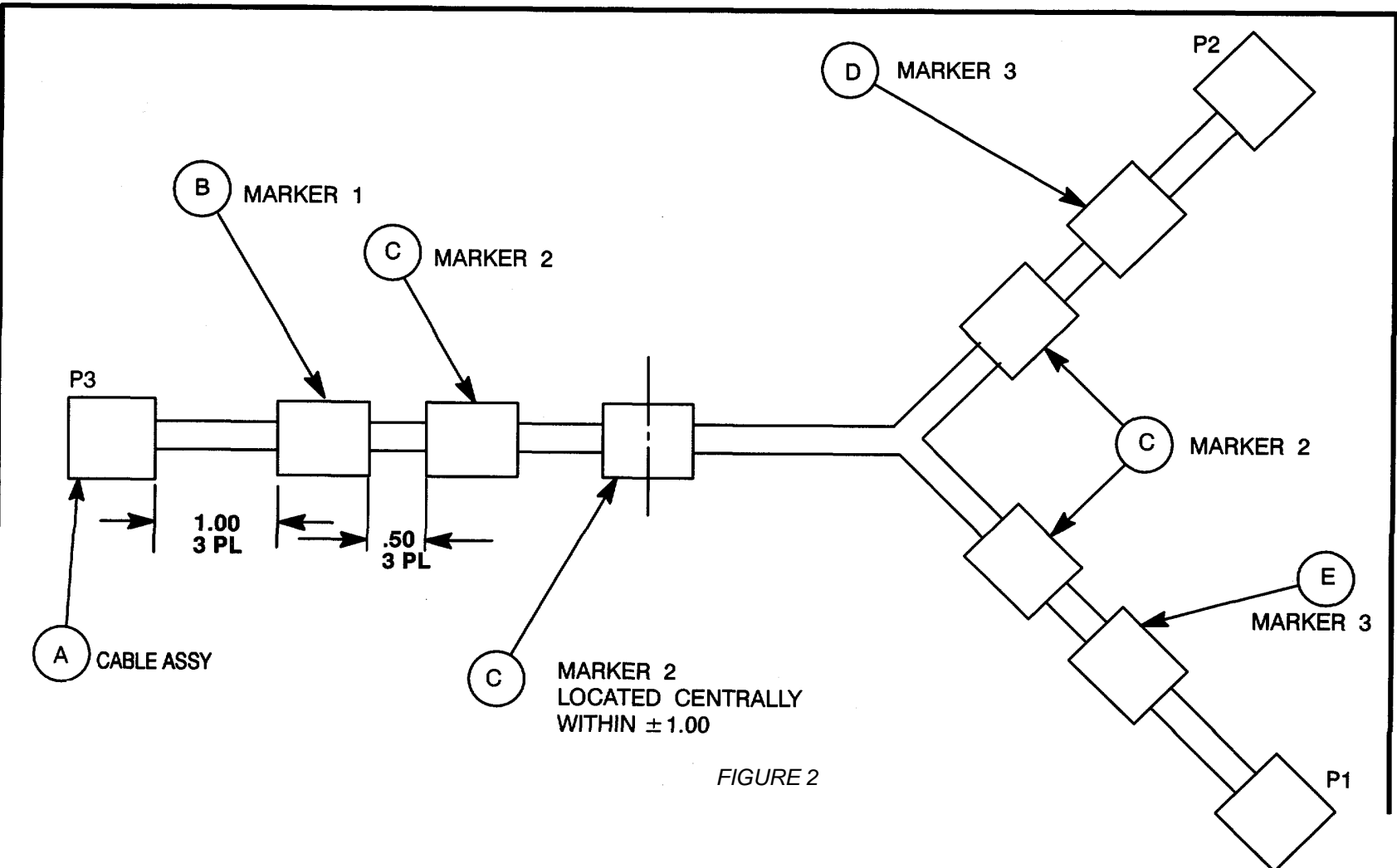

FIGURE 2

THIS DOCUMENT HAS BEEN PURCHASED BY THE GOVERNMENT AND MAY BE REPRODUCED AND USED IN CONNECTION WITH ANY GOVERNMENT PROCUREMENT OR MAINTENANCE OPERATION	SIZE	FSCM NO.	DRAWING NO.
	A	80063	A3093630
	SCALE	NONE	LTR A SHEET 8

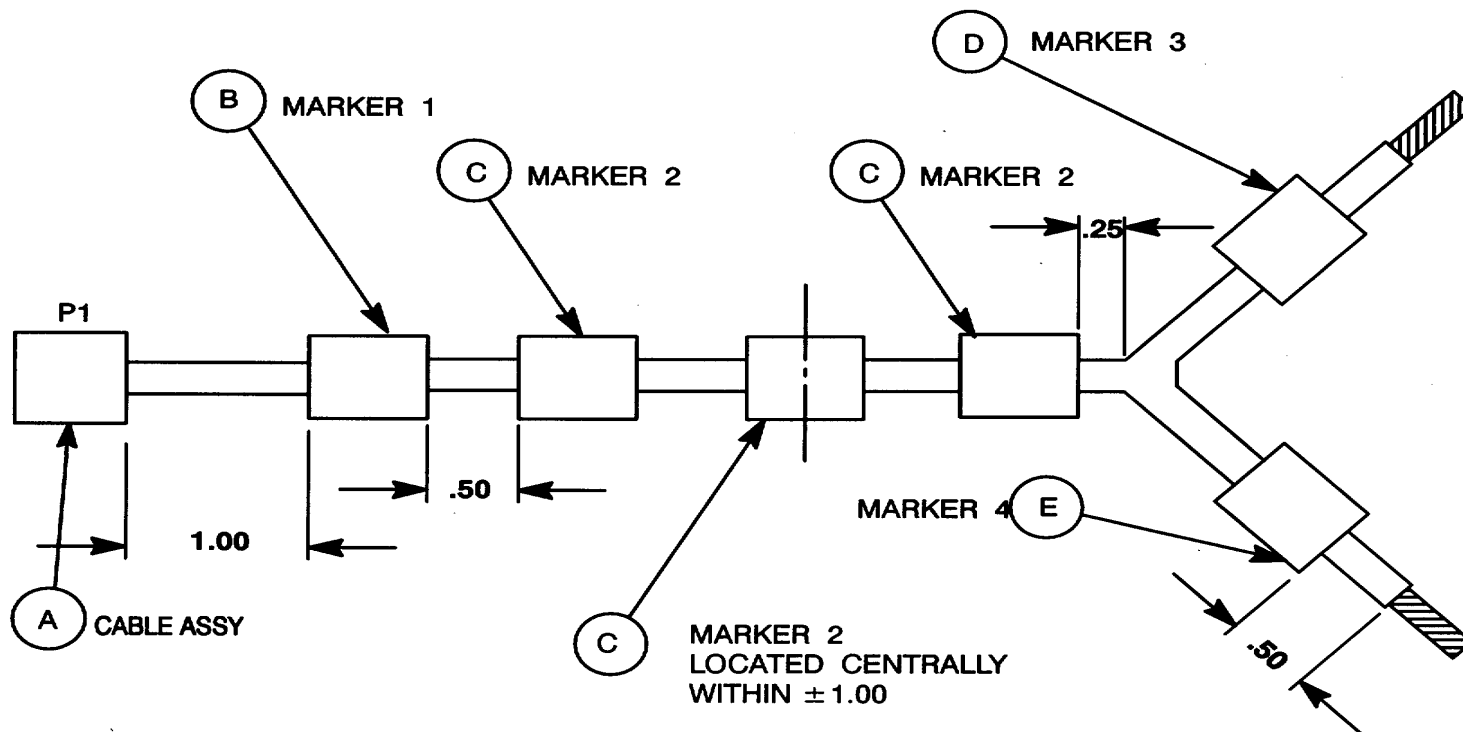

FIGURE 3

THIS DOCUMENT HAS BEEN PURCHASED BY THE GOVERNMENT AND MAY BE REPRODUCED AND USED IN CONNECTION WITH ANY GOVERNMENT PROCUREMENT OR MAINTENANCE OPERATION

SIZE
A
FSCM NO.
80063

DRAWING NO.
A3093630

SCALE NONE LTR A SHEET 9

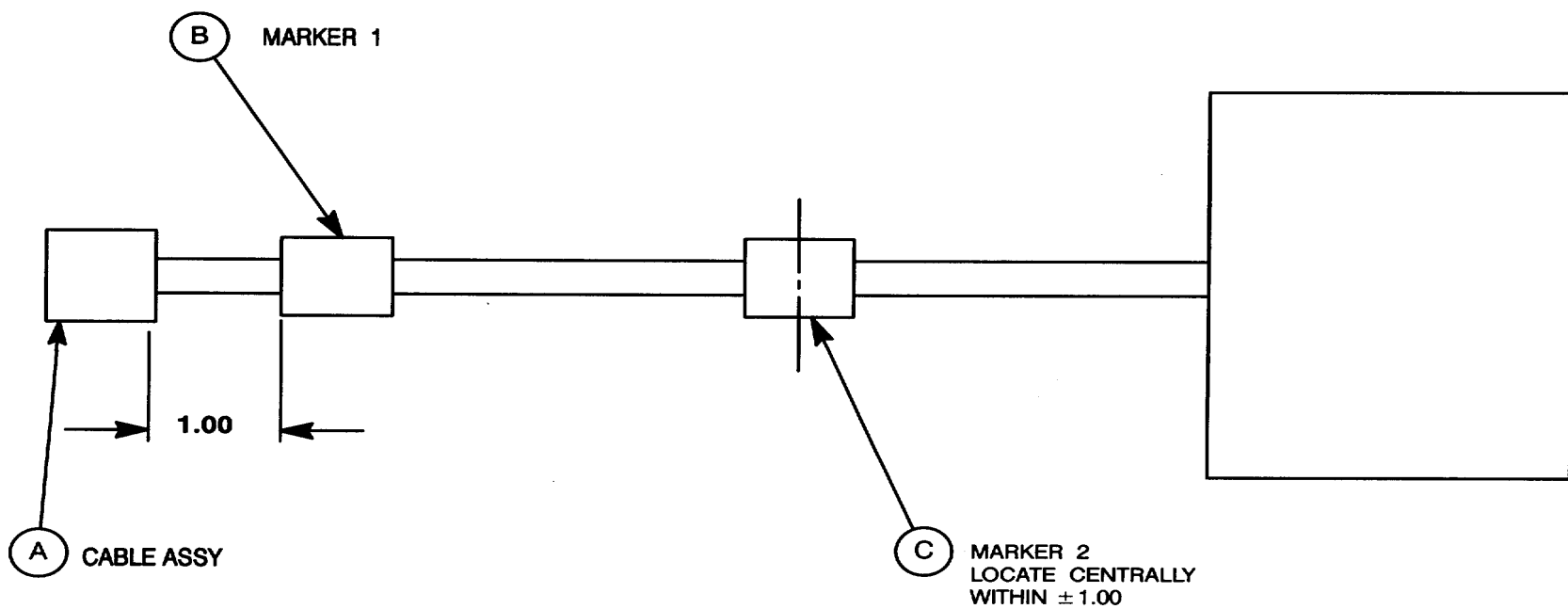

FIGURE 4

THIS DOCUMENT HAS BEEN PURCHASED BY THE GOVERNMENT AND MAY BE REPRODUCED AND USED IN CONNECTION WITH ANY GOVERNMENT PROCUREMENT OR MAINTENANCE OPERATION

SIZE
A
FSCM NO.
80063

DRAWING NO.
A3093630

SCALE NONE LTR A SHEET 10

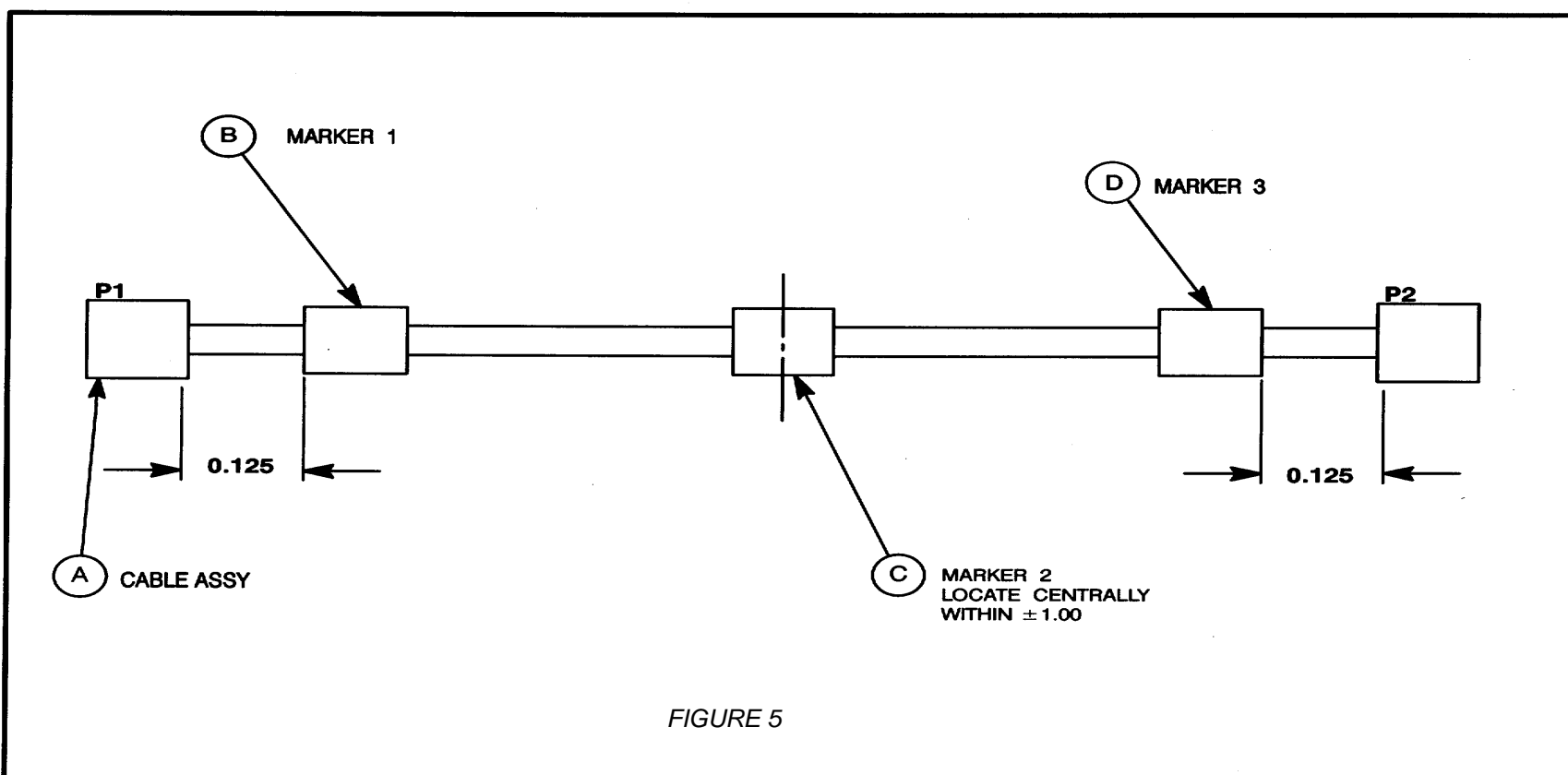

THIS DOCUMENT HAS BEEN PURCHASED BY THE GOVERNMENT AND MAY BE REPRODUCED AND USED IN CONNECTION WITH ANY GOVERNMENT PROCUREMENT OR MAINTENANCE OPERATION	SIZE	FSCM NO.	DRAWING NO.
	A	80063	A3093630
	SCALE	NONE	LTR H SHEET 11

PARTS LIST					
QTY	ITEM	PART NO.	DESCRIPTION	SPEC/STD	FSCM NO.
135	1	A3092925-5	MARKERS		80063
278	2	A3092925-4	MARKERS		80063
1	3	A3092669-1	CABLE ASSEMBLY, THIN HIRE TRIAX		80063
1	4	A3092669-3	CABLE ASSEMBLY, THIN WIRE TRIAX		80063
2	5	A3092669-4	CABLE ASSEMBLY, THIN WIRE TRIAX		80063
1	6	A3092669-5	CABLE ASSEMBLY, THIN WIRE TRIAX		80063
1	7	A3092673-1	CABLE ASSEMBLY, PATCH/FL		80063
1	8	A3093597-1	CABLE ASSEMBLY, TERMINAL INTERFACE		80063
	9				
2	10	A3093597-3	CABLE ASSEMBLY, TERMINAL INTERFACE		80063
2	11	A3093598	CABLE ASSEMBLY, AUI		80063
2	12	A3093599-1	CABLE ASSEMBLY, CP/PATCH		80063
4	13	A3093599-2	CABLE ASSEMBLY, CP/PATCH		80063
2	14	A3093599-3	CABLE ASSEMBLY, CP/PATCH		80063
4	15	A3093599-4	CABLE ASSEMBLY, CP/PATCH		80063
2	16	A3093599-5	CABLE ASSEMBLY, CP/PATCH		80063
2	17	A3093599-6	CABLE ASSEMBLY, CP/PATCH		80063

THIS DOCUMENT HAS BEEN PURCHASED BY THE GOVERNMENT AND MAY BE REPRODUCED AND USED IN CONNECTION WITH ANY GOVERNMENT PROCUREMENT OR MAINTENANCE OPERATION	SIZE	FSCM NO.	DRAWING NO.
	A	80063	A3093630
	SCALE	NONE	LTR H SHEET 12

QTY	ITEM	PART NO.	DESCRIPTION	SPEC/STD	FSCM NO.
1	18	A3093597-5	CABLE ASSEMBLY, CONSOLE		80063
1	19	A3093597-6	CABLE ASSEMBLY, CONSOLE		80063
1	20	A3093601-2	CABLE ASSEMBLY, FIBER OPTIC		80063
1	21	A3093601-3	CABLE ASSEMBLY, FIBER OPTIC		80063
1	22	A3093602-1	CABLE ASSEMBLY, PATCH/DSDI		80063
3	23	A3093602-2	CABLE ASSEMBLY, PATCH/DSDI		80063
3	24	A3093602-3	CABLE ASSEMBLY, PATCH/DSDI		80063
1	25	A3093602-4	CABLE ASSEMBLY, PATCH/DSDI		80063
1	26	A3093604	CABLE ASSEMBLY, WORKSTATION/PATCH		80063
1	27	A3093600-3	CABLE ASSEMBLY, WS/PATCH		80063
8	28	A3093605	CABLE ASSEMBLY, DSDI/KY68		80063
3	29	A3093606-1	CABLE ASSEMBLY, KY68/PATCH		80063
5	30	A3093606-2	CABLE ASSEMBLY, KY68/PATCH		80063
2	31	A3093606-3	CABLE ASSEMBLY, KY68/PATCH		80063
	32				
	33				
	34				

0307N	THIS DOCUMENT HAS BEEN PURCHASED BY THE GOVERNMENT AND MAY BE REPRODUCED AND USED IN CONNECTION WITH ANY GOVERNMENT PROCUREMENT OR MAINTENANCE OPERATION	SIZE	FSCM NO.	DRAWING NO.	
		A	80063	A3093630	
		SCALE	NONE	LTR	H SHEET 13

PARTS LIST					
QTY	ITEM	PART NO.	DESCRIPTION	SPEC/STD	FSCM NO.
	35				
	36	A3093607-1	CABLE ASSEMBLY, PATCH/LGM		80063
1	37	A3093607-2	CABLE ASSEMBLY, PATCH/LGM		80063
1	38	A3093608-2	CABLE ASSEMBLY, LGM/GM/OCU/PATCH		80063
2	39	A3093608-3	CABLE ASSEMBLY, LGM/GM/OCU/PATCH		80063
2	40	A3093609-2	CABLE ASSEMBLY, GM (ROA)/PATCH		80063
2	41	A3093610	CABLE ASSEMBLY, LINE DATA OUT		80063
2	42	A3093611	CABLE ASSEMBLY, LINE DATA IN		80063
2	43	A3093617	CABLE ASSEMBLY, PATCH/ROA		80063
1	44	A3093620-1	CABLE ASSEMBLY, KY68/PATCH		80063
1	45	A3093620-3	CABLE ASSEMBLY, KY68/PATCH		80063
1	46	A3093620-4	CABLE ASSEMBLY, KY68/PATCH		80063
1	47	A3093621-1	CABLE ASSEMBLY, PATCH/LDF		80063
2	48	A3093622	CABLE ASSEMBLY, PATCH/VEP (GM)		80063
1	49	A3093623-1	CABLE ASSEMBLY, PATCH/RAD		80063
2	50	A3093629-1	CABLE ASSEMBLY, PATCH/SEP		80063
1	51	A3093635	CABLE ASSEMBLY, AUDIO/POSTS		80063

	THIS DOCUMENT HAS BEEN PURCHASED BY THE GOVERNMENT AND MAY BE REPRODUCED AND USED IN CONNECTION WITH ANY GOVERNMENT PROCUREMENT OR MAINTENANCE OPERATION	SIZE	FSCM NO.	DRAWING NO.	
		A	80063	A3093630	
		SCALE	NONE	LTR	H SHEET 14

PARTS LIST					
QTY	ITEM	PART NO.	DESCRIPTION	SPEC/STD	FSCM NO.
1	52	A3093638-1	CABLE ASSEMBLY, CP/PATCH (ALARM)		80063
1	53	A3093638-2	CABLE ASSEMBLY, CP/PATCH (ALARM)		80063
1	54	A3093639-1	CABLE ASSEMBLY, RADIO/PATCH		80063
1	55	A3093641	CABLE ASSEMBLY, UPS/PATCH		80063
1	56	A3093643-2	CABLE ASSEMBLY, POWER FILTERED		80063
1	57	A3093643-3	CABLE ASSEMBLY, POWER FILTERED		80063
4	58	A3093644-1	CABLE ASSEMBLY, POWER 120 VAC		80063
4	59	A3093644-2	CABLE ASSEMBLY, POWER 120 VAC		80063
1	60	A3093582	CABLE ASSEMBLY, LGM/PATCH		80063
1	61	A3093646	CABLE ASSEMBLY, GM/PATCH		80063

0307N	THIS DOCUMENT HAS BEEN PURCHASED BY THE GOVERNMENT AND MAY BE REPRODUCED AND USED IN CONNECTION WITH ANY GOVERNMENT PROCUREMENT OR MAINTENANCE OPERATION	SIZE	FSCM NO.	DRAWING NO.
		A	80063	A3093630
		SCALE	NONE	LTR H SHEET 15

DASH NO.	A CABLE ASSY	FIGURE NO.	B MARKER 1	C MARKER 2	D MARKER 3	E MARKER 4	NOTES
1							
2	FIND NO. 2,3	1	P1 (A3A3A3A1A2J1)	W2 80063 A3093630-2	P2 (A3A3A3A2A2J2)		6
3	FIND NO. 1,21	2	P3 (A4J1)	W3 80063 A3093630-3	P2 (A3A3A3A1A1J2)	P1 (A3A3A3A1A1J1)	6
4	FIND NO. 2,5	1	P1 (A3A3A3A2A2J1)	W4 80063 A3093630-4	P2 (A3A3A5A2J2)		6
5	FIND NO. 1,20	2	P3 (A4J2)	W5 80063 A3093630-5	P2 (A3A3A3A2A1J2)	P1 (A3A3A3A2A1J1)	6
6	FIND NO. 2,28	1	P1 (A3A2A5A3J3)	W6 80063 A3093630-6	P2 (A3A2A5A1J2)		6
7	FIND NO. 2,31	1	P1 (A3A1A1J1)	W7 80063 A3093630-7	P2 (A3A2A5A1J1)		6
8	FIND NO. 2,37	1	P1 (A3A1A1J11)	W8 80063 A3093630-8	P2 (A3A1A2J1)		6
9	FIND NO. 1,59	1	P1 (A3A2J4)	W9 80063 A3093630-9	P2 (A3A2A5A3J1)		6

	THIS DOCUMENT HAS BEEN PURCHASED BY THE GOVERNMENT AND MAY BE REPRODUCED AND USED IN CONNECTION WITH ANY GOVERNMENT PROCUREMENT OR MAINTENANCE OPERATION	SIZE	FSCM NO.	DRAWING NO.
		A	80063	A3093630
		SCALE	NONE	LTR H SHEET 16

DASH NO.	A CABLE ASSY	FIGURE NO.	B MARKER 1	C MARKER 2	D MARKER 3	E MARKER 4	NOTES
10	FIND NO. 2,28	1	P1 (A3A2A5A4J3)	W10 A3093630-10	P2 80063 (A3A2A5A2J2)		6
11	FIND NO. 2,30	1	P1 (A3A1A1J2)	W11 80063 A3093630-11	P2 (A3A2A5A2J1)		6
12	FIND NO. 2,36	1	P1 (A3A1A1J2)	W12 80063 A3093630-12	P2 (A3A1A2J2)		6
13							
14	FIND NO. 2,15	1	P1 (A3A3A6A1J1)	W14 80063 A3093630-14	P2 (A3A3A1J1)		6
15	FIND NO. 2,25	1	P1 (A3A3A1J22)	W15 80063 A3093630-15	P2 (A3A2A5A3J2)		6
16	FIND NO. 1,58	1	P1 (A3A2J4)	W16 80063 A3093630-16	P2 (A3A2A5A4J1)		6
17	FIND NO. 2,28	1	P1 (A3A2A4A3J3)	W17 80063 A3093630-17	P2 (A3A2A4A1J2)		6
18	FIND NO. 2,30	1	P1 (A3A1A1J3)	W18 80063 A3093630-18	P2 (A3A2A4A1J1)		6

0307N	THIS DOCUMENT HAS BEEN PURCHASED BY THE GOVERNMENT AND MAY BE REPRODUCED AND USED IN CONNECTION WITH ANY GOVERNMENT PROCUREMENT OR MAINTENANCE OPERATION	SIZE	FSCM NO.	DRAWING NO.	
		A	80063	A3093630	
		SCALE	NONE	LTR	H SHEET 17

DASH NO.	A CABLE ASSY	FIGURE NO.	B MARKER 1	C MARKER 2	D MARKER 3	E MARKER 4	NOTES
19	FIND NO. 2,4	1	P1 (A3A3A5A2J1)	W19 80063 A3093630-19	P2 (A3A3A6A2J2)		6
20	FIND NO. 2,15	1	P1 (A3A3A6A1J2)	W20 80063 A3093630-20	P2 (A3A3A1J2)		6
21	FIND NO. 2,24	1	P1 (A3A3A1J23)	W21 80063 A3093630-21	P2 (A3A2A5A4J2)		6
22	FIND NO. 1,59	1	P1 (A3A2J3)	W22 80063 A3093630-22	P2 (A3A2A4A3J)		6
23	FIND NO. 2,15	1	P1 (A3A3A6A1J3)	W23 80063 A3093630-23	P2 (A3A3A1J3)		6
24	FIND NO. 2,24	1	P1 (A3A3A1J24)	W24 80063 A3093630-24	P2 (A3A2A4A3J2)		6
25	FIND NO. 2,28	1	P1 (A3A2A4A4J3)	W25 80063 A3093630-25	P2 (A3A2A4A2J2)		6
26	FIND NO. 2,30	1	P1 (A3A1A1J4)	W26 80063 A3093630-26	P2 (A3A2A4A2J1)		6
27	FIND NO. 2,17	1	P1 (A3A2A6A1J4)	W27 80063 A3093630-27	P2 (A3A2A1J4)		6

	THIS DOCUMENT HAS BEEN PURCHASED BY THE GOVERNMENT AND MAY BE REPRODUCED AND USED IN CONNECTION WITH ANY GOVERNMENT PROCUREMENT OR MAINTENANCE OPERATION	SIZE	FSCM NO.	DRAWING NO.	
		A	80063	A3093630	
		SCALE	NONE	LTR	H SHEET 18

DASH NO.	A CABLE ASSY	FIGURE NO.	B MARKER 1	C MARKER 2	D MARKER 3	E MARKER 4	NOTES
28	FIND NO. 2,24	1	P1 (A3A3A1J25)	W28 80063 A3093630-28	P2 (A3A2A4A4J2)		6
29	FIND NO. 2,17	1	P1 (A3A3A6A1J5)	W29 80063 A3093630-29	P2 (A3A3A1J5)		6
30	FIND NO. 2,23	1	P1 (A3A3A1 J26)	W30 80063 A3093630-30	P2 (A3A2A3A3J2)		6
31	FIND NO. 1,58	1	P1 (A3A2J3)	W31 80063 A3093630-31	P2 (A3A2A4A4J1)		6
32	FIND NO. 2,16	1	P1 (A3A3A6A1J6)	W32 80063 A3093630-32	P2 (A3A3A1J6)		6
33	FIND NO. 2,23	1	P1 (A3A3A1 J27)	W33 80063 A3093630-33	P2 (A3A2A3A4J2)		6
34	FIND NO. 2,5	1	P1 (A3A3A6A2J 1)	W34 80063 A3093630-34	P2 (A3A3A4A2J2)		6
35	FIND NO. 2,15	1	P1 (A3A3A6A1J7)	W35 80063 A3093630-35	P2 (A3A3A1J7)		6
36	FIND NO. 2,23	1	P1 (A3A3A1 J 28)	W36 80063 A3093630-36	P2 (A3A2A2A3J2)		6

0307N	THIS DOCUMENT HAS BEEN PURCHASED BY THE GOVERNMENT AND MAY BE REPRODUCED AND USED IN CONNECTION WITH ANY GOVERNMENT PROCUREMENT OR MAINTENANCE OPERATION	SIZE	FSCM NO.	DRAWING NO.
		A	80063	A3093630
		SCALE	NONE	LTR H SHEET 19

DASH NO.	A CABLE ASSY	FIGURE NO.	B MARKER 1	C MARKER 2	D MARKER 3	E MARKER 4	NOTES
37	FIND NO. 2,28	1	P1 (A3A2A3A3J3)	W37 A3093630-37	P2 80063 (A3A2A3A1J2)		6
38	FIND NO. 2,29	1	P1 (A3A1A1J5)	W38 80063 A3093630-38	P2 (A3A2A3A1J1)		6
39	FIND NO. 2,16	1	P1 (A3A3A6A1J8)	W39 80063 A3093630-39	P2 (A3A3A1J8)		6
40	FIND NO. 2,22	1	P1 (A3A3A1J29)	W40 80063 A3093630-40	P2 (A3A2A2A4J2)		6
41	FIND NO. 1,59	1	P1 (A3A2J2)	W41 80063 A3093630-41	P2 (A3A2A3A3J1)		6
42	FIND NO. 2,28	1	P1 (A3A2A3A4J3)	W42 80063 A3093630-42	P2 (A3A2A3A2J2)		6
43	FIND NO. 2,29	1	P1 (A3A1A1J6)	W43 80063 A3093630-43	P2 (A3A2A3A2J1)		6
44	FIND NO. 1,58	1	P1 (A3A2J2)	W44 80063 A3093630-44	P2 (A3A2A3A4J1)		6
45	FIND NO. 2,13	1	P1 (A3A3A4A1J1)	W45 80063 A3093630-45	P2 (A3A3A1J9)		6

THIS DOCUMENT HAS BEEN PURCHASED BY THE GOVERNMENT AND MAY BE REPRODUCED AND USED IN CONNECTION WITH ANY GOVERNMENT PROCUREMENT OR MAINTENANCE OPERATION	SIZE	FSCM NO.	DRAWING NO.
	A	80063	A3093630
		SCALE	NONE LTR H SHEET 20

DASH NO.	A CABLE ASSY	FIGURE NO.	B MARKER 1	C MARKER 2	D MARKER 3	E MARKER 4	NOTES
46	FIND NO. 2,6	1	P1 (A3A3A4A2J 1)	W46 80063 A3093630-46	P2 (A8J6)		6
47	FIND NO. 2,14	1	P1 (A3A3A4A1J2)	W47 80063 A3093630-47	P2 (A3A3A1J10)		6
48	FIND NO. 2,28	1	P1 (A3A2A2A3J3)	W48 80063 A3093630-48	P2. (A3A2A2AIJ2)		6
49	FIND NO. 2,31	1	P1 (A3A1AIJ7)	W49 80063 A3093630-49	P2 (A3A2A2ALJ1)		6
50	FIND NO. 2,13	1	P1 (A3A3A4A1J3)	W50 80063 A3093630-50	P2 (A3A3AIJ11)		6
51	FIND NO. 2,13	1	P1 (A3A3A4A1J4)	W52 80063 A3093630-51	P2 (A3A3A1J 12)		6
52	FIND NO. 1,59	1	P1 (A3A2J1)	W53 80063 A3093630-52	P2 (A3A2A2A3J1)		6
53	FIND NO. 2,12	1	P1 (A3A3A4A1J5)	W54 80063 A3093630-53	P2 (A3A3AIJ13)		6
54	FIND NO. 2,28	1	P1 (A3A2A2A4 J3)	W55 80063 A3093630-54	P2 (A3A2A2A2J2)		6

0307N	THIS DOCUMENT HAS BEEN PURCHASED BY THE GOVERNMENT AND MAY BE REPRO- DUCED AND USED IN CONNECTION WITH ANY GOVERNMENT PROCUREMENT OR MAINTENANCE OPERATION	SIZE	FSCM NO.	DRAWING NO.	
		A	80063	A3093630	
		SCALE	NONE	LTR	H SHEET 21

DASH NO.	A CABLE ASSY	FIGURE NO.	B MARKER 1	C MARKER 2	D MARKER 3	E MARKER 4	NOTES
55	FIND NO. 2,30	1	P1 (A3A1AIJ8)	W56 80063 A3093630-55	P2 (A3A2A2A2J1)		6
56	FIND NO. 2,13	1	P1 (A3A3A4A1J6)	W57 80063 A3093630-56	P2 (A3A3A1J 14)		6
57	FIND NO. 2,47	1	P1 (A3A3A1J32)	W58 80063 A3093630-57	P2 (A7A2J1)		6
58	FIND NO. 2,14	1	P1 (A3A3A4A1J7)	W59 80063 A3093630-58	P2 (A3A3A1J15)		6
59	FIND NO. 1,58	1	P1 (A3A2J)	W60 80063 A3093630-59	P2 (A3A2A2A4J)		6
60	FIND NO. 2,12	1	P1 (A3A3A4A1J8)	W61 80063 A3093630-60	P2 (A3A3AJ 16)		6
61	FIND NO. 2,50	1	P1 (A3A1A1J13)	W62 80063 A3093630-61	P2 (A5J1)		6
62							
63	FIND NO. 2,46	1	P1 (A12J1)	W64 80063 A3093630-63	P2 (A3A2A1A1J2)		6

THIS DOCUMENT HAS BEEN PURCHASED BY THE GOVERNMENT AND MAY BE REPRO- DUCED AND USED IN CONNECTION WITH ANY GOVERNMENT PROCUREMENT OR MAINTENANCE OPERATION	SIZE	FSCM NO.	DRAWING NO.	
	A	80063	A3093630	
		SCALE	NONE	LTR H SHEET 22

DASH NO.	A CABLE ASSY	FIGURE NO.	B MARKER 1	C MARKER 2	D MARKER 3	E MARKER 4	NOTES
64	FIND NO. 2, 30	1	P1 (A3A1A1J9)	W65 80063 A3093630-64	P2 (A3A2A1A1J1)		6
65 66	FIND NO. 2, 45	1	P1 (A3A3A1J30)	W70 80063 A3093630-66	P2 (A13J1)		6
67	FIND NO. 2, 44	1	P1 (A3A3A1J31)	W74 80063 A3093630-67	P2 (A3A2A1A2J2)		6
68	FIND NO. 2, 29	1	P1 (A3A1A1J10)	W75 80063 A3093630-68	P2 (A3A2A1A2J1)		6
69	FIND NO. 2, 61	1	P1 (A3A3A1J37)	W76 80063 A3093630-69	P2 (A3A1A3J11)		6
70	FIND NO. 2, 19	1	P1 (A3A3A1J17)	W77 80063 A3093630-70	P2 (A8J2)		6
71	FIND NO. 2, 27	1	P1 (A7A3J1)	W78 80063 A3093630-71	P2 (A3A3A1J33)		6
72	FIND NO. 2, 18	1	P1 (A3A3A1J18)	W79 80063 A3093630-72	P2 (A9J2)		6

0307N	THIS DOCUMENT HAS BEEN PURCHASED BY THE GOVERNMENT AND MAY BE REPRODUCED AND USED IN CONNECTION WITH ANY GOVERNMENT PROCUREMENT OR MAINTENANCE OPERATION	SIZE	FSCM NO.	DRAWING NO.	
		A	80063	A3093630	
		SCALE	NONE	LTR	H SHEET 23

DASH NO.	A CABLE ASSY	FIGURE NO.	B MARKER 1	C MARKER 2	D MARKER 3	E MARKER 4	NOTES
73	FIND NO. 2, 60	1	P1 (A3A3A1J38)	W81 80063 A3093630-73	P2 (A3A1A2J4)		6
74	FIND NO. 2, 10	1	P1 (A3A3A1J20)	W82 80063 A3093630-74	P2 (A3A3A6A1J10)		6
75	FIND NO. 2, 8	1	P1 (A3A3A1J19)	W83 80063 A3093630-75	P2 (A3A3A4J10)		6
76	FIND NO. 2, 10	1	P1 (A3A3A1J21)	W84 80063 A3093630-76	P2 (A3A3A5A1J10)		6
77	FIND NO. 2, 26	1	P1 (A8J1)	W86 A3093630-77	P2 80063 (A3A3A1J35)		6
78	FIND NO. 2, 38	1	P1 (A3A1A2J3)	W87 A3093630-78	P2 80063 (A3A1A1J14)		6
79	FIND NO. 2, 56	1	P1 (A3A1A2J5)	W88 A3093630-79	P2 80063 (A3A1A4J1)		6
80	FIND NO. 2, 40	1	P1 (A3A1A3J18)	W89 A3093630-80	P2 80063 (A3A1A1J17)		6
81	FIND NO. 2, 40	1	P1 (A3A1A3J19)	W90 80063 A3093630-81	P2 (A3A1A1J18)		6

THIS DOCUMENT HAS BEEN PURCHASED BY THE GOVERNMENT AND MAY BE REPRODUCED AND USED IN CONNECTION WITH ANY GOVERNMENT PROCUREMENT OR MAINTENANCE OPERATION	SIZE	FSCM NO.	DRAWING NO.	
	A	80063	A3093630	
		SCALE	NONE	LTR H SHEET 24

DASH NO.	A CABLE ASSY	FIGURE NO.	B MARKER 1	C MARKER 2	D MARKER 3	E MARKER 4	NOTES
82	FIND NO. 2, 39	1	P1 (A3A1A3J13)	W91 80063 A3093630-82	P2 (A3A1A1J15)		6
83	FIND NO. 2, 39	1	P1 (A3A1A3J14)	W92 80063 A3093630-83	P2 (A3A1A1J16)		6
84	FIND NO. 1, 41	1	P1 (A3A1A3J1)	W95 80063 A3093630-84	P2 (A3A1A1J19)		6
85	FIND NO. 1, 42	1	P1 (A3A1A3J2)	W96 80063 A3093630-85	P2 (A3A1A1J20)		6
86	FIND NO. 2, 43	1	P1 (A3A1A1J23)	W97 80063 A3093630-86	P2 (A4J3)		6
87	FIND NO. 1, 41	1	P1 (A3A1A3J3)	W98 80063 A3093630-87	P2 (A3A1A1J21)		6
88	FIND NO. 1, 42	1	P1 (A3A1A3J4)	W99 80063 A3093630-88	P2 (A3A1A1J22)		6
89	FIND NO. 2, 43	1	P1 (A3A1A1J24)	W100 80063 A3093630-89	P2 (A4J4)		6
90	FIND NO. 1, 50	1	P1 (A3A1A1J29)	W101 80063 A3093630-90	P2 (A5J2)		6

0307N	THIS DOCUMENT HAS BEEN PURCHASED BY THE GOVERNMENT AND MAY BE REPRODUCED AND USED IN CONNECTION WITH ANY GOVERNMENT PROCUREMENT OR MAINTENANCE OPERATION	SIZE A	FSCM NO. 80063	DRAWING NO. A3093630	
		SCALE NONE	LTR	H	SHEET 25

DASH NO.	A CABLE ASSY	FIGURE NO.	B MARKER 1	C MARKER 2	D MARKER 3	E MARKER 4	NOTES
91							
92	FIND NO. 1, 53	1	P1 (A3A3A1J40)	W103 80063 A3093630-92	P2 (A3A3A6A1J9)		6
93	FIND NO. 2, 57	1	P1 (A3A1A3J17)	W105 80063 A3093630-93	P2 (A3A1A4J2)		6
94	FIND NO. 1, 48	1	P1 (A3A1A1J25)	W106 80063 A3093630-94	P2 (A5J3)		6
95	FIND NO. 1, 48	1	P1 (A3A1A1J26)	W107 80063 A3093630-95	P2 (A5J4)		6
96	FIND NO. 1, 51	1	P1 (A3A1A1J28)	W108 80063 A3093630-96	P2 (A5J5)		6
97	FIND NO. 1, 7	3	P1 (A3A1A1J27)	W109 80063 A3093630-97	E1 (A16E1)	E2 (A16E2)	6
98							
99	FIND NO. 2, 11	1	P1 (A3A3A3A2A2J3)	W114 80063 A3093630-99	P2 (A3A3A3A2A1J3)		6
100	FIND NO. 2, 11	5	P1 (A3A3A3A1A2J3)	W115 80063 A3093630-100	P2 (A3A3A3A1A1J3)		6

THIS DOCUMENT HAS BEEN PURCHASED BY THE GOVERNMENT AND MAY BE REPRODUCED AND USED IN CONNECTION WITH ANY GOVERNMENT PROCUREMENT OR MAINTENANCE OPERATION	SIZE A	FSCM NO. 80063	DRAWING NO. A3093630	
	SCALE NONE	LTR	H	SHEET 26

A3093630

CABLE SET, DATA RACK-AN/TYQ-30 (Sheets 25 & 26 of 27)

DASH NO.	A CABLE ASSY	FIGURE NO.	B MARKER 1	C MARKER 2	D MARKER 3	E MARKER 4	NOTES
101	FIND NO. 2, 52	1	P1 (A3A3A1J41)	W116 80063 A3093630-101	P2 (A3A3A4A1J9)		6
102	FIND NO. 1, 49	1	P1 (A15A1J3)	W126 80063 A3093630-102	P2 (A3A3A1J34)		6
103	FIND NO. 1, 54	1	P1 (A7A5A1J1) VRC 46 OR (A15A6J4) VRC 90	W127 80063 A3093630-103	P2 (A3A3A1J36)		6
104	FIND NO. 1, 55	1	P1 (A3A3A1J39)	W401 80063 A3093630-104	P2 (A2A1A1J9)		6

0307N	THIS DOCUMENT HAS BEEN PURCHASED BY THE GOVERNMENT AND MAY BE REPRODUCED AND USED IN CONNECTION WITH ANY GOVERNMENT PROCUREMENT OR MAINTENANCE OPERATION	SIZE	FSCM NO.	DRAWING NO.	
		A	80063	A3093630	
		SCALE	NONE	LTR	H SHEET 27

A3093630

CABLE SET, DATA RACK-AN/TYQ-30 (Sheets 27 of 27)

NOTES:

1. PREPARED IN ACCORDANCE WITH DOD-STD-100.
2. UNLESS OTHERWISE SPECIFIED, DIMENSIONS ARE IN INCHES.
3. UNLESS OTHERWISE SPECIFIED, TOLERANCES ARE: 2 PLACE DECIMALS $\pm .02$, 3 PLACE DECIMALS $\pm .010$, FRACTIONS $\pm 1/32$, ANGLES ± 1 DEGREE, AND HOLE DIAMETERS $\pm .005$.
4. WORKMANSHIP SHALL BE IN ACCORDANCE WITH MIL-STD-454, REQUIREMENT 9.
5. DIMENSIONAL DATA IS BASED ON AMERICAN NATIONAL STANDARD ANSI Y14.5-1973.
6. MARK PER A3092959, DECAL FABRICATION.
7. PARTIAL REFERENCE DESIGNATIONS ARE SHOWN. FOR COMPLETE REFERENCE DESIGNATION, PREFIX WITH UNIT NUMBER AND SUBASSEMBLY DESIGNATION.
8. COMPLETE PART NUMBER SHALL INCLUDE APPLICABLE DASH NUMBER.
9. CABLE MARKERS MAY BE APPLIED TO CABLES SUCH THAT MARKERS READ EITHER AWAY FROM CABLE END OR TOWARDS CABLE END.

0430N	THIS DOCUMENT HAS BEEN PURCHASED BY THE GOVERNMENT AND MAY BE REPRODUCED AND USED IN CONNECTION WITH ANY GOVERNMENT PROCUREMENT OR MAINTENANCE OPERATION	SIZE	FSCM NO.	DRAWING NO.	
		A	80063	A3093631	
		SCALE	NONE	LTR	E SHEET 3

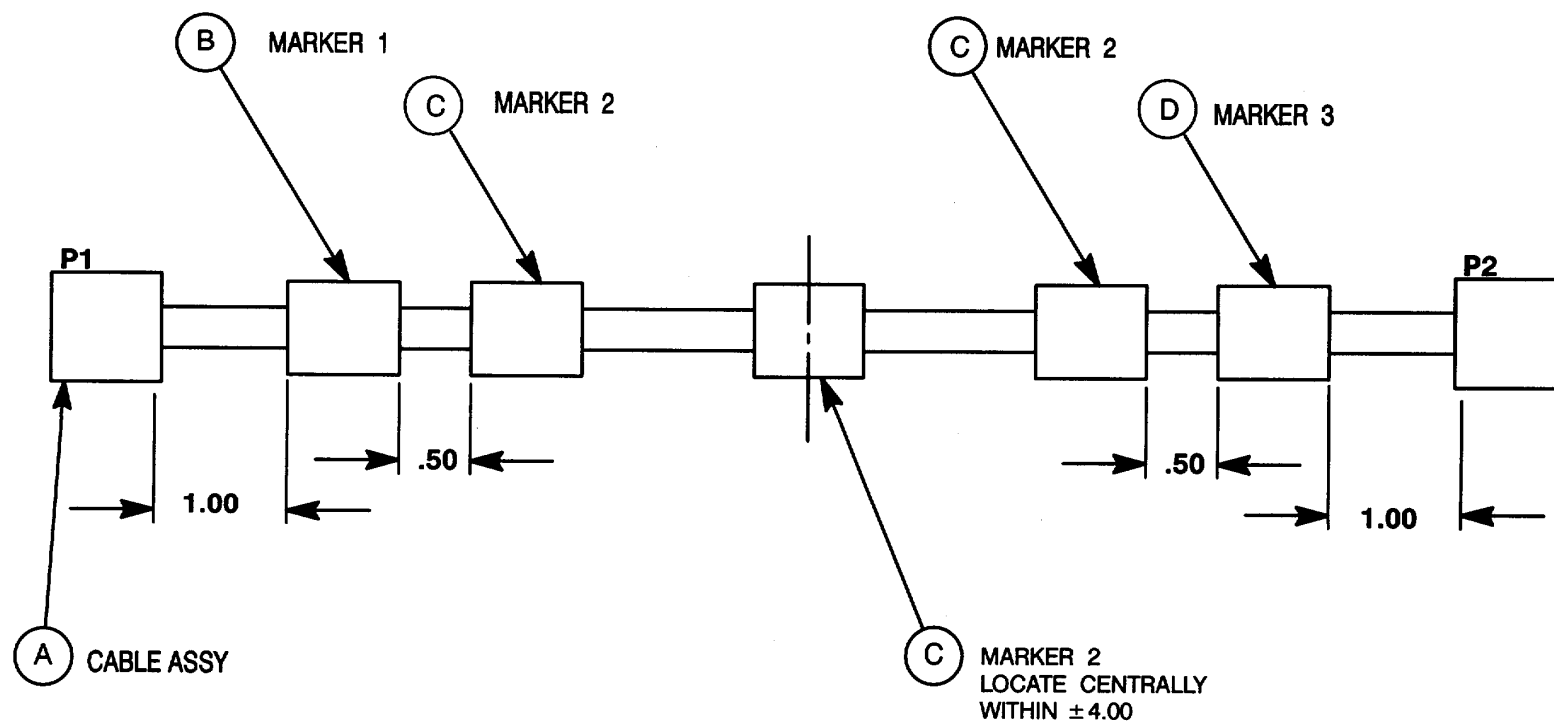

FIGURE 1

THIS DOCUMENT HAS BEEN PURCHASED BY THE GOVERNMENT AND MAY BE REPRODUCED AND USED IN CONNECTION WITH ANY GOVERNMENT PROCUREMENT OR MAINTENANCE OPERATION	SIZE	FSCM NO.	DRAWING NO.	
	A	80063	A3093631	
		SCALE	NONE	LTR A SHEET 4

A3093631

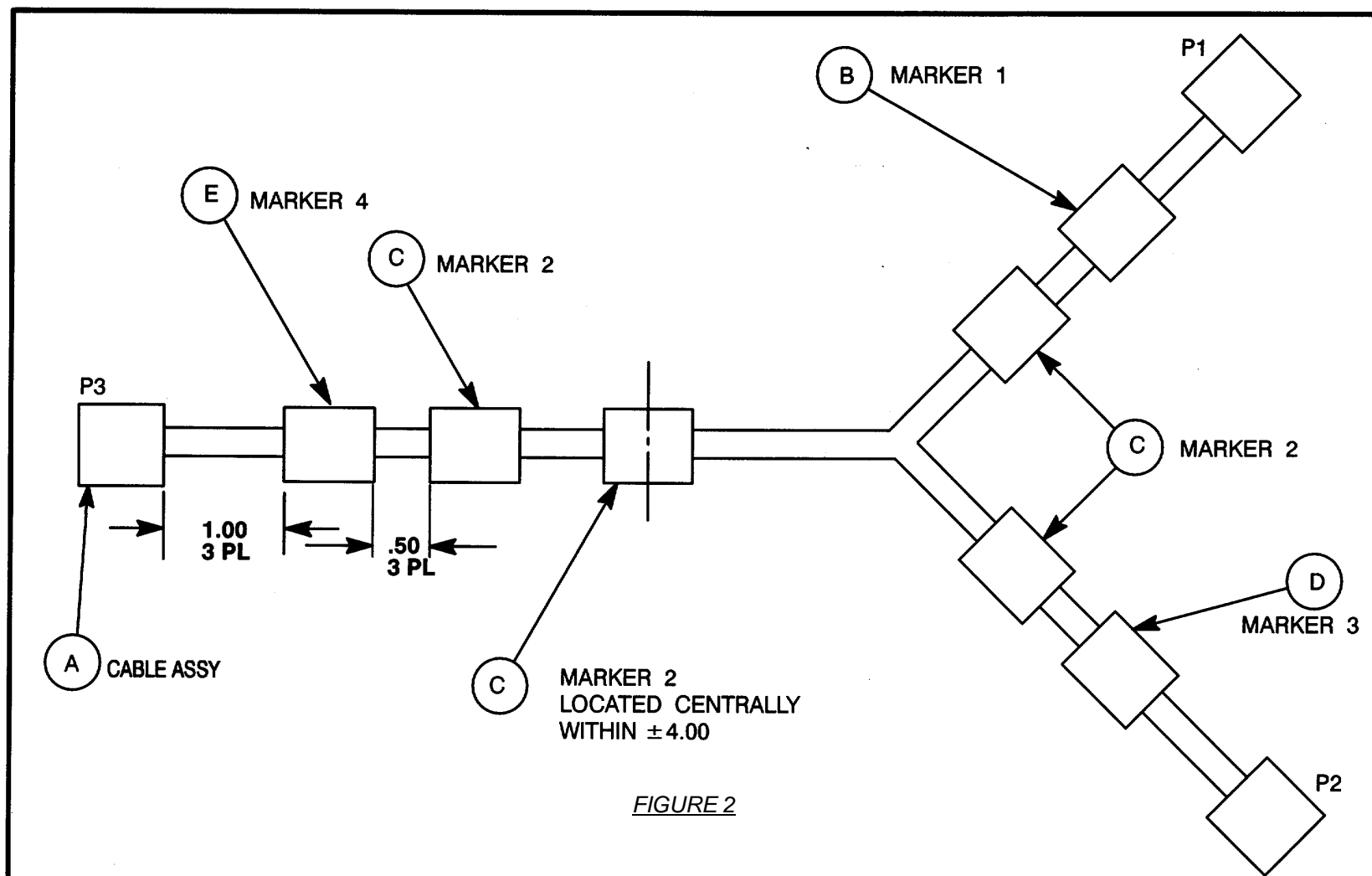

FIGURE 2

THIS DOCUMENT HAS BEEN PURCHASED BY THE GOVERNMENT AND MAY BE REPRODUCED AND USED IN CONNECTION WITH ANY GOVERNMENT PROCUREMENT OR MAINTENANCE OPERATION	SIZE	FSCM NO.	DRAWING NO.	
	A	80063	A3093631	
SCALE	NONE	LTR	A	SHEET 5

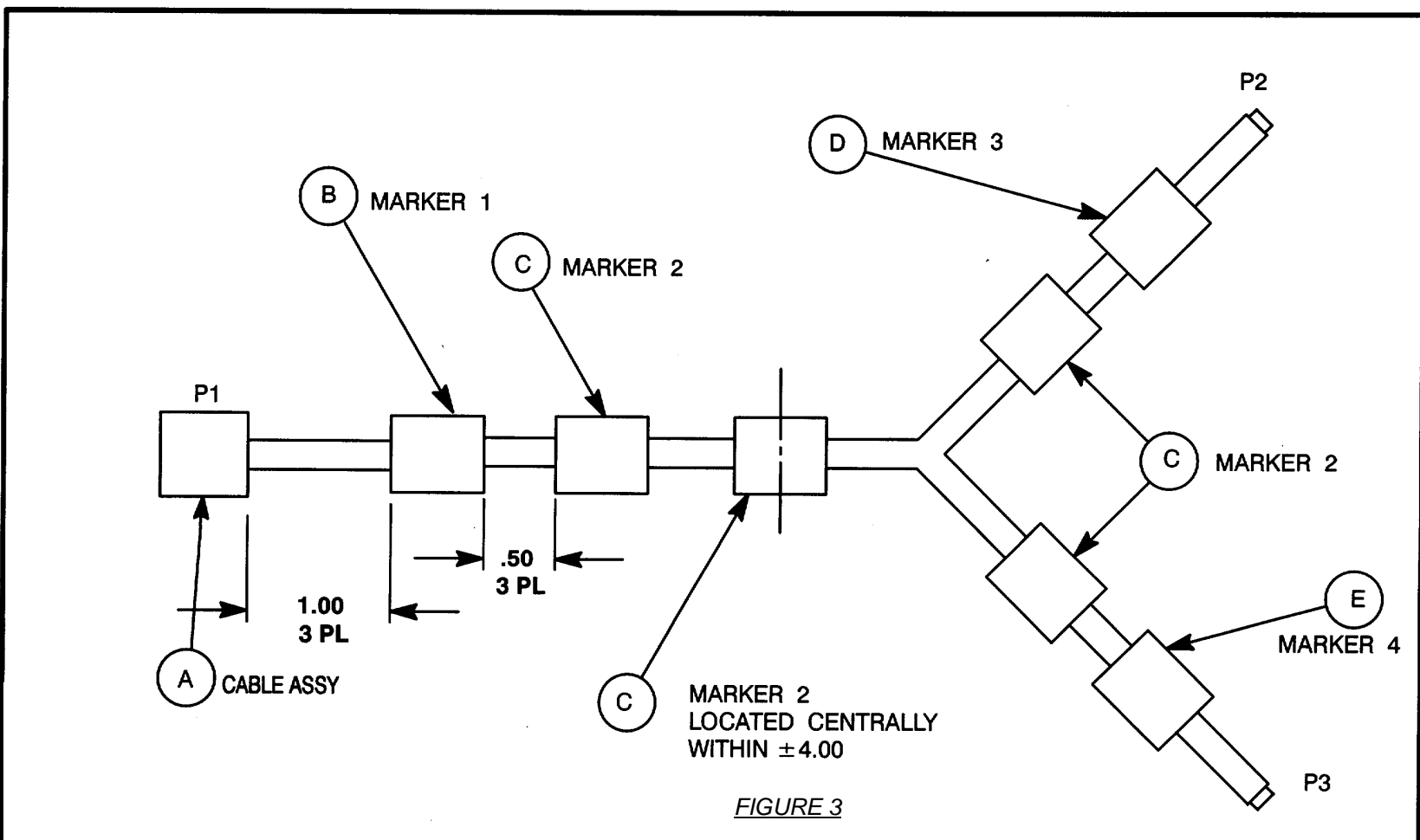

FIGURE 3

THIS DOCUMENT HAS BEEN PURCHASED BY THE GOVERNMENT AND MAY BE REPRODUCED AND USED IN CONNECTION WITH ANY GOVERNMENT PROCUREMENT OR MAINTENANCE OPERATION	SIZE	FSCM NO.	DRAWING NO.	
	A	80063	A3093631	
SCALE	NONE	LTR	D	SHEET 6

A3093631

PARTS LIST					
QTY	ITEM	PART NO.	DESCRIPTION	SPEC/STD	FSCM NO.
5	1	A3092925-5	MARKERS		80063
132	2	A3092925-4	MARKERS		80063
1	3	A3092668-2	CABLE ASSY, RADIO/ENTRY CONTROL		80063
1	4	A3092669-3	CABLE ASSEMBLY, THIN WIRE TRIAX		80063
1	5	A3092673-2	CABLE ASSEMBLY, PATCH/LS147		80063
1	6	A3093597-5	CABLE ASSEMBLY, CONSOLE		80063
1	7	A3093597-7	CABLE ASSEMBLY, CONSOLE		80063
1	8	A3093597-4	CABLE ASSEMBLY, CONSOLE		80063
1	9	A3093601-4	CABLE ASSEMBLY, FIBER OPTIC		80063
1	10	A3093600-2	CABLE ASSEMBLY, WS/PATCH		80063
1	11	A3093600-1	CABLE ASSEMBLY, WS/PATCH		80063
1	12	A3093606-1	CABLE ASSEMBLY, KY68/PATCH		80063
2	13	A3093606-2	CABLE ASSEMBLY, KY68/PATCH		80063
1	14	A3093606-4	CABLE ASSEMBLY, KY68/PATCH		80063
1	15	A3093620-8	CABLE ASSEMBLY, KY68/PATCH		80063
1	16	A3093620-7	CABLE ASSEMBLY, KY68/PATCH		80063
1	17	A3093620-5	CABLE ASSEMBLY, KY68/PATCH		80063

0430N	THIS DOCUMENT HAS BEEN PURCHASED BY THE GOVERNMENT AND MAY BE REPRODUCED AND USED IN CONNECTION WITH ANY GOVERNMENT PROCUREMENT OR MAINTENANCE OPERATION	SIZE A	FSCM NO. 80063	DRAWING NO. A3093631
		SCALE NONE	LTR F	SHEET 7

PARTS LIST					
QTY	ITEM	PART NO.	DESCRIPTION	SPEC/STD	FSCM NO.
1	18	A3093620-6	CABLE ASSEMBLY, KY68/PATCH		80063
1	19	A3093621-2	CABLE ASSEMBLY, PATCH/LDF		80063
1	20	A3093623-2	CABLE ASSEMBLY, PATCH/RADIO		80063
1	21	A3093628-3	CABLE ASSEMBLY, RAD/ANT		80063
1	22	A3093629-2	CABLE ASSEMBLY, PATCH/SEP		80063
1	23	A3093635	CABLE ASSEMBLY, AUDIO/POSTS		80063
1	24	A3093639-2	CABLE ASSEMBLY, RADIO/PATCH		80063
1	25	A3093644-2	CABLE ASSEMBLY, POWER 120 VAC		80063
1	26	A3093645-2	CABLE ASSEMBLY, POWER 28 VDC		80062
1	27	A3093597-8	CABLE ASSEMBLY, CONSOLE		80063
1	28	A3093620-9	CABLE ASSEMBLY, KY68/PATCH		80063

THIS DOCUMENT HAS BEEN PURCHASED BY THE GOVERNMENT AND MAY BE REPRODUCED AND USED IN CONNECTION WITH ANY GOVERNMENT PROCUREMENT OR MAINTENANCE OPERATION	SIZE A	FSCM NO. 80063	DRAWING NO. A3093631
		SCALE NONE	LTR B SHEET 8

A3093631

CABLE SET, EQUIPMENT RACK, OPN (Sheets 7 & 8 of 12)

DASH NO.	A CABLE ASSY	FIGURE NO.	B MARKER 1	C MARKER 2	D MARKER 3	E MARKER 4	NOTES
1	FIND NO. 1, 25	1	P1 (A3J1)	W1 80063 A3093631-1	P2 (A3A3A1J3)		6
2	FIND NO. 2, 9	2	P1 (A3A3A1J1)	W2 80063 A3093631-2	P2 (A3A3A1J2)	P3 (A4J2)	6
3	FIND NO. 2, 4	1	P1 (A3A3A1J5)	W4 80063 A3093631-3	P2 (A7J5)		6
4	FIND NO. 2, 13	1	P1 (A3A2J1)	W5 80063 A3093631, -4	P2 (A3A4A1J1)		6
5	FIND NO. 2, 23	1	P1 (A4J3)	W6 80063 A3093631-5	P2 (A3A2J6)		6
6	FIND NO. 2, 15	1	P1 (A12J1)	W7 80063 A3093631-6	P2 (A3A4A1J2)		6
7	FIND NO. 2, 28	1	P1 (A13J1)	W10 80063 A3093631-7	P2 (A3A4A2J2)		6
8	FIND NO. 2, 12	1	P1 (A3A2J2)	W11 80063 A3093631-8	P2 (A3A4A2J1)		6
9	FIND NO. 2, 8	1	P1 (A3A1J1)	W16 80063 A3093631-9	P2 (A7J2)		6

**THIS DOCUMENT HAS BEEN PURCHASED
BY THE GOVERNMENT AND MAY BE REPRO-
DUCED AND USED IN CONNECTION WITH
ANY GOVERNMENT PROCUREMENT OR
MAINTENANCE OPERATION**

SIZE
A

FSCM NO.
80063

DRAWING NO.
A3093631

0430N

SCALE NONE **LTR** A **SHEET 9**

DASH NO.	A CABLE ASSY	FIGURE NO.	B MARKER 1	C MARKER 2	D MARKER 3	E MARKER 4	NOTES
10	FIND NO. 2, 7	1	P1 (A3A1J2)	W17 80063 A3093631-10	P2 (A8J2)		6
11	FIND NO. 2, 11	1	P1 (A9J1)	W19 80063 A3093631-11	P2 (A3A1J5)		6
12	FIND NO. 2, 10	1	P1 (A22J1)	W22 80063 A3093631-12	P2 (A3A1J6)		6
13	FIND NO. 2, 17	1	P1 (A20J1)	W24 80063 A3093631-13	P2 (A3A5A1J2)		6
14	FIND NO. 2, 14 1		P1 (A3A2J3)	W25 80063 A3093631-14	P2 (A3A5A1J1)		6
15	FIND NO. 2, 13	1	P1 (A3A2J4)	W27 80063 A3093631-15	P2 (A3A5A2J1)		6
16	FIND NO. 2, 18	1	P1 (A3A1J7)	W29 80063 A3093631-16	P2 (A3A5A2J2)		6
17	FIND NO. 2, 16	1	P1 (A3A1J8)	W31 80063 A3093631-17	P2 (A21J1)		6
18	FIND NO. 2, 19	1	P1 (A3A1J9)	W33 80063 A3093631-18	P2 (A23J1)		6

**THIS DOCUMENT HAS BEEN PURCHASED
BY THE GOVERNMENT AND MAY BE REPRO-
DUCED AND USED IN CONNECTION WITH
ANY GOVERNMENT PROCUREMENT OR
MAINTENANCE OPERATION**

SIZE
A

FSCM NO.
80063

DRAWING NO.
A3093631

SCALE NONE **LTR** A **SHEET 10**

A3093631

DASH NO.	A CABLE ASSY	FIGURE NO.	B MARKER 1	C MARKER 2	D MARKER 3	E MARKER 4	NOTES
19	FIND NO. 2, 27	1	P1 (A3A1J3)	W44 80063 A3093631-19	P2 (A15J2)		6
20	FIND NO. 2, 6	1	P1 (A3A1J4)	W45 80063 A3093631-20	P2 (A19J2)		6
21	FIND NO. 2, 5	3	P1 (A3A2J7)	W49 80063 A3093631-21	E1 (A16E1)	E2 (A16E2)	6
22	FIND NO. 2, 22	1	P1 (A3A2J5)	W50 80063 A3093631-22	P2 (A4J1)		6
23							
24							
25	FIND NO. 2, 3	1	P1 (A6J2)	W125 80063 A3093631-25	P2 (A3A7A2J4)		6
26	FIND NO. 2, 20	1	P1 (A3A1J11)	W126 80063 A3093631-26	P2 (A3A7A1J3)		6

0430N	THIS DOCUMENT HAS BEEN PURCHASED BY THE GOVERNMENT AND MAY BE REPRODUCED AND USED IN CONNECTION WITH ANY GOVERNMENT PROCUREMENT OR MAINTENANCE OPERATION	SIZE A	FSCM NO. 80063	DRAWING NO. A3093631
		SCALE NONE	LTR A	SHEET 11

DASH NO.	A CABLE ASSY	FIGURE NO.	B MARKER 1	C MARKER 2	D MARKER 3	E MARKER 4	NOTES
27	FIND NO. 2, 24	1	P1 (A3A6A1J1) VRC-46 OR (A3A7A6J4) VRC-90	W127 80063 A3093631-27	P2 (A3A1J10)		6
28	FIND NO. 2, 21	1	P1 (A6J1)	W128 80063 A3093631-28	P2 (A3A7A2J3) VRC-46 OR (A3A7A3J1) VRC-90		6
29	FIND NO. 2, 26	1	P1 (A3A7A3J21) VRC-46 OR (A3A7A1J1) VRC-90	W129 80063 A3093631-29	P2 (A3A6A3J1)		6

THIS DOCUMENT HAS BEEN PURCHASED BY THE GOVERNMENT AND MAY BE REPRODUCED AND USED IN CONNECTION WITH ANY GOVERNMENT PROCUREMENT OR MAINTENANCE OPERATION	SIZE A	FSCM NO. 80063	DRAWING NO. A3093631
	SCALE NONE	LTR A	SHEET 12

A3093631

NOTES:

1. PREPARED IN ACCORDANCE WITH DOD-STD-100.
2. UNLESS OTHERWISE SPECIFIED, DIMENSIONS ARE IN INCHES.
3. UNLESS OTHERWISE SPECIFIED, TOLERANCES ARE: 2 PLACE DECIMALS $\pm .02$, 3 PLACE DECIMALS $\pm .010$, FRACTIONS $\pm 1/32$, ANGLES ± 1 DEGREE, AND HOLE DIAMETERS $\pm .005$.
4. WORKMANSHIP SHALL BE IN ACCORDANCE WITH MIL-STD-454, REQUIREMENT 9.
5. DIMENSIONAL DATA IS BASED ON AMERICAN NATIONAL STANDARD ANSI Y14.5-1973.
6. MARK PER A3092959, DECAL FABRICATION.
7. PARTIAL REFERENCE DESIGNATIONS ARE SHOWN. FOR COMPLETE REFERENCE DESIGNATION, PREFIX WITH UNIT NUMBER AND SUBASSEMBLY DESIGNATION.
8. CABLE MARKERS MAY BE APPLIED TO CABLES SUCH THAT MARKERS READ EITHER AWAY FROM CABLE END OR TOWARDS CABLE END.

0309N	THIS DOCUMENT HAS BEEN PURCHASED BY THE GOVERNMENT AND MAY BE REPRODUCED AND USED IN CONNECTION WITH ANY GOVERNMENT PROCUREMENT OR MAINTENANCE OPERATION	SIZE	FSCM NO.	DRAWING NO.	
		A	80063	A3093634	
		SCALE	NONE	LTR	D SHEET 3

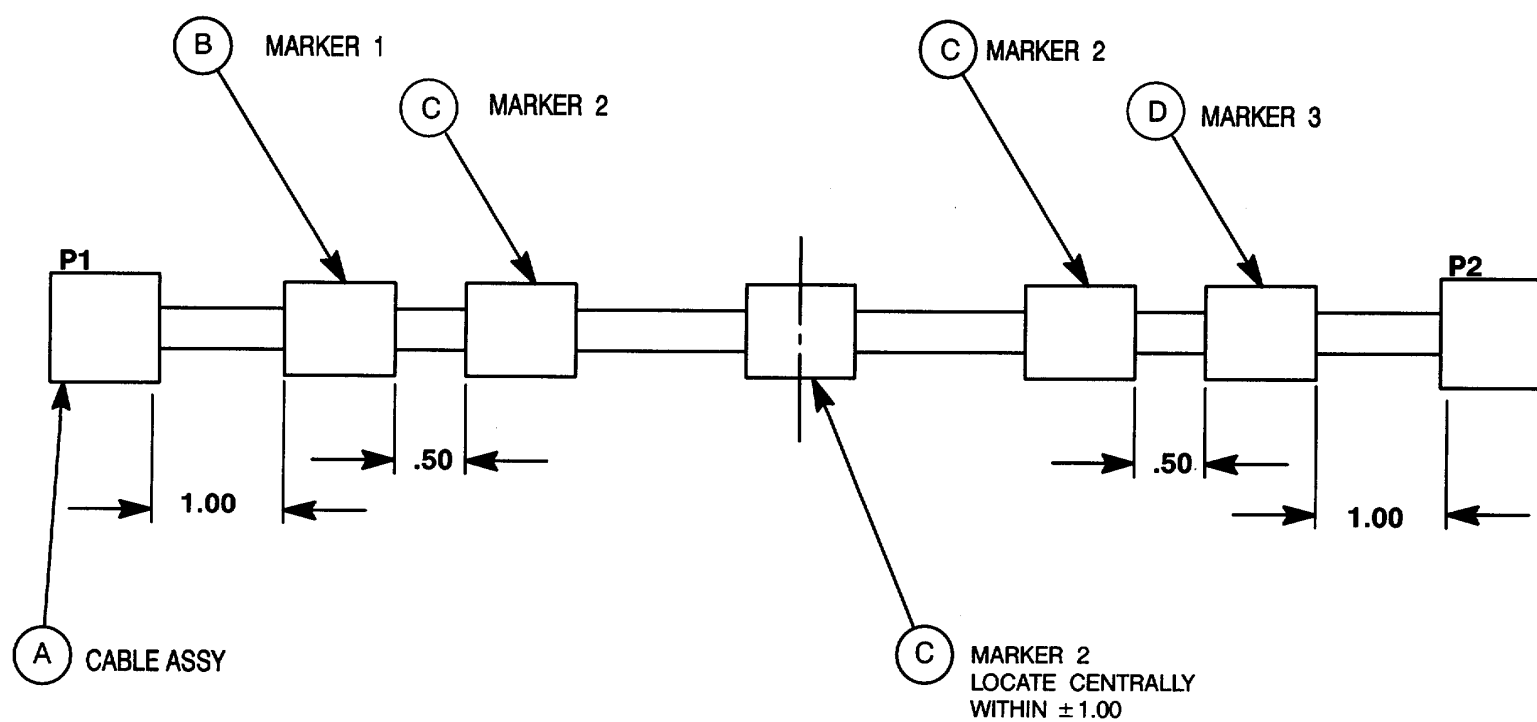

FIGURE 1

THIS DOCUMENT HAS BEEN PURCHASED BY THE GOVERNMENT AND MAY BE REPRODUCED AND USED IN CONNECTION WITH ANY GOVERNMENT PROCUREMENT OR MAINTENANCE OPERATION	SIZE	FSCM NO.	DRAWING NO.	
	A	80063	A3093634	
		SCALE	NONE	LTR A SHEET 4

A3093634

PARTS LIST					
QTY	ITEM	PART NO.	DESCRIPTION	SPEC/STD	FSCM NO.
5	1	A3092925-5	MARKERS		80063
35	2	A3092925-4	MARKERS		80063
1	3	A3092668-1	CABLE ASSEMBLY, RADIO/ENTRY CONTROL		80063
1	4	A3092669-2	CABLE ASSEMBLY, THIN WIRE TRIAX		80063
1	5	A3093616	CABLE ASSEMBLY, ENTRY/ANT CONTROL		80063
1	6	A3093628-1	CABLE ASSEMBLY, RAD/ANT		80063
1	7	A3093628-2	CABLE ASSEMBLY, RAD/ANT		80063
	8				
1	9	A3093645-1	CABLE ASSEMBLY, POWER 28 VDC		80063
	10				
	11				
2	12	A3093089	CABLE ASSEMBLY, POWER, WORKSTATION		80063

0309N	THIS DOCUMENT HAS BEEN PURCHASED BY THE GOVERNMENT AND MAY BE REPRODUCED AND USED IN CONNECTION WITH ANY GOVERNMENT PROCUREMENT OR MAINTENANCE OPERATION	SIZE A	FSCM NO. 80063	DRAWING NO. A3093634
		SCALE NONE	LTR B	SHEET 5

DASH NO.	A CABLE ASSY	FIGURE NO.	B MARKER 1	C MARKER 2	D MARKER 3	E MARKER 4	NOTES
1	FIND NO. 2, 4	1	P1 (A8J5)	W51 80063 A3093634-1	P2 (A9J6)		6
2							
3							
4							
5							
6	FIND NO. 2, 12	1	P1 (J5)	W72 80063 A3093634-6	P2 (A9J4)		6, 12
7	FIND NO. 2, 12		P1 (J4)	W73 80063 A3093634-7	P2 1 (A8J4)		6, 12
8							
9							
10							
11	FIND NO. 2, 3	1	P1 (A6J2)	W125 80063 A3093634-11	P2 (A15A2J4)		6

THIS DOCUMENT HAS BEEN PURCHASED BY THE GOVERNMENT AND MAY BE REPRODUCED AND USED IN CONNECTION WITH ANY GOVERNMENT PROCUREMENT OR MAINTENANCE OPERATION	SIZE A	FSCM NO. 80063	DRAWING NO. A3093634
	SCALE NONE	LTR A	SHEET 6

A3093634

CABLE SET, ADP SHELTER AN/TYQ-30 (Sheets 5 & 6 of 7)

DASH NO.	A CABLE ASSY	FIGURE NO.	B MARKER 1	C MARKER 2	D MARKER 3	E MARKER 4	NOTES
12	FIND NO 1,7	1	P1 (A6J1)	W128 80063 A3093634-12	P2 (A15A2J3) VRC46 OR (A15A3J1) VRC90		6
13	FIND NO 2,9	1	P1 (A15A3J21) VRC46 OR (A15A1J1) VRC90	W129 80063 A3093634-13	P2 (A7A4FL)		6
14							
15							
16							
17							
18	FIND NO 2,6	1	P1 (A6J1)	W140 80063 A3093634-18	P2 (A18J1)		6
19	FIND NO 2,5	1	P1 (A6J2)	W141 80063 A3093634-19	P2 (A18J2)		6

0309N	THIS DOCUMENT HAS BEEN PURCHASED BY THE GOVERNMENT AND MAY BE REPRO- DUCED AND USED IN CONNECTION WITH ANY GOVERNMENT PROCUREMENT OR MAINTENANCE OPERATION	SIZE	FSCM NO.	DRAWING NO.		
		A	80063	A3093634		
		SCALE	NONE	LTR	A	SHEET 7

CABLE SET, ADP SHELTER AN/TYQ-30
(Sheet 7 of 7)

A3093634

NOTES :

1. IDENTIFY PART PER MIL-STD-130, TAG.
 2. WORKMANSHIP SHALL BE IN ACCORDANCE WITH MIL-STD-454, REQUIREMENT 9.
 3. DIMENSIONAL DATA IS BASED ON AMERICAN NATIONAL STANDARD ANSI Y14.5-1973.
 4. P1 CRIMP INSERTION TOOL NO. M81969/8-03, REMOVAL TOOL NO. M81969/8-04, PER MIL-I-81969. P2 CRIMP INSERTION TOOL NO. M81969/8-05, REMOVAL TOOL NO. M81969/8-06 PER MIL-I-81969.
 5. DELETED
 6. EACH CONDUCTOR SHALL BE TESTED FOR CONTINUITY AND CORRECT CONNECTIONS BETWEEN ITS TERMINATIONS, USING A POTENTIAL OF NOT MORE THAN 10 VOLTS. CONTINUITY CHECKS SHALL BE MADE FROM CONNECTOR CONTACT TO CONNECTOR CONTACT USING A CONTINUITY TESTER. CONTINUITY POINTS SHALL BE OBTAINED FROM THE CABLE WIRING DIAGRAM. WHERE SHIELD IS BONDED TO CONNECTOR ON BOTH ENDS, THE SHIELD CONTINUITY SHALL BE CHECKED FROM CONNECTOR SHELL TO CONNECTOR SHELL.
 7. INSULATION RESISTANCE SHALL BE IN ACCORDANCE WITH METHOD 302 OF MIL-STD-202, TEST CONDITION B. THE POTENTIAL SHALL BE APPLIED BETWEEN EACH CONDUCTOR AND THE REMAINING CONDUCTORS CONNECTED TOGETHER AND TO THE SHIELD, AND CONNECTOR. THE INSULATION RESISTANCE OF THE CABLE ASSEMBLY SHALL NOT BE LESS THAN 100 MEGOHMS, EXCEPT THE INSULATION RESISTANCE OF A SHIELDED CONDUCTOR SHALL NOT BE LESS THAN 30 MEGOHMS.
 8. DIELECTRIC WITHSTANDING VOLTAGE. DIELECTRIC STRENGTH SHALL BE PERFORMED IN ACCORDANCE WITH METHOD 301 OF MIL-STD-202. A POTENTIAL OF 500 VOLTS DC SHALL BE APPLIED FOR 30 SECONDS MINIMUM. THE POTENTIAL SHALL BE APPLIED BETWEEN EACH CONDUCTOR AND THE REMAINING CONDUCTORS CONNECTED TOGETHER AND TO THE SHIELD AND CONNECTOR.
 9. PARTIAL REFERENCE DESIGNATIONS ARE SHOWN. FOR COMPLETE REFERENCE DESIGNATION, PREFIX WITH UNIT NUMBER AND SUBASSEMBLY DESIGNATION.
 10. SOLDERING SHALL BE IN ACCORDANCE WITH MIL-STD-454, REQUIREMENT 5.
- ⚠ ALL UNUSED POSITIONS IN CONNECTOR P1 & P2 ARE TO BE FILLED WITH CONTACTS.

12. DELETED
13. QUANTITY SHOWN IS IN INCHES.
- ⚠ 14. TOLERANCE ON CABLE LENGTH SHALL BE +2, -1 INCHES.
- ⚠ 15. DIMENSIONS SHOWN ON CABLE PREPARATION ILLUSTRATION ARE FOR REFERENCE ONLY.
16. VENDOR ITEM - SEE SPECIFICATION CONTROL DRAWING.
- ⚠ 17. J HOOK WIRE SHIELD TO OVERALL SHIELD. PLACE HEAT SHRINK SLEEVING, ITEM 8, OVER J HOOKS.
18. P1 CRIMPING TOOL M22520/2-01 WITH M22520/2-07 TURRET, PER MIL-C-22520.

P2 CRIMPING TOOL M22520/2-01 WITH M22520/2-10 TURRET, PER MIL-C-22520.

3	15	81349	M39029/58-363	CONTACT, CRIMP, PIN	MIL-C-39029/58		
4	14	81349	M39029/56-350	CONTACT, CRIMP, SOCKET	MIL-C-39029/56		
	13						
	12						
1	11	96906	MS27467T9B98P	CONNECTOR, ELECTRICAL, PLUG			
1	10	96906	MS27467T9B44S	CONNECTOR, ELECTRICAL, PLUG			
	9						
2	8	81349	M2305/5-104-0	HEAT SHRINK SLEEVING	MIL-I-23053/5	13	
	7						
	6						
REF	5	80063	A3092728	TEST PROCEDURE/DATA SHEET POWER AND SIGNAL CABLE TEST			
	4						
2	3	80063	A3093589-69	BACKSHELL, EMI/RFI			16
184	2	80063	A3093563-2	CABLE, ELECTRICAL, SPECIAL PURPOSE			13 , 16
	1						
QTY REQD	FIND NO.	FSCM NO.	PART NUMBER OR IDENTIFYING NO.	NOMENCLATURE OR DESCRIPTION	SPEC/STD	SHEET NO.	NOTE
PARTS LIST							

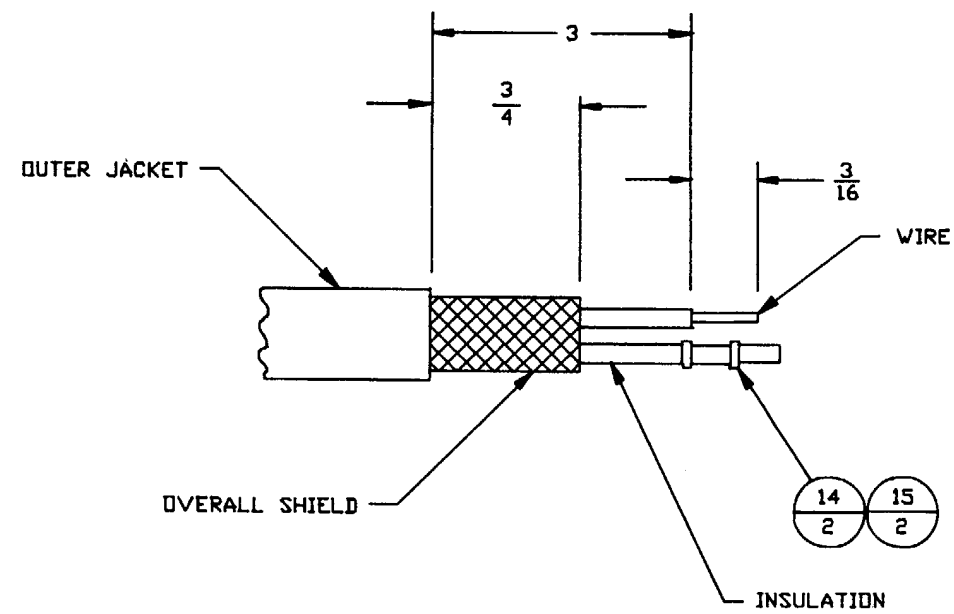
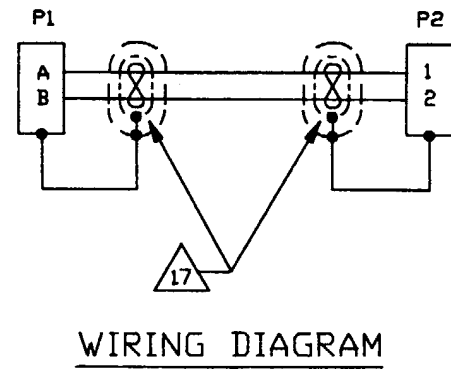
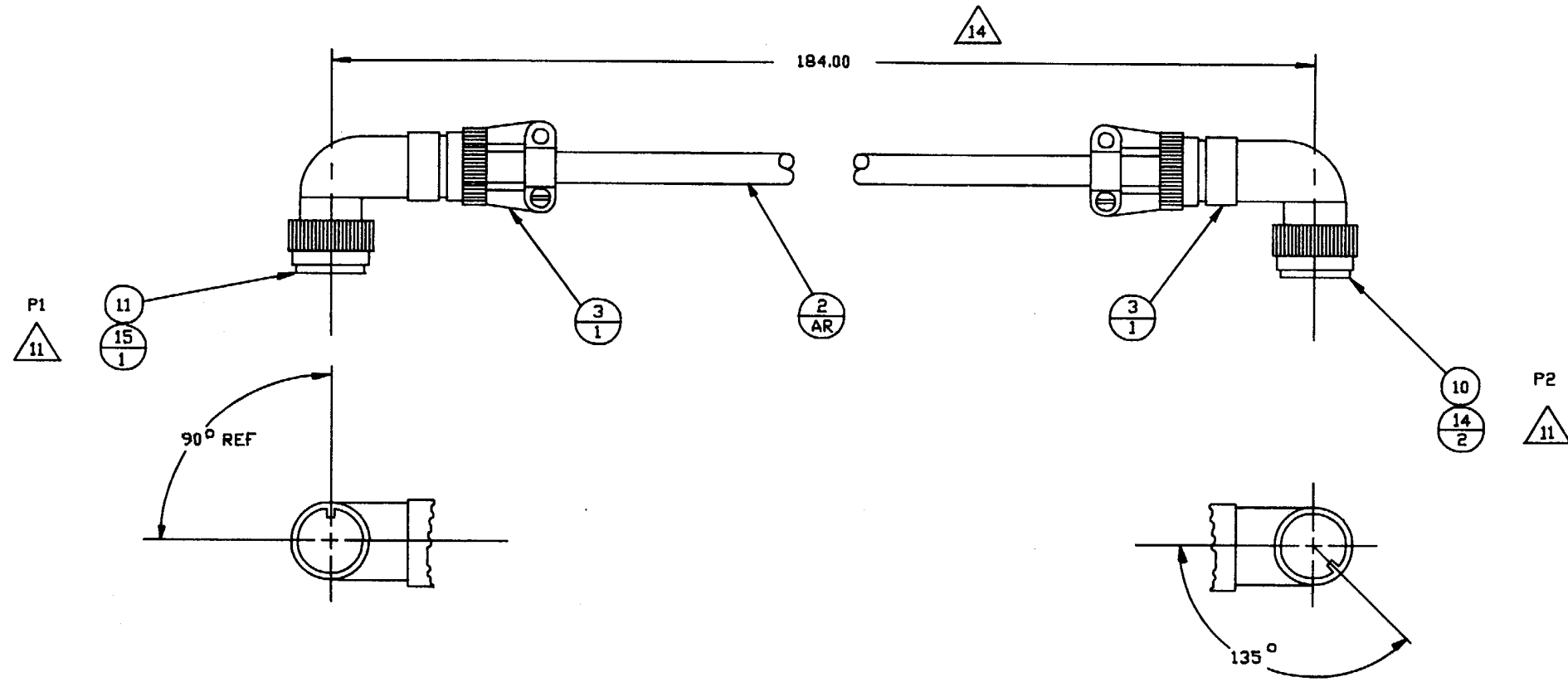

△15 CABLE PREPARATION
SCALE : NONE
BOTH ENDS

Cable Assembly, Audio/Posts
(Sheet 2 of 2)

NOTE: DATA MARKED WITH AN ASTERISK (*) IS PECULIAR TO A PRIOR MANUFACTURER.
IT DOES NOT TAKE PRECEDENCE OVER ANY OTHER DATA ON THIS DRAWING, AND
IS NOT CONTRACTUALLY BINDING ON EITHER THE CONTRACTOR OR THE GOVERNMENT.

THIS DOCUMENT HAS BEEN PURCHASED BY THE GOVERNMENT AND MAY BE REPRODUCED AND USED IN CONNECTION WITH ANY GOVERNMENT PROCUREMENT OR MAINTENANCE OPERATION.

REVISIONS					
EFF	LTR	NO.	DESCRIPTION	DATE	APPROVED
ALL	A		INC ECN 93278	88-06-23	LC
ALL	B		INC ECN 92864	88-07-20	LC SK
ALL	C		INC ECN 97030	88-08-03	DD CP
ALL	D		INC ECN 102640	89-02-22	DD TB
	E		INC ECN 109723, EFF: 89-06-30	89-08-01	AH PEF
	F		INC ECN 135054	91-03-20	LC BM

REV SHEET																				
REV STATUS OF SHEETS	REV SHEET	F	F	D	A	B	A	A												
		1	2	3	4	5	6	7												

1. PREPARED IN ACCORDANCE WITH DOD-STD-100. 2. UNLESS OTHERWISE SPECIFIED, DIMENSIONS ARE IN INCHES.	ELECTROSPACE SYSTEMS, INC. DAAB07-86-C-J008			U.S. ARMY COMMUNICATIONS - ELECTRONIC COMMAND FORT MONMOUTH, NEW JERSEY 07703		
	APVD	M. MARTIN	88-02-09	DRAWING TITLE		
	ENGR	C. PYBUS	88-02-08	CABLE SET, SHELTER, OPN		
	ENGR	L. HAWES	88-02-08	SIZE	FSCM NO.	DRAWING NO.
	CHECK	L. FETZER	88-02-12	A	80063	A3093637
	DRAWN	L. CHATELAIN	88-02-12			
SEE SHEET 2	REV	P. PAO (ED-MX)	10/9/92	SCALE	NONE	F SHEET 1 OF 7
NEXT ASSY USED ON	APVD	R. RICCELLI (ED-MX)	R			
APPLICATION	DATE	11-19-92				

DASH NO	NEXT ASSEMBLY	USED ON	QTY	DASH NO	NEXT ASSEMBLY	USED ON	QTY
5	A3092693	DLA3092692	1				
6	A3092693	DLA3092692	1				
7	A3092693	DLA3092692	1				
8	A3092693	DLA3092692	1				
9	A3092693	DLA3092692	1				
10	A3092693	DLA3092692	1				
11	A3092693	DLA3092692	1				
17	A3092693	DLA3092692	1				
18	A3092693	DLA3092692	1				

THIS DOCUMENT HAS BEEN PURCHASED BY THE GOVERNMENT AND MAY BE REPRODUCED AND USED IN CONNECTION WITH ANY GOVERNMENT PROCUREMENT OR MAINTENANCE OPERATION	SIZE	FSCM NO.	DRAWING NO.	
	A	80063	A3093637	
SCALE	NONE	LTR	F	SHEET 2

NOTES:

1. PREPARED IN ACCORDANCE WITH DOD-STD-100.
2. UNLESS OTHERWISE SPECIFIED, DIMENSIONS ARE IN INCHES.
3. UNLESS OTHERWISE SPECIFIED, TOLERANCES ARE: 2 PLACE DECIMALS ± .02, 3 PLACE DECIMALS ± .010, FRACTIONS ±1/32, ANGLES ± 1 DEGREE, AND HOLE DIAMETERS ±.005.
4. WORKMANSHIP SHALL BE IN ACCORDANCE WITH MIL-STD-454, REQUIREMENT 9.
5. DIMENSIONAL DATA IS BASED ON AMERICAN NATIONAL STANDARD ANSI Y14.5-1973.
6. MARK PER A3092959, DECAL FABRICATION.
7. PARTIAL REFERENCE DESIGNATIONS ARE SHOWN. FOR COMPLETE REFERENCE DESIGNATION, PREFIX WITH UNIT NUMBER AND SUBASSEMBLY DESIGNATION.
8. COMPLETE PART NUMBER SHALL INCLUDE APPLICABLE DASH NUMBER.
9. CABLE MARKERS MAY BE APPLIED TO CABLES SUCH THAT MARKERS READ EITHER AWAY FROM CABLE END OR TOWARDS CABLE END.

0431N	THIS DOCUMENT HAS BEEN PURCHASED BY THE GOVERNMENT AND MAY BE REPRODUCED AND USED IN CONNECTION WITH ANY GOVERNMENT PROCUREMENT OR MAINTENANCE OPERATION	SIZE	FSCM NO.	DRAWING NO.
		A	80063	DRAWING NO.
		SCALE	NONE	A3093637
				SHEET 3

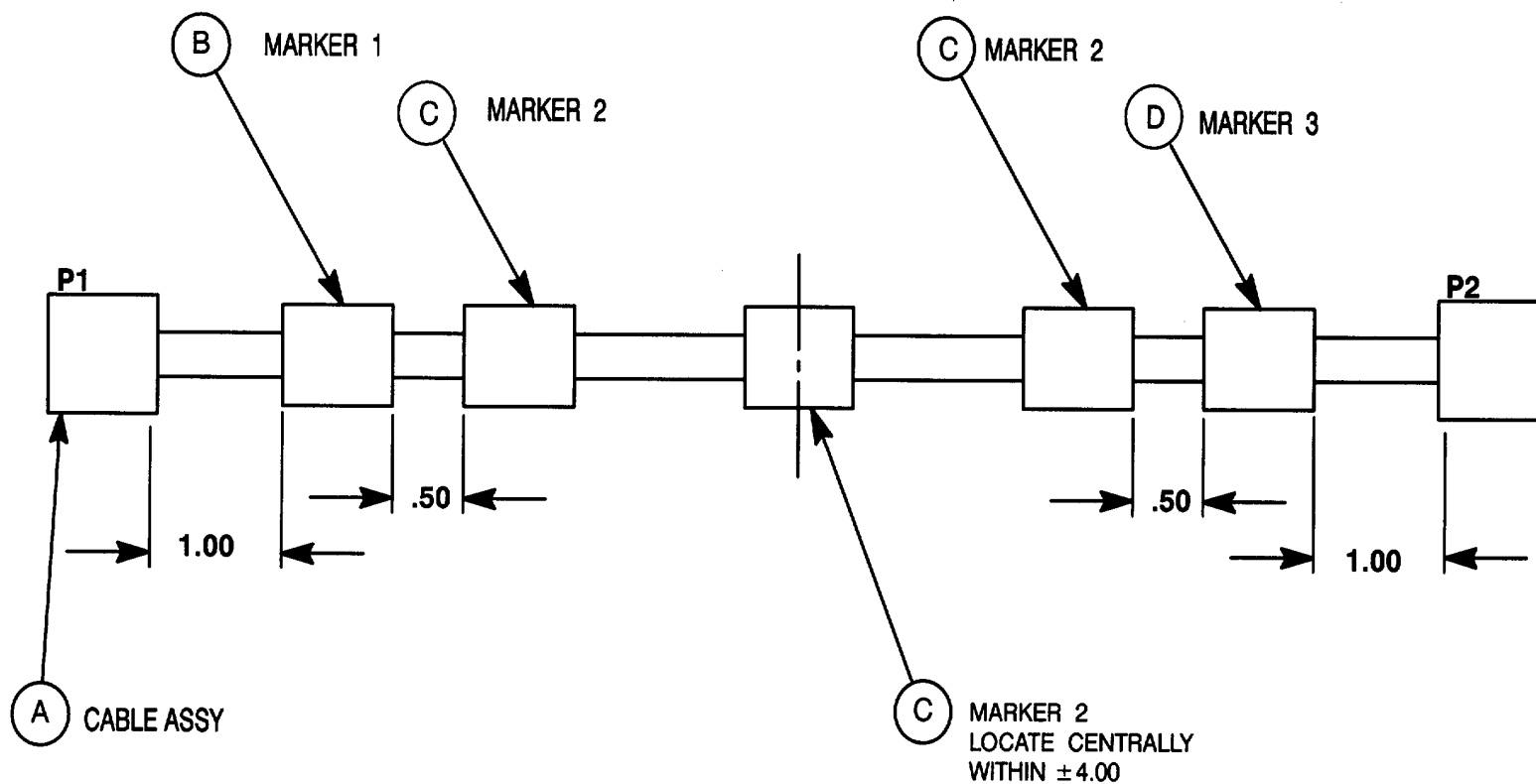

FIGURE 1

THIS DOCUMENT HAS BEEN PURCHASED BY THE GOVERNMENT AND MAY BE REPRODUCED AND USED IN CONNECTION WITH ANY GOVERNMENT PROCUREMENT OR MAINTENANCE OPERATION	SIZE	FSCM NO.	DRAWING NO.
	A	80063	A3093637
	SCALE	NONE	LTR A
			SHEET 4

A3093637

CABLE SET,
SHELTER, OPN
(Sheets 3 & 4 of 7)

PARTS LIST

TM 11-5895-1392-34-2

QTY	ITEM	PART NO.	DESCRIPTION	SPEC/STD	FSCM NO.
	1				
45	2	A3092925-4	MARKERS		80063
1	3	A3092669-8	CABLE ASSEMBLY, THIN WIRE TRIAX		80063
1	4	A3093616	CABLE ASSEMBLY, ENTRY/ANT CONTROL		80063
1	5	A3093628-1	CABLE ASSEMBLY, RAD/ANT		80063
	6				
	7				
	8				
4	9	A3093089	CABLE ASSEMBLY, POWER, WORKSTATION		80063
	10				
	11				
1	12	A3092669-9	CABLE ASSEMBLY, THIN WIRE TRIAX		80063
1	13	A3092669-10	CABLE ASSEMBLY, THIN WIRE TRIAX		80063

0431N	THIS DOCUMENT HAS BEEN PURCHASED BY THE GOVERNMENT AND MAY BE REPRODUCED AND USED IN CONNECTION WITH ANY GOVERNMENT PROCUREMENT OR MAINTENANCE OPERATION	SIZE	FSCM NO.	DRAWING NO.	
		A	80063	A3093637	
		SCALE	NONE	LTR	B SHEET
					5

DASH NO.	A CABLE ASSY	FIGURE NO.	B MARKER 1	C MARKER 2	D MARKER 3	E MARKER 4	NOTES
1							
2							
3							
4							
5	FIND NO. 2,3	1	P1 (A7J6)	W13 80063 A3093637-5	P2 (A8J5)		6
6	FIND NO. 2,12	1	P1 (A8J6)	W14 80063 A3093637-6	P2 (A15J5)		6
7	FIND NO. 2,13	1	P1 (A15J6)	W15 80063 A3093637-7	P2 (A19J5)		6
8	FIND NO. 2,9	1	P1 (J2)	W18 80063 A3093637-8	P2 (A7J4)		6
9	FIND NO. 2,9	1	P1 (J6)	W20 80063 A3093637-9	P2 (A8J4)		6

THIS DOCUMENT HAS BEEN PURCHASED BY THE GOVERNMENT AND MAY BE REPRODUCED AND USED IN CONNECTION WITH ANY GOVERNMENT PROCUREMENT OR MAINTENANCE OPERATION	SIZE	FSCM NO.	DRAWING NO.		
	A	80063	A3093637		
		SCALE	NONE	LTR	A SHEET
					6

CABLE SET,
SHELTER, OPN
(Sheets 5 & 6 of 7)

DASH NO.	A CABLE ASSY	FIGURE NO.	B MARKER 1	C MARKER 2	D MARKER 3	E MARKER 4	NOTES
10	FIND NO. 2,9	1	P1 (J12)	W21 80063 A3093637-10	P2 (A15J4)		6
11	FIND NO. 2,9	1	P1 (J9)	W23 80063 A3093637-11	P2 (A19J4)		6
12							
13							
14							
15							
16							
17	FIND NO. 2,5	1	P1 (A6J1)	W140 80063 A3093637-17	P2 (A18J1)		6
18	FIND NO. 2,4	1	P1 (A6J2)	W141 80063 A3093637-18	P2 (A18J2)		6

0431N	THIS DOCUMENT HAS BEEN PURCHASED BY THE GOVERNMENT AND MAY BE REPRODUCED AND USED IN CONNECTION WITH ANY GOVERNMENT PROCUREMENT OR MAINTENANCE OPERATION	SIZE	FSCM NO.	DRAWING NO.
		A	80063	
		SCALE	NONE	LIMIT A
				A3093637 SHEET 7

CABLE SET, SHELTER, OPN
(Sheet 7 of 7)

A3093637

NOTES :

1. IDENTIFY PART PER MIL-STD-130, TAG.
2. WORKMANSHIP SHALL BE IN ACCORDANCE WITH MIL-STD-454, REQUIREMENT 9.
3. DIMENSIONAL DATA IS BASED ON AMERICAN NATIONAL STANDARD ANSI Y14.5-1973.
4. CRIMP INSERTION / REMOVAL TOOL NO. FOR P1 M81969/17-03, FOR P2 M81969/1-02 PER MIL-I-81969.
5. CRIMPING TOOL FOR P1 M22520/1-01, WITH M22520/1-02 TURRET; FOR P2 M22520/2-01, WITH M22520/2-08 TURRET PER MIL-C-22520.
6. EACH CONDUCTOR SHALL BE TESTED FOR CONTINUITY AND CORRECT CONNECTIONS BETWEEN ITS TERMINATIONS, USING A POTENTIAL OF NOT MORE THAN 10 VOLTS. CONTINUITY CHECKS SHALL BE MADE FROM CONNECTOR CONTACT TO CONNECTOR CONTACT USING A CONTINUITY TESTER. CONTINUITY POINTS SHALL BE OBTAINED FROM THE CABLE WIRING DIAGRAM. WHERE SHIELD IS BONDED TO CONNECTOR ON BOTH ENDS, THE SHIELD CONTINUITY SHALL BE CHECKED FROM CONNECTOR SHELL TO CONNECTOR SHELL.
7. INSULATION RESISTANCE SHALL BE IN ACCORDANCE WITH METHOD 302 OF MIL-STD-202, TEST CONDITION B. THE POTENTIAL SHALL BE APPLIED BETWEEN EACH CONDUCTOR AND THE REMAINING CONDUCTORS CONNECTED TOGETHER AND TO THE SHIELD, AND CONNECTOR. THE INSULATION RESISTANCE OF THE CABLE ASSEMBLY SHALL NOT BE LESS THAN 100 MEGOHMS, EXCEPT THE INSULATION RESISTANCE OF A SHIELDED CONDUCTOR SHALL NOT BE LESS THAN 30 MEGOHMS.
8. DIELECTRIC WITHSTAND VOLTAGE. DIELECTRIC STRENGTH SHALL BE PERFORMED IN ACCORDANCE WITH METHOD 301 OF MIL-STD-202. A POTENTIAL OF 500 VOLTS DC SHALL BE APPLIED FOR 30 SECONDS MINIMUM. THE POTENTIAL SHALL BE APPLIED BETWEEN EACH CONDUCTOR AND THE REMAINING CONDUCTORS CONNECTED TOGETHER AND TO THE SHIELD AND CONNECTOR.
9. PARTIAL REFERENCE DESIGNATION ARE SHOWN. FOR COMPLETE REFERENCE DESIGNATION, PREFIX WITH UNIT NUMBER AND SUBASSEMBLY DESIGNATION.

△ ALL UNUSED POSITIONS IN CONNECTORS P1 & P2 ARE TO BE FILLED WITH CONTACTS.

11. QUANTITY SHOWN IS IN INCHES.

△ TOLERANCE ON CABLE LENGTH SHALL BE +2,-1 INCHES.

- △ DIMENSIONS SHOWN ON CABLE PREPARATION ILLUSTRATION ARE FOR REFERENCE ONLY.
14. VENDOR ITEM - SEE SPECIFICATION CONTROL DRAWING.
 15. COMPLETE PART NUMBER FOR THIS ASSEMBLY SHALL INCLUDE APPLICABLE DASH NUMBER INDICATED IN QUANTITY REQUIRED COLUMN.

1	1	14	96906	MS3126F14-18S	CONNECTOR, ELECTRICAL, PLUG			
25	25	13	81349	M39029/63-368	CONTACT, CRIMP, SOCKET	MIL-C-39029/63		
18	18	12	81349	M39029/32-259	CONTACT, CRIMP, SOCKET	MIL-C-39029/32		
1	1	11	81349	M24308/2-3	CONNECTOR, ELECTRICAL, PLUG	MIL-C-24308/2		
		10						
		9						
		8						
		7						
		6						
REF	REF	5	80063	A3092728	TEST PROCEDURE/DATA SHEET POWER AND SIGNAL CABLE TEST			
		4						
1	1	3	80063	A3093589-6	BACKSHELL, EMI/RFI			14
1	1	2	80063	A3093576-9	BACKSHELL, EMI/RFI			14
127	98	1	80063	A3093562-26	CABLE, ELECTRICAL, SPECIAL PURPOSE			11, 14
QTY REQD	QTY REQD	FIND NO.	FSCM NO.	PART NUMBER OR IDENTIFYING NO.	NOMENCLATURE OR DESCRIPTION	SPEC/STD	SHEET NO.	NOTE
-2	-1			PARTS LIST				

Cable Assembly, CP/Patch (Alarm)
(Sheet 1 of 2)

CHART A	
DASH NO.	DIM A
1	98.00
2	127.00

CHART A	
END TYPE	DIM B
P1	1.25 REF
P2	2.25 REF

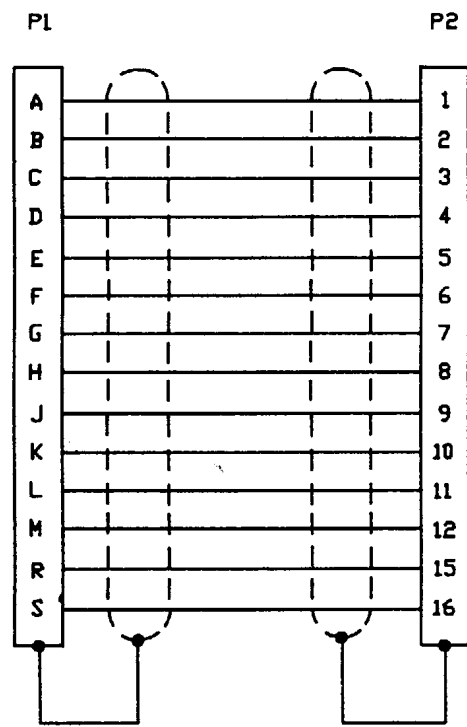

WIRING DIAGRAM

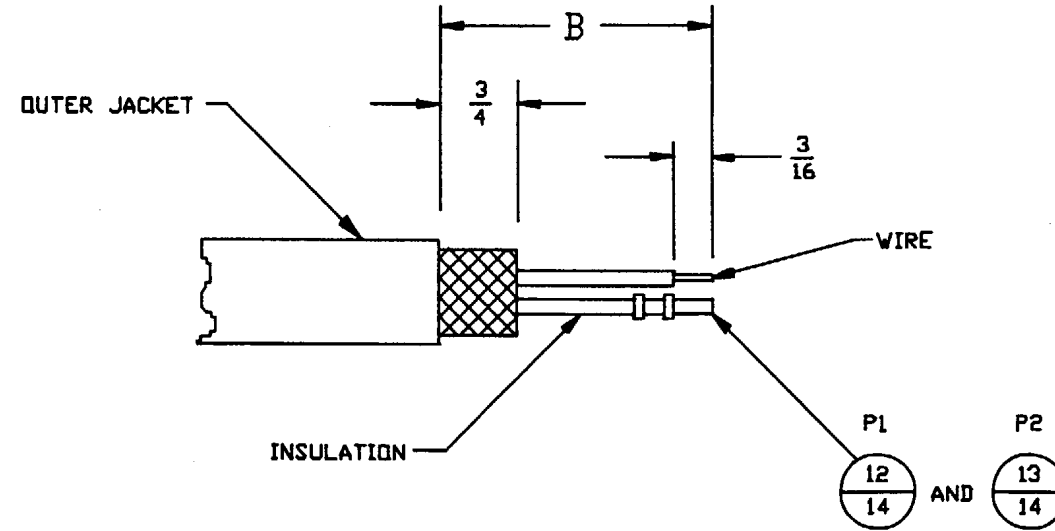
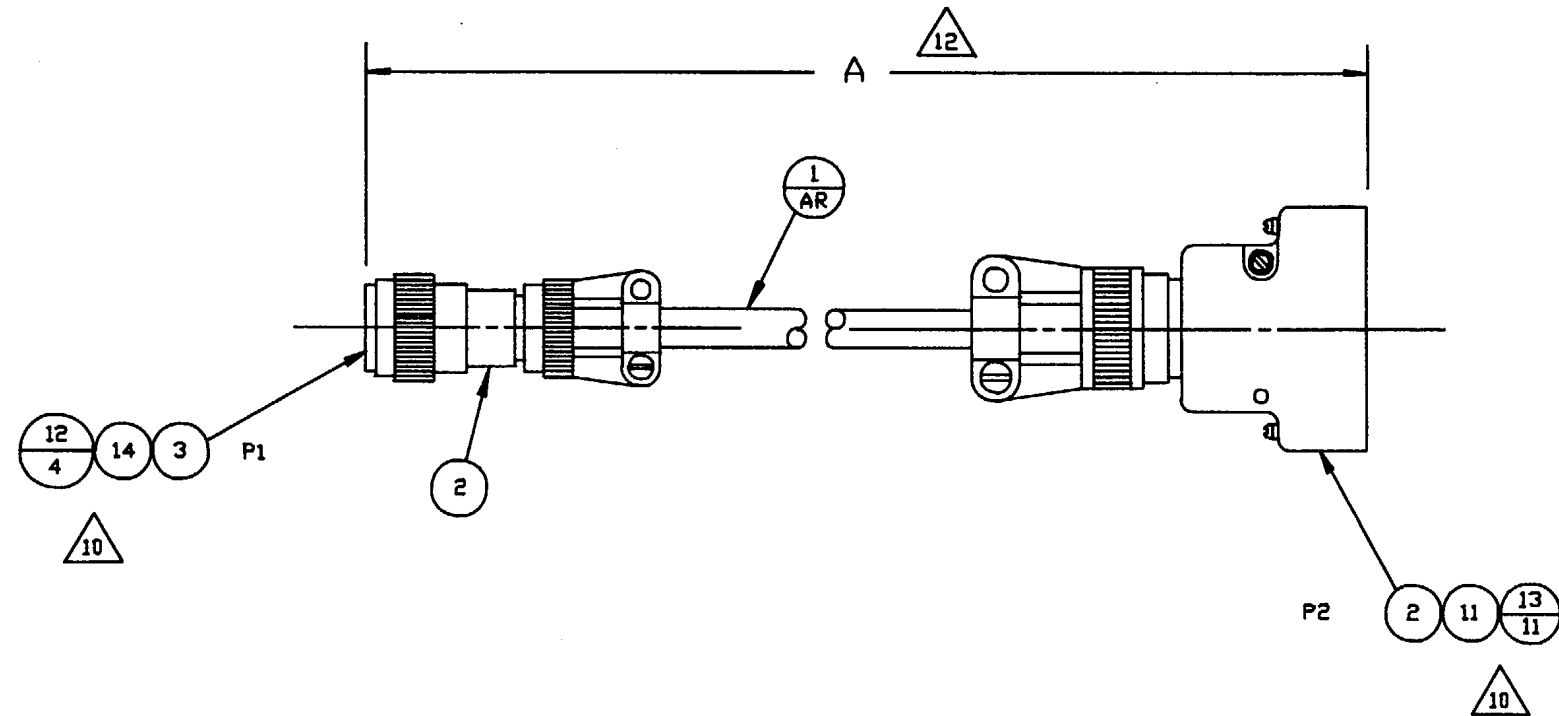

CABLE PREPARATION 13

BOTH ENDS

Cable Assembly, CP/Patch (Alarm)
(Sheet 2 of 2)

NOTES :

1. IDENTIFY PART PER MIL-STD-130, TAG.
2. WORKMANSHIP SHALL BE IN ACCORDANCE WITH MIL-STD-454, REQUIREMENT 9.
3. DIMENSIONAL DATA IS BASED ON AMERICAN NATIONAL STANDARD ANSI Y14.5-1973.
4. CRIMP INSERTION TOOL NO. FOR P2 M81969/17-03, REMOVAL TOOL NO. M81969/19-07, PER MIL-I-81969.
5. CRIMPING TOOL FOR P2 M22520/1-01 WITH M22520/1-02 TURRET, PER MIL-C-22520.
6. EACH CONDUCTOR SHALL BE TESTED FOR CONTINUITY AND CORRECT CONNECTIONS BETWEEN ITS TERMINATIONS, USING A POTENTIAL OF NOT MORE THAN 10 VOLTS. CONTINUITY CHECKS SHALL BE MADE FROM CONNECTOR CONTACT TO CONNECTOR CONTACT USING A CONTINUITY TESTER. CONTINUITY POINTS SHALL BE OBTAINED FROM THE CABLE WIRING DIAGRAM. WHERE SHIELD IS BONDED TO CONNECTOR ON BOTH ENDS, THE SHIELD CONTINUITY SHALL BE CHECKED FROM CONNECTOR SHELL TO CONNECTOR SHELL.
7. INSULATION RESISTANCE SHALL BE IN ACCORDANCE WITH METHOD 302 OF MIL-STD-202, TEST CONDITION B. THE POTENTIAL SHALL BE APPLIED BETWEEN EACH CONDUCTOR AND THE REMAINING CONDUCTORS CONNECTED TOGETHER AND TO THE SHIELD, AND CONNECTOR. THE INSULATION RESISTANCE OF THE CABLE ASSEMBLY SHALL NOT BE LESS THAN 100 MEGOHMS. EXCEPT THE INSULATION RESISTANCE OF A SHIELDED CONDUCTOR SHALL NOT BE LESS THAN 30 MEGOHMS.
8. DIELECTRIC WITHSTAND VOLTAGE. DIELECTRIC STRENGTH SHALL BE PERFORMED IN ACCORDANCE WITH METHOD 301 OF MIL-STD-202. A POTENTIAL OF 500 VOLTS DC SHALL BE APPLIED FOR 30 SECONDS MINIMUM. THE POTENTIAL SHALL BE APPLIED BETWEEN EACH CONDUCTOR AND THE REMAINING CONDUCTORS CONNECTED TOGETHER AND TO THE SHIELD AND CONNECTOR.
9. PARTIAL REFERENCE DESIGNATION ARE SHOWN. FOR COMPLETE REFERENCE DESIGNATION, PREFIX WITH UNIT NUMBER AND SUBASSEMBLY DESIGNATION.

10. COMPLETE PART NUMBER SHALL INCLUDE APPLICABLE DASH NUMBER AS INDICATED IN THE QUANTITY REQUIRED COLUMN.
11. QUANTITY SHOWN IS IN INCHES.
12. TOLERANCE ON CABLE LENGTH SHALL BE +2, -1 INCHES.
13. DELETED.
- △14 ALL SHIELDS MUST TERMINATE INSIDE OF EMI BACKSHELL.
- △15 DISCARD ITEMS INDICATED PRIOR TO FINAL ASSEMBLY PER DETAIL NO. 1.
- △16 DIMENSIONS SHOWN ON CABLE PREPARATION ILLUSTRATION ILLUSTRATION ARE FOR REFERENCE ONLY.
- △17 J HOOK SHIELDS TOGETHER. PLACE HEAT SHRINK SLEEVING, ITEM 8, OVER J HOOKS.
18. VENDOR ITEM, SEE SPECIFICATION CONTROL DRAWING.

QTY REQD	QTY REQD	FIND NO.	FSCM NO.	PART NUMBER OR IDENTIFYING NO.	NOMENCLATURE OR DESCRIPTION	SPEC/STD	SHEET NO.	NOTE	
		15							
1	1	14	81349	GC329	CONNECTOR, AUDIO	MIL-C-55116			
		13							
6	6	12	81349	M39029/32-259	CONTACT, CRIMP, SOCKET	MIL-C-39029/32			
1	1	11	96906	MS3126F10-6S	CONNECTOR, ELECTRICAL, RECEPTACLE				
		10							
		9							
3	3	8	81349	M23053/5-104-0	HEAT SHRINK SLEEVING	MIL-I-23053/5			
		7							
		6							
REF	REF	5	80063	A3092728	TEST PROCEDURE/DATA SHEET POWER AND SIGNAL CABLE TEST				
		4							
1	1	3	80063	A3093086-3	BACKSHELL, EMI/RFI			18	
1	1	2	80063	A3092984-2	BACKSHELL, EMI/RFI			18	
88	498	1	80063	A3093563-2	CABLE, ELECTRICAL, SPECIAL PURPOSE			11, 18	
QTY REQD	QTY REQD	FIND NO.	FSCM NO.	PART NUMBER OR IDENTIFYING NO.	NOMENCLATURE OR DESCRIPTION	SPEC/STD	SHEET NO.	NOTE	
-2	-1	PARTS LIST							

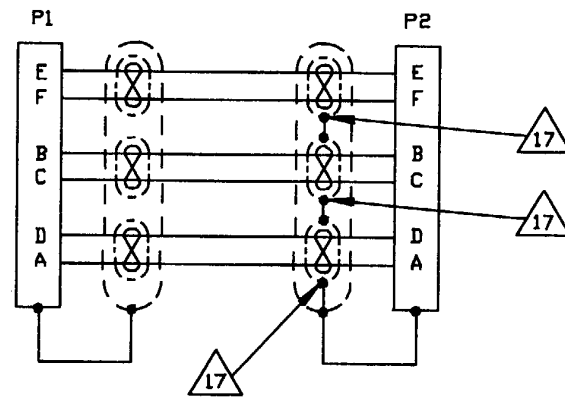

WIRING DIAGRAM

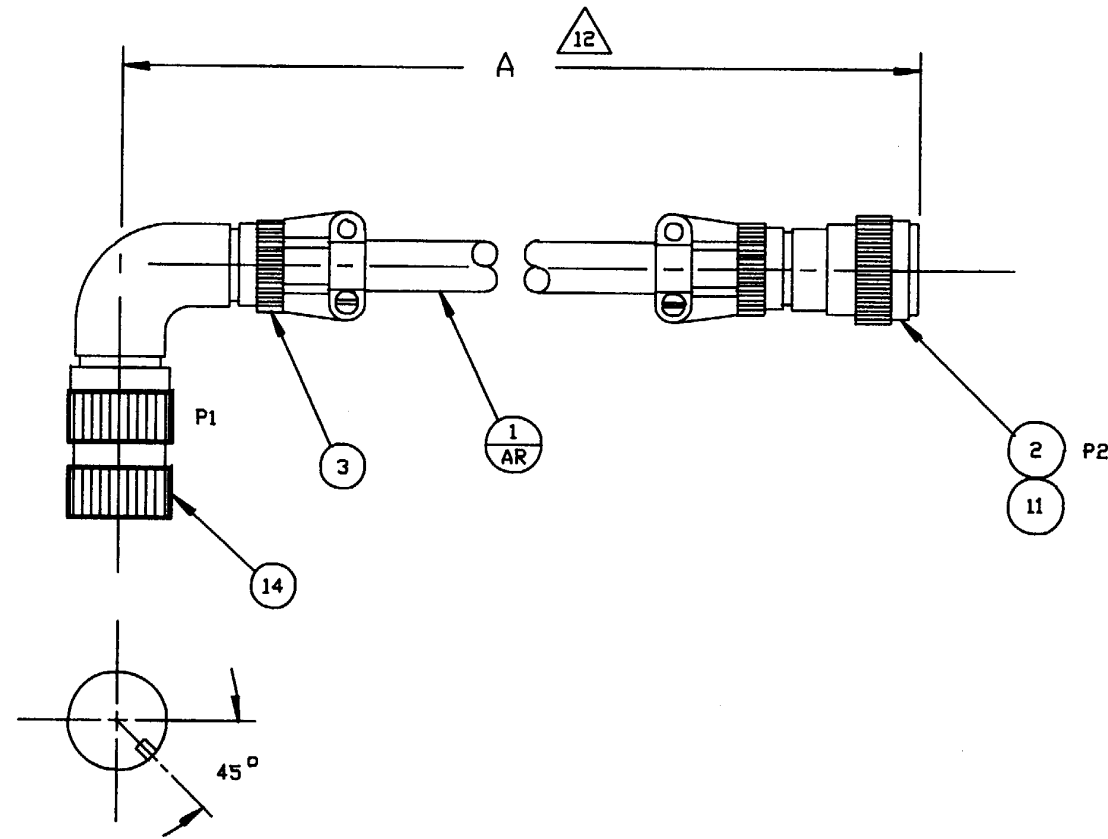
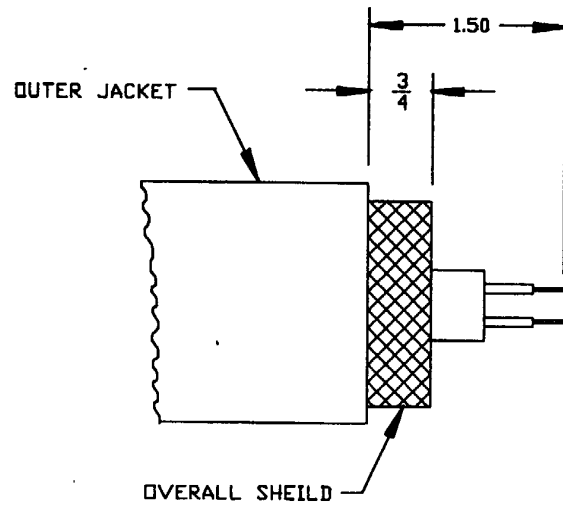
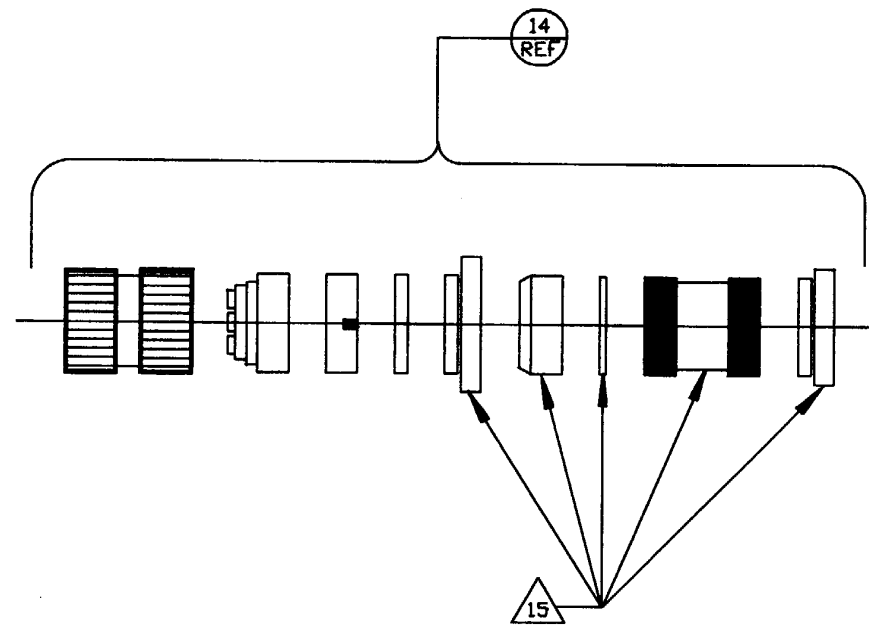

CHART A	
DASH NO.	DIMENSION A
1	498
2	88



14 16 CABLE PREPARATION

SCALE : NONE
P1



DETAIL NO. 1

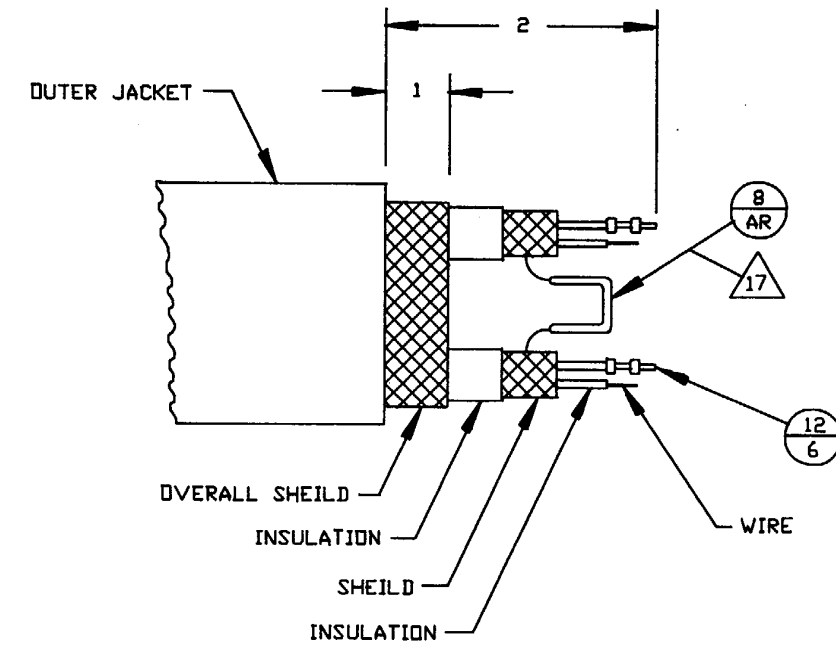

14 16 CABLE PREPARATION

SCALE : NONE
P2



Cable Assembly, Radio/Patch
(Sheet 2 of 2)

NOTES :

1. IDENTIFY PART PER MIL-STD-130, TAG.
2. WORKMANSHIP SHALL BE IN ACCORDANCE WITH MIL-STD-454, REQUIREMENT 9.
3. DIMENSIONAL DATA IS BASED ON AMERICAN NATIONAL STANDARD ANSI Y14.5-1973.
4. CRIMP INSERTION TOOL NO. M81969/17-03, REMOVAL TOOL NO. M81969/19-07, PER MIL-I-81969.
5. CRIMPING TOOL NO. M22520/1-01 WITH M22520/1-02 TURRET, PER MIL-C-22520.
6. EACH CONDUCTOR SHALL BE TESTED FOR CONTINUITY AND CORRECT CONNECTIONS BETWEEN ITS TERMINATIONS, USING A POTENTIAL OF NOT MORE THAN 10 VOLTS. CONTINUITY CHECKS SHALL BE MADE FROM CONNECTOR CONTACT TO CONNECTOR CONTACT USING A CONTINUITY TESTER. CONTINUITY POINTS SHALL BE OBTAINED FROM THE CABLE WIRING DIAGRAM. WHERE SHIELD IS BONDED TO CONNECTOR ON BOTH ENDS, THE SHIELD CONTINUITY SHALL BE CHECKED FROM CONNECTOR SHELL TO CONNECTOR SHELL.
7. INSULATION RESISTANCE SHALL BE IN ACCORDANCE WITH METHOD 302 OF MIL-STD-202, TEST CONDITION B. THE POTENTIAL SHALL BE APPLIED BETWEEN EACH CONDUCTOR AND THE REMAINING CONDUCTORS CONNECTED TOGETHER AND TO THE SHIELD, AND CONNECTOR. THE INSULATION RESISTANCE OF THE CABLE ASSEMBLY SHALL NOT BE LESS THAN 100 MEGOHMS. EXCEPT THE INSULATION RESISTANCE OF A SHIELDED CONDUCTOR SHALL NOT BE LESS THAN 30 MEGOHMS.
8. DIELECTRIC WITHSTAND VOLTAGE. DIELECTRIC STRENGTH SHALL BE PERFORMED IN ACCORDANCE WITH METHOD 301 OF MIL-STD-202. A POTENTIAL OF 500 VOLTS DC SHALL BE APPLIED FOR 30 SECONDS MINIMUM. THE POTENTIAL SHALL BE APPLIED BETWEEN EACH CONDUCTOR AND THE REMAINING CONDUCTORS CONNECTED TOGETHER AND TO THE SHIELD AND CONNECTOR.
9. PARTIAL REFERENCE DESIGNATION ARE SHOWN. FOR COMPLETE REFERENCE DESIGNATION, PREFIX WITH UNIT NUMBER AND SUBASSEMBLY DESIGNATION.

 LOCATE MARKER B CENTRALLY, ± 6 INCHES.

 ALL UNUSED POSITIONS IN CONNECTOR P1 AND P2 ARE TO BE FILLED WITH CONTACTS.

12. QUANTITY SHOWN IS IN INCHES.
-  TOLERANCE ON CABLE LENGTH SHALL BE +6,-2 INCHES.
-  DIMENSIONS SHOWN IN CABLE PREPARATION ILLUSTRATION ARE FOR REFERENCE ONLY.
15. VENDOR ITEM-SEE SPECIFICATION CONTROL DRAWING.
-  MARK PER A3092959.

2	18	80063	SM-A-838108-8	ADAPTOR			15
	17						
1	16	96906	MS27502B23CL	DUST, CAP			
1	15	96906	MS27501B23CL	DUST, CAP			
	14						
1	13	96906	MS27468T23853P	CONNECTOR, ELECTRICAL, RECEPTACLE			
1	12	96906	MS27467T23853S	CONNECTOR, ELECTRICAL, PLUG			
	11						
53	10	81349	MS9029/58-363	CONTACT, CRIMP, PIN	MIL-C-39029/58		
53	9	81349	M39029/56-351	CONTACT, CRIMP, SOCKET	MIL-C-39029/56		
	8						
	7						
	6						
REF	5	80063	A3092728	TEST PROCEDURE/DATA SHEET POWER AND SIGNAL CABLE TEST			
	4						
	3						
600	2	81349	WM-130 A/G	CABLE ASSY, TELEPHONE	MIL-C-55036		12
3	1	80063	A3092925-5	CABLE MARKER			15
QTY REQD	FIND NO.	FSCM NO.	PART NUMBER OR IDENTIFYING NO.	NOMENCLATURE OR DESCRIPTION	SPEC/STD	SHEET NO.	NOTE
PARTS LIST							

Cable Assembly, 26 Pair Extension
(Sheet 1 of 3)

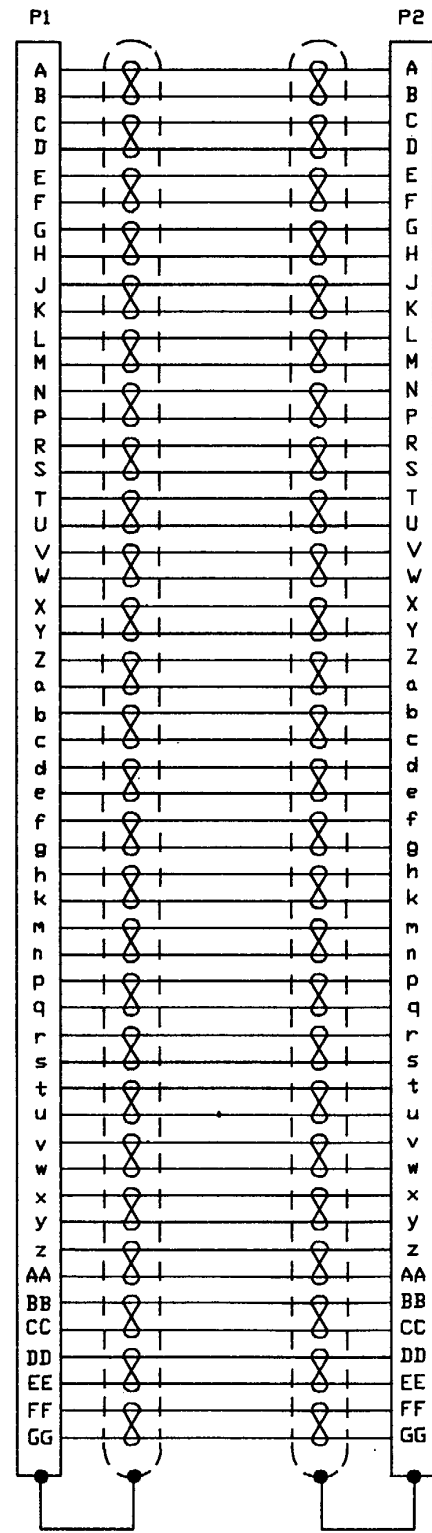

WIRING DIAGRAM

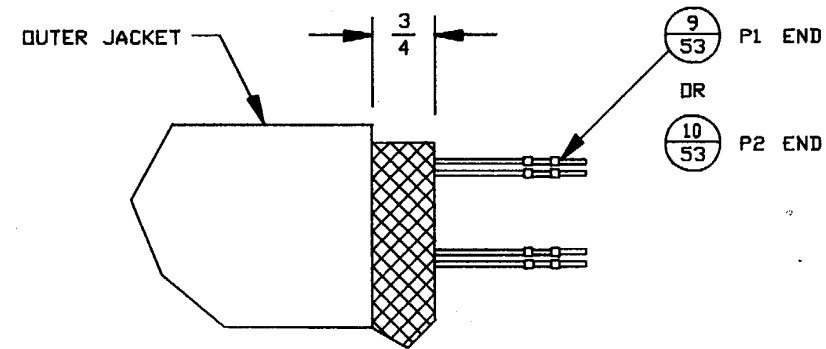
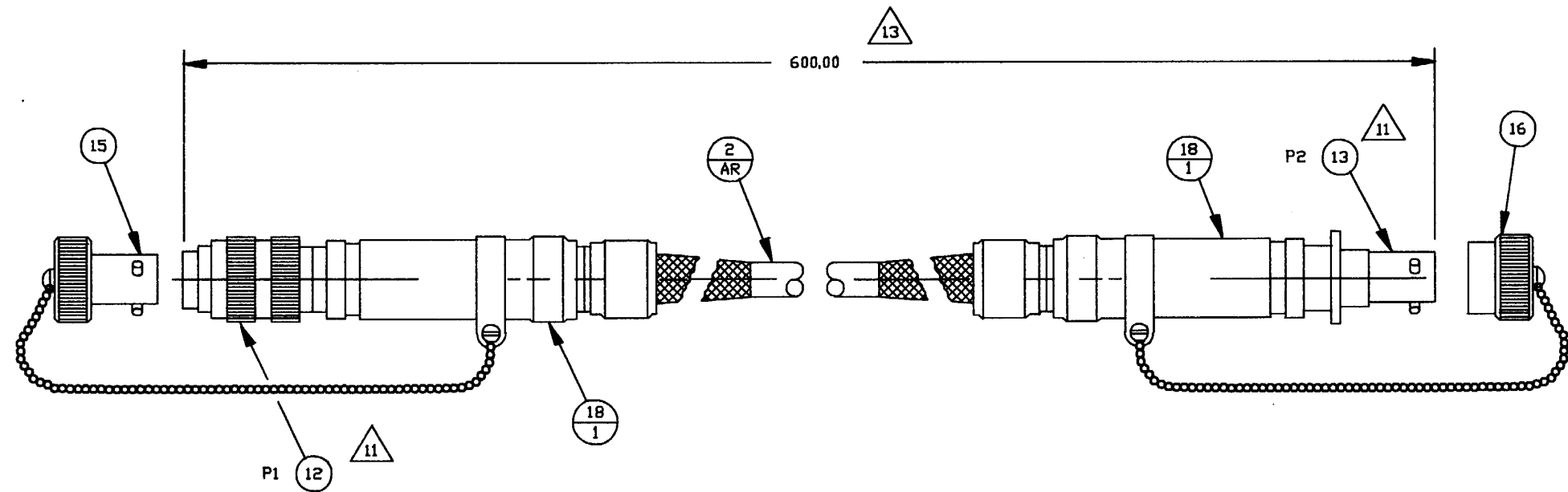

CABLE PREPARATION

BOTH ENDS

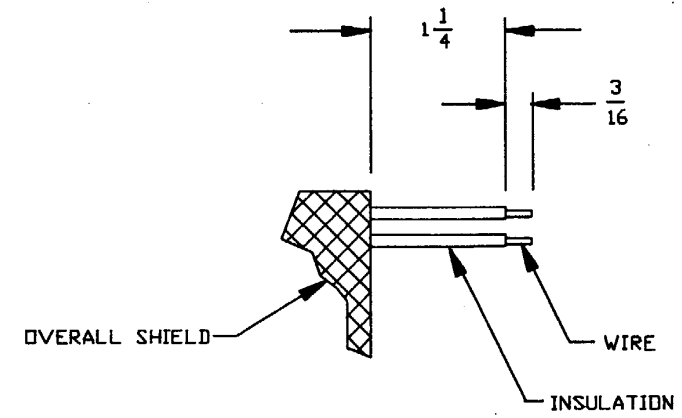

CABLE PREPARATION

BOTH ENDS

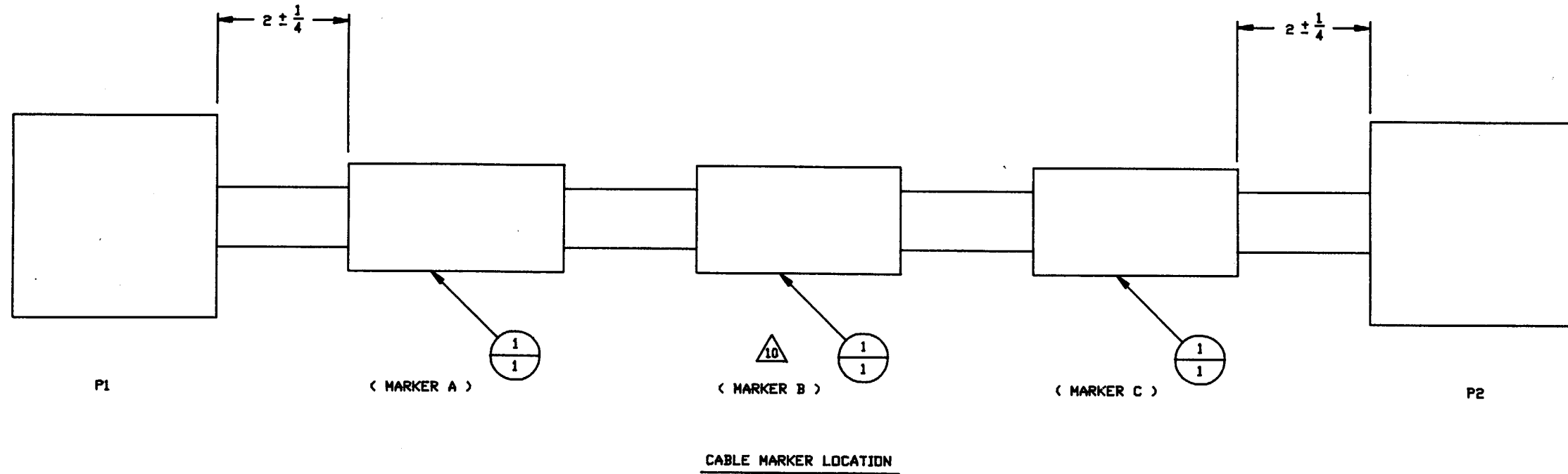

CHART A		
A MARKER	B MARKER	C MARKER
P1 26-PAIR	80063 A3093640	P2 EXTENSION



A3093640

NOTES :

1. IDENTIFY PART PER MIL-STD-130, TAG.
2. WORKMANSHIP SHALL BE IN ACCORDANCE WITH MIL-STD-454, REQUIREMENT 9.
3. DIMENSIONAL DATA IS BASED ON AMERICAN NATIONAL STANDARD ANSI Y14.5-1973.
4. P1 CRIMP INSERTION TOOL NO. M81969/17-03, REMOVAL TOOL NO. M81969/19-07, PER MIL-I-81969.P2 INSERTION TOOL NO. 200893-2 (AMP), REMOVE TOOL NO. 305183 (AMP).
5. P1 CRIMPING TOOL NO. M22520/1-10 WITH M22520/1-02 TURRET, PER MIL-C-22520.P2 CRIMPING TOOL NO. 90281-1 (AMP).
6. EACH CONDUCTOR SHALL BE TESTED FOR CONTINUITY AND CORRECT CONNECTIONS BETWEEN ITS TERMINATIONS, USING A POTENTIAL OF NOT MORE THAN 10 VOLTS. CONTINUITY CHECKS SHALL BE MADE FROM CONNECTOR CONTACT TO CONNECTOR CONTACT USING A CONTINUITY TESTER. CONTINUITY POINTS SHALL BE OBTAINED FROM THE CABLE WIRING DIAGRAM. WHERE SHIELD IS BONDED TO CONNECTOR ON BOTH ENDS, THE SHIELD CONTINUITY SHALL BE CHECKED FROM CONNECTOR SHELL TO CONNECTOR SHELL.
7. INSULATION RESISTANCE SHALL BE IN ACCORDANCE WITH METHOD 302 OF MIL-STD-202, TEST CONDITION B. THE POTENTIAL SHALL BE APPLIED BETWEEN EACH CONDUCTOR AND THE REMAINING CONDUCTORS CONNECTED TOGETHER AND TO THE SHIELD, AND CONNECTOR. THE INSULATION RESISTANCE OF THE CABLE ASSEMBLY SHALL NOT BE LESS THAN 100 MEGOHMS. EXCEPT THE INSULATION RESISTANCE OF A SHIELDED CONDUCTOR SHALL NOT BE LESS THAN 30 MEGOHMS.
8. DIELECTRIC WITHSTAND VOLTAGE. DIELECTRIC STRENGTH SHALL BE PERFORMED IN ACCORDANCE WITH METHOD 301 OF MIL-STD-202. A POTENTIAL OF 500 VOLTS DC SHALL BE APPLIED FOR 30 SECONDS MINIMUM. THE POTENTIAL SHALL BE APPLIED BETWEEN EACH CONDUCTOR AND THE REMAINING CONDUCTORS CONNECTED TOGETHER AND TO THE SHIELD AND CONNECTOR.
9. PARTIAL REFERENCE DESIGNATION ARE SHOWN. FOR COMPLETE REFERENCE DESIGNATION, PREFIX WITH UNIT NUMBER AND SUBASSEMBLY DESIGNATION.
10. SOLDERING SHALL BE IN ACCORDANCE WITH MIL-STD-454, REQUIREMENT 5.

△ ALL UNUSED POSITIONS IN CONNECTORS P1 & P2 ARE TO BE FILLED WITH CONTACTS.

12. DELETED
13. QUANTITY SHOWN IS IN INCHES.
- △ 14. TOLERANCE ON CABLE LENGTH SHALL BE +2, -1 INCHES.
- △ 15. DIMENSIONS SHOWN ON CABLE PREPARATION ILLUSTRATION ARE FOR REFERENCE ONLY.
16. VENDOR ITEM, SEE SPECIFICATION CONTROL DRAWING.

1	11	96906	MS3126F12-10P	CONNECTOR, ELECTRICAL, PLUG			
10	10	81349	M39029/31-240	CONTACT, CRIMP, PIN	MIL-C-39029/32		
	9						
	8						
	7						
REF	6	80063	A3092728	TEST PROCEDURE/DATA SHEET POWER AND SIGNAL CABLE TEST			
1	5	80063	A3092984-3	BACKSHELL, EMI/RFI			16
478	4	80063	A3093562-9	CABLE, ELECTRICAL, SPECIAL PURPOSE			13 , 16
1	3	80063	A3092921-1	CONNECTOR, AMP			16
16	2	80063	A3092920	CONTACT, TYPE II MULTIMATE			16
1	1	80063	A3092918-1	BACKSHELL, AMP			16
QTY REQD	FIND NO.	FSCM NO.	PART NUMBER OR IDENTIFYING NO.	NOMENCLATURE OR DESCRIPTION	SPEC/STD	SHEET NO.	NOTE
PARTS LIST							

A3093641

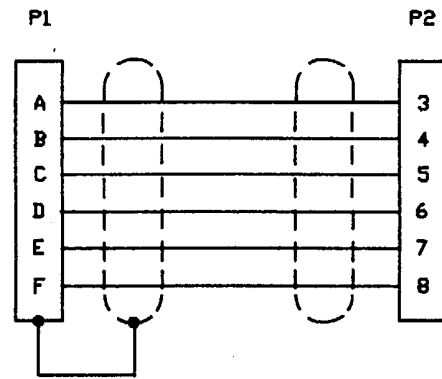

WIRING DIAGRAM

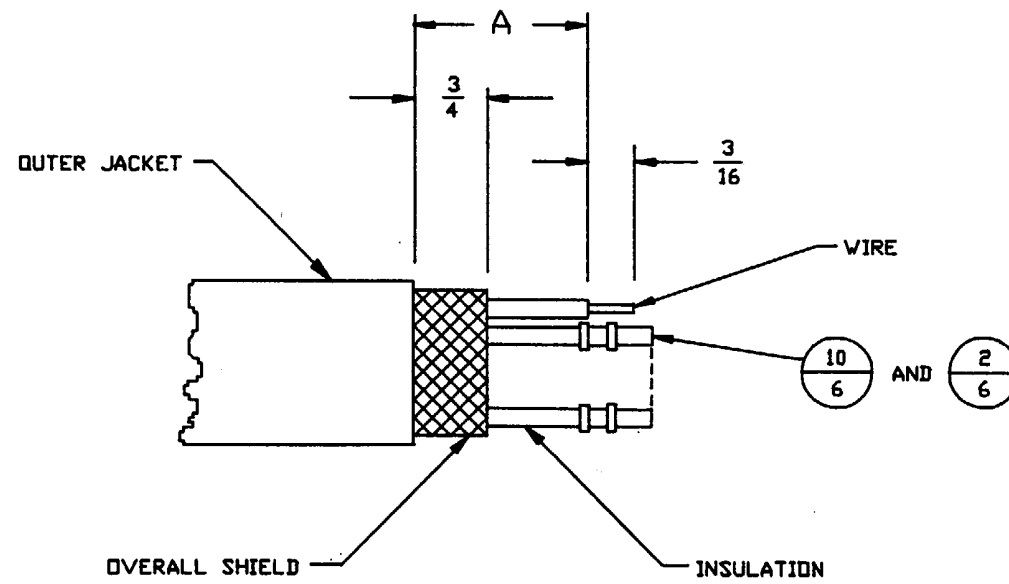
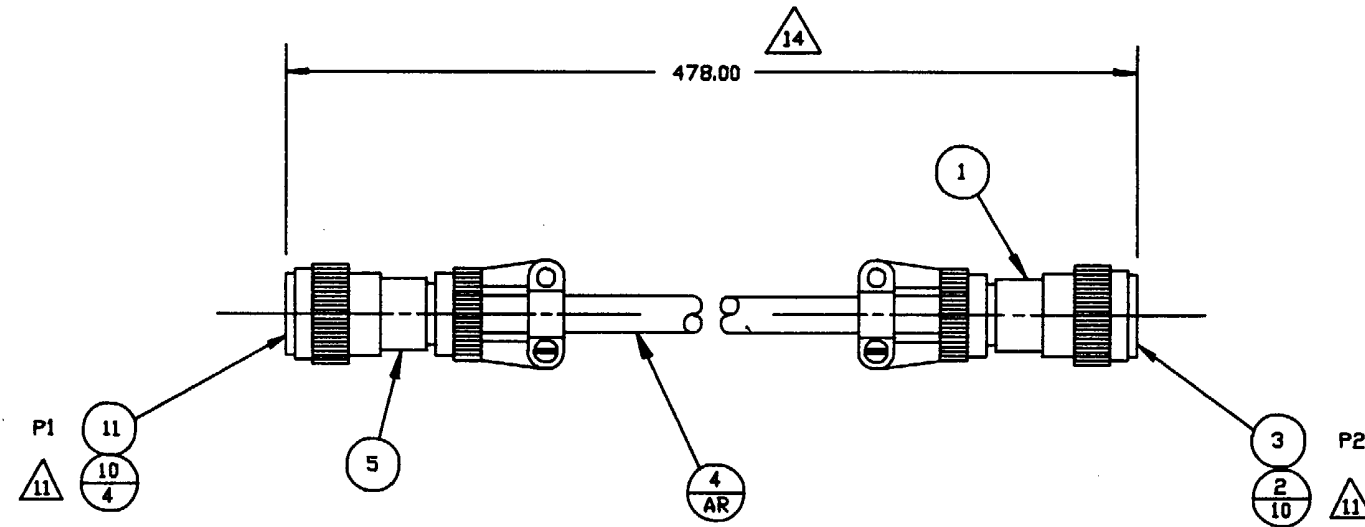

CABLE PREPARATION



SCALE : 2/1
BOTH ENDS





CHART	
END TYPE	DIMENSION A
P1	1.25 REF
P2	1.00 REF

A3093641

NOTES :

1. IDENTIFY PART PER MIL-STD-130, TAG.
2. WORKMANSHIP SHALL BE IN ACCORDANCE WITH MIL-STD-454, REQUIREMENT 9.
3. DIMENSIONAL DATA IS BASED ON AMERICAN NATIONAL STANDARD ANSI Y14.5-1973.
4. CRIMP INSERTION TOOL NO. M81969/17-03, REMOVAL TOOL NO. M81969/19-07, PER MIL-I-81969.
5. CRIMPING TOOL NO. M22520/1-01 WITH M22520/1-02 TURRET, PER MIL-C-22520.
6. EACH CONDUCTOR SHALL BE TESTED FOR CONTINUITY AND CORRECT CONNECTIONS BETWEEN ITS TERMINATIONS, USING A POTENTIAL OF NOT MORE THAN 10 VOLTS. CONTINUITY CHECKS SHALL BE MADE FROM CONNECTOR CONTACT TO CONNECTOR CONTACT USING A CONTINUITY TESTER. CONTINUITY POINTS SHALL BE OBTAINED FROM THE CABLE WIRING DIAGRAM. WHERE SHIELD IS BONDED TO CONNECTOR ON BOTH ENDS, THE SHIELD CONTINUITY SHALL BE CHECKED FROM CONNECTOR SHELL TO CONNECTOR SHELL.
7. INSULATION RESISTANCE SHALL BE IN ACCORDANCE WITH METHOD 302 OF MIL-STD-202, TEST CONDITION B. THE POTENTIAL SHALL BE APPLIED BETWEEN EACH CONDUCTOR AND THE REMAINING CONDUCTORS CONNECTED TOGETHER AND TO THE SHIELD, AND CONNECTOR. THE INSULATION RESISTANCE OF THE CABLE ASSEMBLY SHALL NOT BE LESS THAN 100 MEGOHMS. EXCEPT THE INSULATION RESISTANCE OF A SHIELDED CONDUCTOR SHALL NOT BE LESS THAN 30 MEGOHMS.
8. DIELECTRIC WITHSTAND VOLTAGE. DIELECTRIC STRENGTH SHALL BE PERFORMED IN ACCORDANCE WITH METHOD 301 OF MIL-STD-202. A POTENTIAL OF 500 VOLTS DC SHALL BE APPLIED FOR 30 SECONDS MINIMUM. THE POTENTIAL SHALL BE APPLIED BETWEEN EACH CONDUCTOR AND THE REMAINING CONDUCTORS CONNECTED TOGETHER AND TO THE SHIELD AND CONNECTOR.
9. PARTIAL REFERENCE DESIGNATION ARE SHOWN. FOR COMPLETE REFERENCE DESIGNATION, PREFIX WITH UNIT NUMBER AND SUBASSEMBLY DESIGNATION.

 LOCATE MARKER B CENTRALLY, ± 6 INCHES.

-  ALL UNUSED POSITIONS IN CONNECTORS P1 & P2 ARE TO BE FILLED WITH CONTACTS.
12. QUANTITY SHOWN IS IN INCHES.
-  TOLERANCE ON CABLE LENGTH SHALL BE +6, -2 INCHES.
-  DIMENSIONS SHOWN ON CABLE PREPARATION ILLUSTRATION ARE FOR REFERENCE ONLY.
15. VENDOR ITEM, SEE SPECIFICATION CONTROL DRAWING.
-  MARK PER A3092959.

2	18	80063	SM-A-838108-8	ADAPTER			15
	17						
	16						
2	15	96906	MS27501B23CN	DUST, CAP			
	14						
	13						
2	12	96906	MS27467T2353S	CONNECTOR, ELECTRICAL, PLUG			
	11						
	10						
106	9	81349	M39029/56-351	CONTACT, CRIMP, SOCKET	MIL-C-39029/56		
	8						
	7						
	6						
REF	5	80063	A3092728	TEST PROCEDURE/DATA SHEET POWER AND SIGNAL CABLE TEST			
	4						
	3						
600	2	81349	WM-130 A/G	CABLE ASSY, TELEPHONE	MIL-C-55036		12
3	1	80063	A3092925-5	CABLE, MARKER			15
QTY REQD	FIND NO.	FSCM NO.	PART NUMBER OR IDENTIFYING NO.	NOMENCLATURE OR DESCRIPTION	SPEC/STD	SHEET NO.	NOTE
PARTS LIST							

A3093642

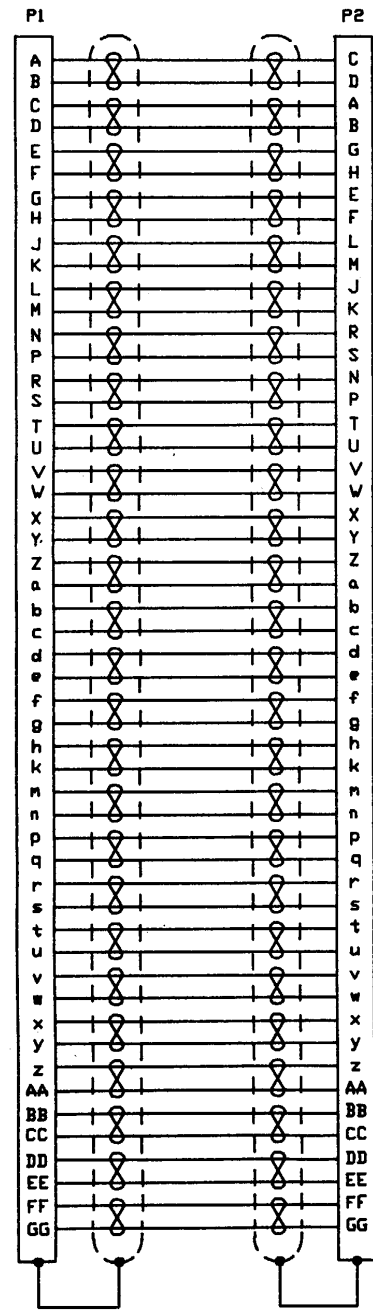

WIRING DIAGRAM

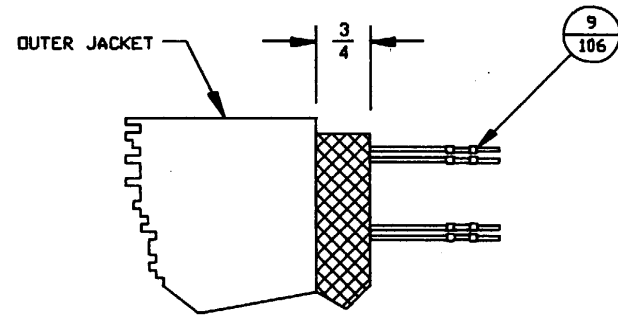
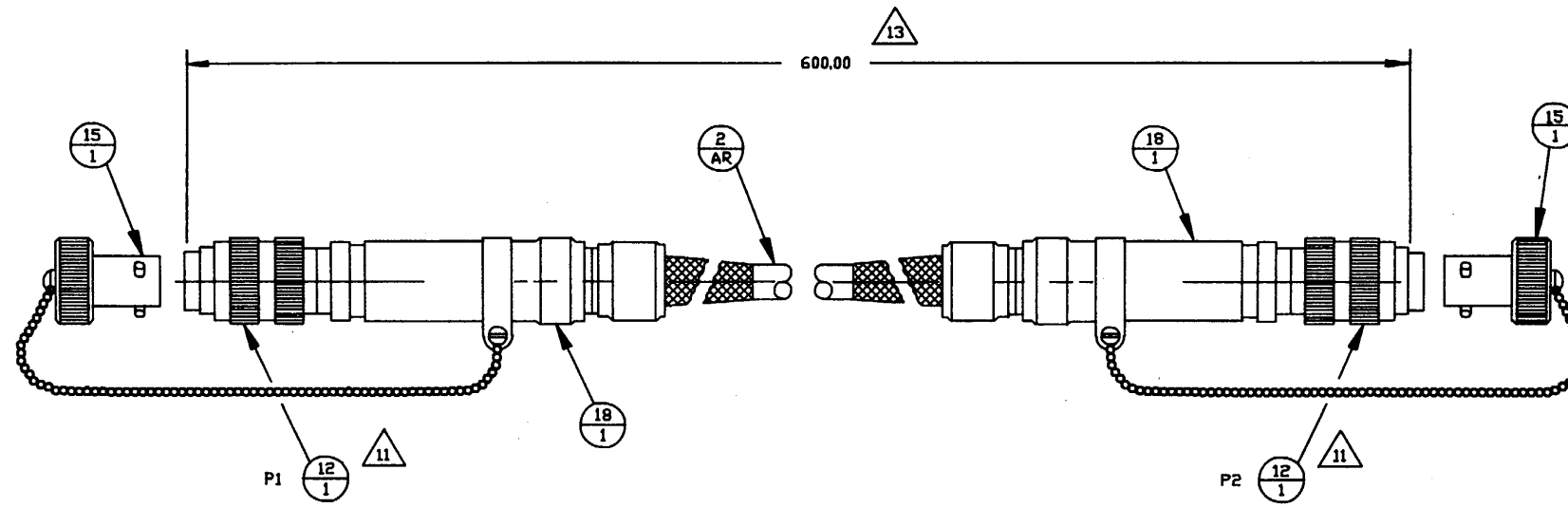

14 CABLE PREPARATION
BOTH ENDS

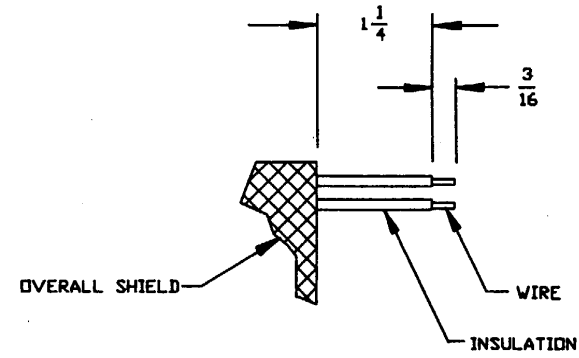

14 CABLE PREPARATION
BOTH ENDS

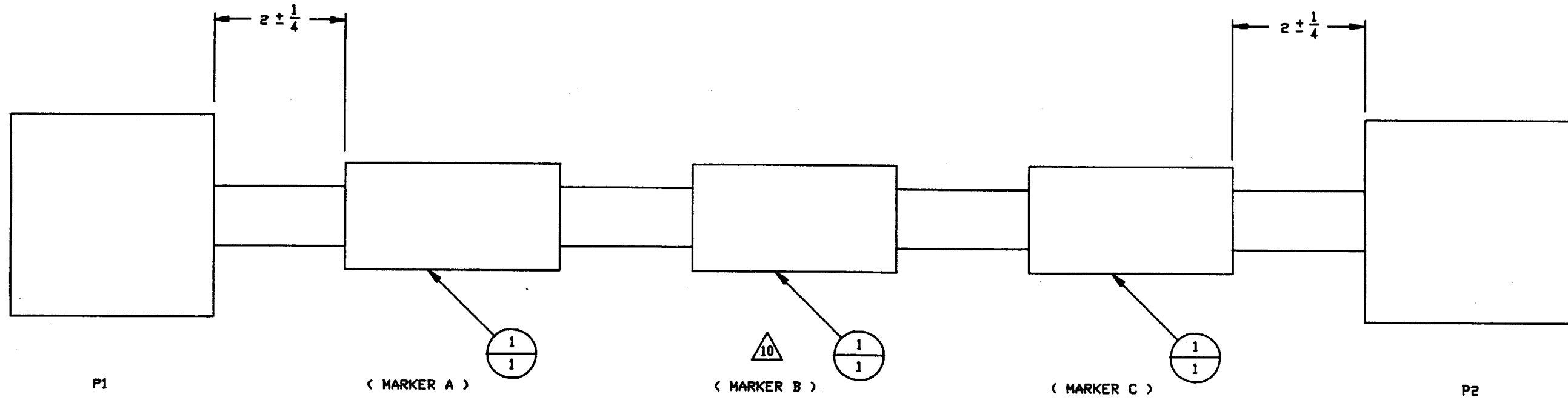

CHART A		
A MARKER	B MARKER	C MARKER
P1 26-PAIR	80063 A3093642	P2 26-PAIR

16

A3093642

NOTES :

1. IDENTIFY PART PER MIL-STD-130, TAG.
2. WORKMANSHIP SHALL BE IN ACCORDANCE WITH MIL-STD-454, REQUIREMENT 9.
3. DIMENSIONAL DATA IS BASED ON AMERICAN NATIONAL STANDARD ANSI Y14.5-1973.
4. P1 CRIMP INSERTION TOOL NO. M81969/17-03, REMOVAL TOOL NO. M81969/19-07, PER MIL-I-81969.P2 INSERTION TOOL. M81969/2-03, REMOVAL TOOL NO. M81969/3-03, PER MIL-I-81969.
5. P1 CRIMPING TOOL NO. M22520/1-10 WITH M22520/1-02 TURRET AND P2 WITH M22520/1-04 BL TURRET, PER MIL-C-22520.
6. EACH CONDUCTOR SHALL BE TESTED FOR CONTINUITY AND CORRECT CONNECTIONS BETWEEN ITS TERMINATIONS, USING A POTENTIAL OF NOT MORE THAN 10 VOLTS. CONTINUITY CHECKS SHALL BE MADE FROM CONNECTOR CONTACT TO CONNECTOR CONTACT USING A CONTINUITY TESTER. CONTINUITY POINTS SHALL BE OBTAINED FROM THE CABLE WIRING DIAGRAM. WHERE SHIELD IS BONDED TO CONNECTOR ON BOTH ENDS, THE SHIELD CONTINUITY SHALL BE CHECKED FROM CONNECTOR SHELL TO CONNECTOR SHELL.
7. INSULATION RESISTANCE SHALL BE IN ACCORDANCE WITH METHOD 302 OF MIL-STD-202, TEST CONDITION B. THE POTENTIAL SHALL BE APPLIED BETWEEN EACH CONDUCTOR AND THE REMAINING CONDUCTORS CONNECTED TOGETHER AND TO THE SHIELD, AND CONNECTOR. THE INSULATION RESISTANCE OF THE CABLE ASSEMBLY SHALL NOT BE LESS THAN 100 MEGOHMS. EXCEPT THE INSULATION RESISTANCE OF A SHIELDED CONDUCTOR SHALL NOT BE LESS THAN 30 MEGOHMS.
8. DIELECTRIC WITHSTAND VOLTAGE. DIELECTRIC STRENGTH SHALL BE PERFORMED IN ACCORDANCE WITH METHOD 301 OF MIL-STD-202. A POTENTIAL OF 500 VOLTS DC SHALL BE APPLIED FOR 30 SECONDS MINIMUM. THE POTENTIAL SHALL BE APPLIED BETWEEN EACH CONDUCTOR AND THE REMAINING CONDUCTORS CONNECTED TOGETHER AND TO THE SHIELD AND CONNECTOR.
9. PARTIAL REFERENCE DESIGNATION ARE SHOWN. FOR COMPLETE REFERENCE DESIGNATION, PREFIX WITH UNIT NUMBER AND SUBASSEMBLY DESIGNATION.
10. SOLDERING SHALL BE IN ACCORDANCE WITH MIL-STD-454, REQUIREMENT 5.

△ ALL UNUSED POSITIONS IN CONNECTORS P1 & P2 ARE TO BE FILLED WITH CONTACTS.

12. COMPLETE PART NUMBER FOR THIS ASSEMBLY SHALL INCLUDE APPLICABLE DASH NUMBER INDICATED IN QUANTITY REQUIRED COLUMN.
13. QUANTITY SHOWN IS IN INCHES.
- △14 TOLERANCE ON CABLE LENGTH SHALL BE +2, -1 INCHES.
- △15 DIMENSIONS SHOWN ON CABLE PREPARATION ILLUSTRATION ARE FOR REFERENCE ONLY.
16. VENDOR ITEM, SEE SPECIFICATION CONTROL DRAWING.
- △17 DISCARD INNER RING ON BACKSHELL THAT SLIDES ONTO CONNECTOR INSERT.

1	1	1	9	96906	MS3126F12-3S	CONNECTOR, ELECTRICAL, PLUG			
1	1	1	8	96906	MS27467T13B4P	CONNECTOR, ELECTRICAL, PLUG			
			7						
REF	REF	REF	6	80063	A3092728	TEST PROCEDURE/DATA SHEETS POWER AND SIGNAL CABLE TEST			
4	4	4	5	81349	M39029/58-364	CONTACT, CRIMP, PINS	MIL-C-39029/47		
10	10	10	4	81349	M39029/32-247	CONTACT, CRIMP, SOCKETS	MIL-C-39029/32		
93	81	45	3	81349	M27500A18VA3S0	CABLE, ELECTRICAL	MIL-C-27500		13
			2						
2	2	2	1	80063	A3093589-42	BACKSHELL, EMI/RFI			16
QTY REQD	QTY REQD	QTY REQD	FIND NO.	FSCM NO.	PART NUMBER OR IDENTIFYING NO.	NOMENCLATURE OR DESCRIPTION	SPEC/STD	SHEET NO.	NOTE
-3	-2	-1			PARTS LIST				

A3093643

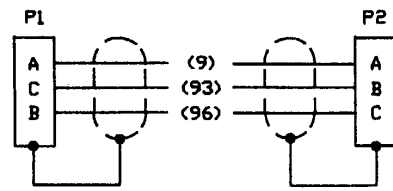
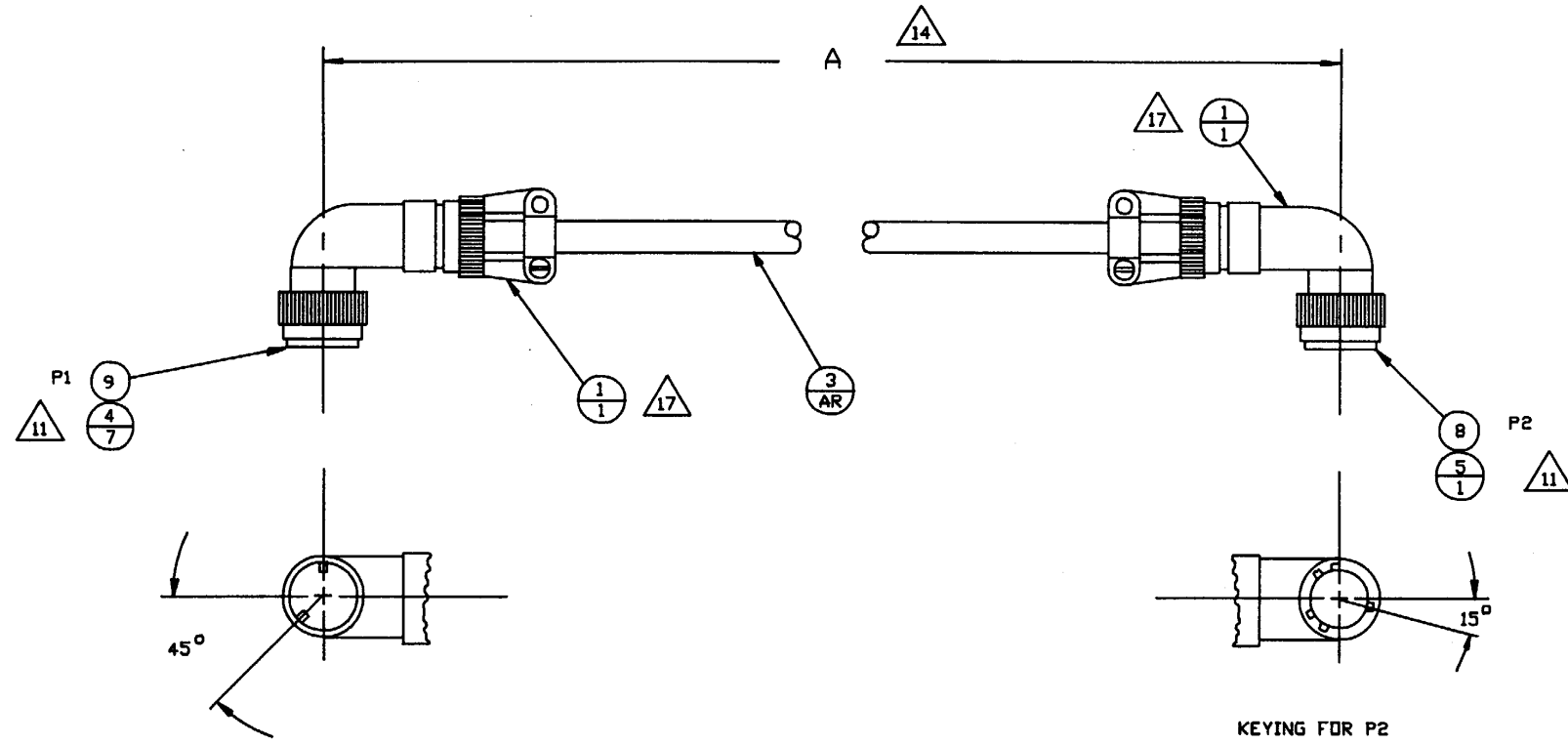

WIRING DIAGRAM

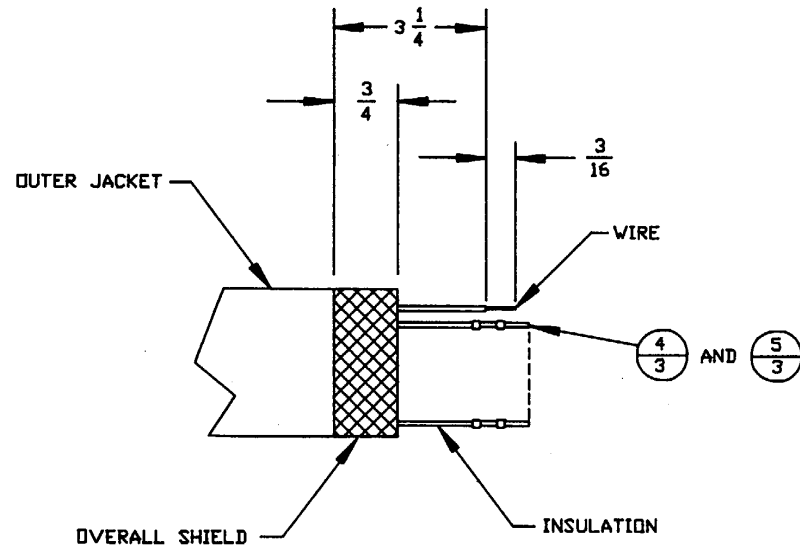

CABLE PREPARATION 15





SCALE : 2/1
BOTH ENDS

CHART	
DASH NO.	DIMENSION A
1	45.00
2	81.00
3	93.00

NOTES :

1. IDENTIFY PART PER MIL-STD-130, TAG.
2. WORKMANSHIP SHALL BE IN ACCORDANCE WITH MIL-STD-454, REQUIREMENT 9.
3. DIMENSIONAL DATA IS BASED ON AMERICAN NATIONAL STANDARD ANSI Y14.5-1973.
4. CRIMP INSERTION TOOL NO. M81969/17-04, REMOVAL TOOL NO. M81969/19-08, PER MIL-I-81969.
5. CRIMPING TOOL NO. M22520/1-01 WITH M22520/1-02 BL TURRET, PER MIL-C-22520.
6. EACH CONDUCTOR SHALL BE TESTED FOR CONTINUITY AND CORRECT CONNECTIONS BETWEEN ITS TERMINATIONS, USING A POTENTIAL OF NOT MORE THAN 10 VOLTS. CONTINUITY CHECKS SHALL BE MADE FROM CONNECTOR CONTACT TO CONNECTOR CONTACT USING A CONTINUITY TESTER. CONTINUITY POINTS SHALL BE OBTAINED FROM THE CABLE WIRING DIAGRAM. WHERE SHIELD IS BONDED TO CONNECTOR ON BOTH ENDS, THE SHIELD CONTINUITY SHALL BE CHECKED FROM CONNECTOR SHELL TO CONNECTOR SHELL.
7. INSULATION RESISTANCE SHALL BE IN ACCORDANCE WITH METHOD 302 OF MIL-STD-202, TEST CONDITION B. THE POTENTIAL SHALL BE APPLIED BETWEEN EACH CONDUCTOR AND THE REMAINING CONDUCTORS CONNECTED TOGETHER AND TO THE SHIELD, AND CONNECTOR. THE INSULATION RESISTANCE OF THE CABLE ASSEMBLY SHALL NOT BE LESS THAN 100 MEGOHMS, EXCEPT THE INSULATION RESISTANCE OF A SHIELDED CONDUCTOR SHALL NOT BE LESS THAN 30 MEGOHMS.
8. DIELECTRIC WITHSTANDING VOLTAGE. DIELECTRIC STRENGTH SHALL BE PERFORMED IN ACCORDANCE WITH METHOD 301 OF MIL-STD-202. A POTENTIAL OF 500 VOLTS DC SHALL BE APPLIED FOR 30 SECONDS MINIMUM. THE POTENTIAL SHALL BE APPLIED BETWEEN EACH CONDUCTOR AND THE REMAINING CONDUCTORS CONNECTED TOGETHER AND TO THE SHIELD AND CONNECTOR.
9. PARTIAL REFERENCE DESIGNATION ARE SHOWN. FOR COMPLETE REFERENCE DESIGNATION, PREFIX WITH UNIT NUMBER AND SUBASSEMBLY DESIGNATION.
10. SOLDERING SHALL BE IN ACCORDANCE WITH MIL-STD-454, REQUIREMENT 5.

 DIMENSION B (RANGE 1/4 TO 1/2) AND DIMENSION C (RANGE 1/2 TO 3/4) CAN INCREASE OR DECREASE PROPORTIONALLY AS LONG AS 1-1/4 OVERALL DIMENSION IS HELD.

12. COMPLETE PART NUMBER FOR THIS ASSEMBLY SHALL INCLUDE APPLICABLE DASH NUMBER INDICATED IN QUANTITY REQUIRED COLUMN.
-  ALL SHIELDS MUST TERMINATE INSIDE OF EMI BACKSHELL.
-  TRIM FIND NO. 11 TO LENGTH IN CHART A.
-  TOLERANCE ON CABLE LENGTH SHALL BE +2, -1 INCHES.
-  DIMENSIONS SHOWN IN CABLE PREPARATION ILLUSTRATION ARE FOR REFERENCE ONLY.
17. VENDOR ITEM-SEE SPECIFICATION CONTROL DRAWING.

1	1	12	96906	MS3126F12-3S	CONNECTOR, ELECTRICAL			
1	1	11	80063	A3092927-1	CABLE ASSY, MOLDED CONNECTOR			14, 17
3	3	10	81349	M39029/32-247	CONTACT, CRIMP, SOCKET	MIL-C-39029/32		
		9						
		8						
		7						
		6						
REF	REF	5	80063	A3092728	TEST PROCEDURE/DATA SHEET POWER AND SIGNAL CABLE TEST			
		4						
		3						
1	1	2	80063	A3093577-7	BACKSHELL, EMI/RFI			17
1	1	1	80063	A3093003	ADAPTER			17
QTY REQD	QTY REQD	FIND NO.	FSCM NO.	PART NUMBER OR IDENTIFYING NO.	NOMENCLATURE OR DESCRIPTION	SPEC/STD	SHEET NO.	NOTE
-2	-1				PARTS LIST			

A3093644

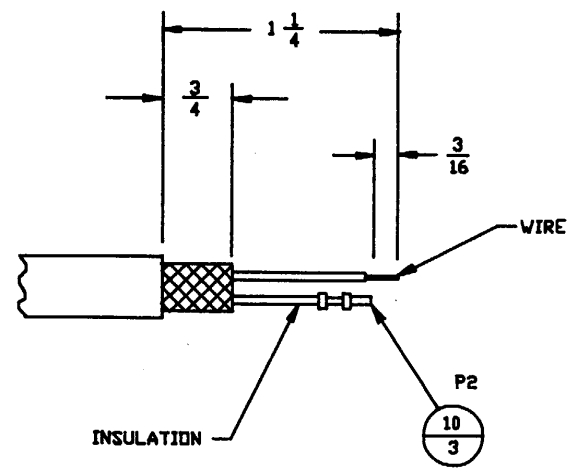
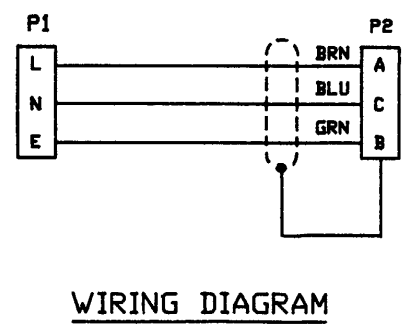
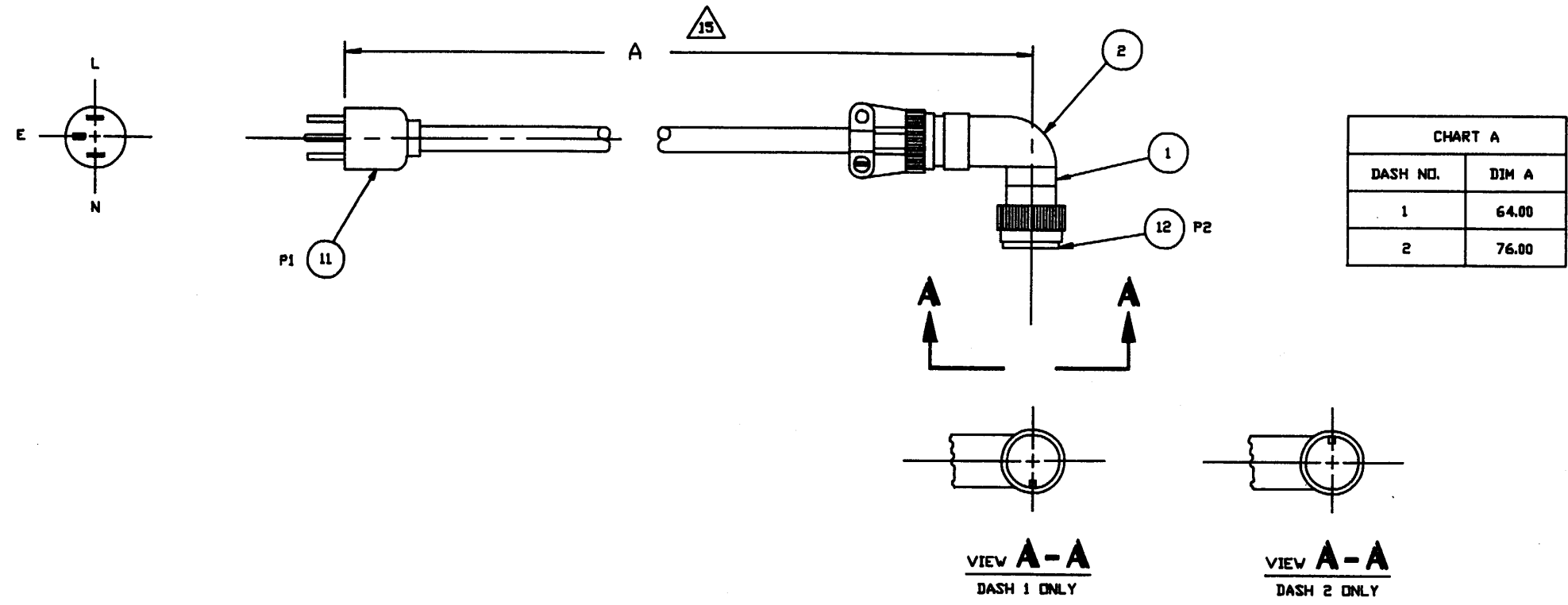

SCALE : 2/1
SINGLE END

A3093644

NOTES :

1. IDENTIFY PART PER MIL-STD-130, TAG.
2. WORKMANSHIP SHALL BE IN ACCORDANCE WITH MIL-STD-454, REQUIREMENT 9.
3. DIMENSIONAL DATA IS BASED ON AMERICAN NATIONAL STANDARD ANSI Y14.5-1973.
4. CRIMP INSERTION TOOL NO. M81969/8-07, REMOVAL TOOL NO M81969/8-08, P2 ONLY, PER MIL-I-81969.
5. CRIMPING TOOL NO. M22520/1-01 WITH M22520/1-04 BL TURRET, P2 ONLY, PER MIL-C-22520.
6. EACH CONDUCTOR SHALL BE TESTED FOR CONTINUITY AND CORRECT CONNECTIONS BETWEEN ITS TERMINATIONS, USING A POTENTIAL OF NOT MORE THAN 10 VOLTS. CONTINUITY CHECKS SHALL BE MADE FROM CONNECTOR CONTACT TO CONNECTOR CONTACT USING A CONTINUITY TESTER. CONTINUITY POINTS SHALL BE OBTAINED FROM THE CABLE WIRING DIAGRAM. WHERE SHIELD IS BONDED TO CONNECTOR ON BOTH ENDS, THE SHIELD CONTINUITY SHALL BE CHECKED FROM CONNECTOR SHELL TO CONNECTOR SHELL.
7. INSULATION RESISTANCE SHALL BE IN ACCORDANCE WITH METHOD 302 OF MIL-STD-202, TEST CONDITION B. THE POTENTIAL SHALL BE APPLIED BETWEEN EACH CONDUCTOR AND THE REMAINING CONDUCTORS CONNECTED TOGETHER AND TO THE SHIELD, AND CONNECTOR. THE INSULATION RESISTANCE OF THE CABLE ASSEMBLY SHALL NOT BE LESS THAN 100 MEGOHMS. EXCEPT THE INSULATION RESISTANCE OF A SHIELDED CONDUCTOR SHALL NOT BE LESS THAN 30 MEGOHMS.
8. DIELECTRIC WITHSTANDING VOLTAGE. DIELECTRIC STRENGTH SHALL BE PERFORMED IN ACCORDANCE WITH METHOD 301 OF MIL-STD-202. A POTENTIAL OF 500 VOLTS DC SHALL BE APPLIED FOR 30 SECONDS MINIMUM. THE POTENTIAL SHALL BE APPLIED BETWEEN EACH CONDUCTOR AND THE REMAINING CONDUCTORS CONNECTED TOGETHER AND TO THE SHIELD AND CONNECTOR.
9. PARTIAL REFERENCE DESIGNATION ARE SHOWN. FOR COMPLETE REFERENCE DESIGNATION, PREFIX WITH UNIT NUMBER AND SUBASSEMBLY DESIGNATION.
10. SOLDERING SHALL BE IN ACCORDANCE WITH MIL-STD-454, REQUIREMENTS 5.

⚠ ALL UNUSED POSITIONS IN CONNECTOR P2 ARE TO BE FILLED WITH CONTACTS.

12. COMPLETE PART NUMBER FOR THIS ASSEMBLY SHALL INCLUDE APPLICABLE DASH NUMBER INDICATED IN QUANTITY REQUIRED COLUMN.
13. QUANTITY SHOWN IS IN INCHES.
- ⚠ 14 TOLERANCE ON CABLE LENGTH SHALL BE +2, -1 INCHES.
- ⚠ 15 WIRE ENDS ARE TO BE TINNED PER MIL-STD-454, REQUIREMENT 5.
- ⚠ 16 DIMENSIONS SHOWN IN CABLE PREPARATION ILLUSTRATION ARE FOR REFERENCE ONLY.
17. VENDOR ITEM-SEE SPECIFICATION CONTROL DRAWING.
- ⚠ 18 HEAT SHRINK APPROPRIATE LENGTH OF FIND NO. 12 OVER OVERALL JACKET ON P1 END FOR FILLER.

AR	AR	12	81349	M23053/5-107-0	INSULATION SLEEVING	MIL-I-23053/5		
1	1	11	81349	MW10F(M)A11	CONNECTOR, ELECTRICAL, PLUG	MIL-C-55181		
1	1	10	96906	MS27467T13B4P	CONNECTOR, ELECTRICAL, PLUG			
		9						
4	4	8	81349	M39029/58-364	CONTACT, CRIMP, PINS	MIL-C-39029/58		
116	102	7	81349	M27500A18VA3S0	CABLE, ELECTRICAL	MIL-C-27500		13
		6						
REF	REF	5	80063	A3092728	TEST PROCEDURE/DATA SHEET POWER AND SIGNAL CABLE TEST			
		4						
		3						
1	1	2	80063	A3093589-2	BACKSHELL, EMI/RFI			17
		1						
QTY REQD	QTY REQD	FIND NO.	FSCM NO.	PART NUMBER OR IDENTIFYING NO.	NOMENCLATURE OR DESCRIPTION	SPEC/STD	SHEET NO.	NOTE
-2	-1	PARTS LIST						

A3093645

CHART A	
DASH NO.	DIMENSION A
-1	102.00
-2	116.00

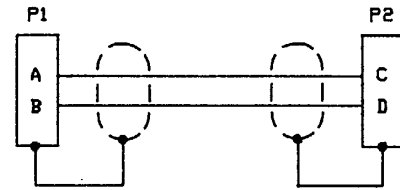
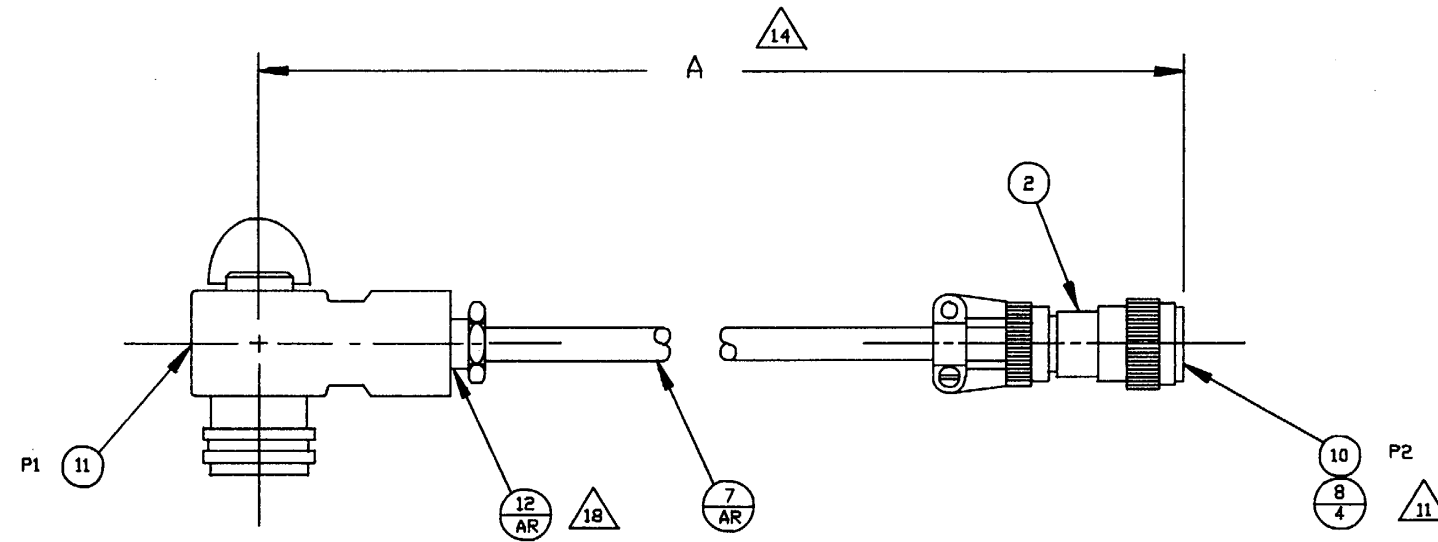

WIRING DIAGRAM

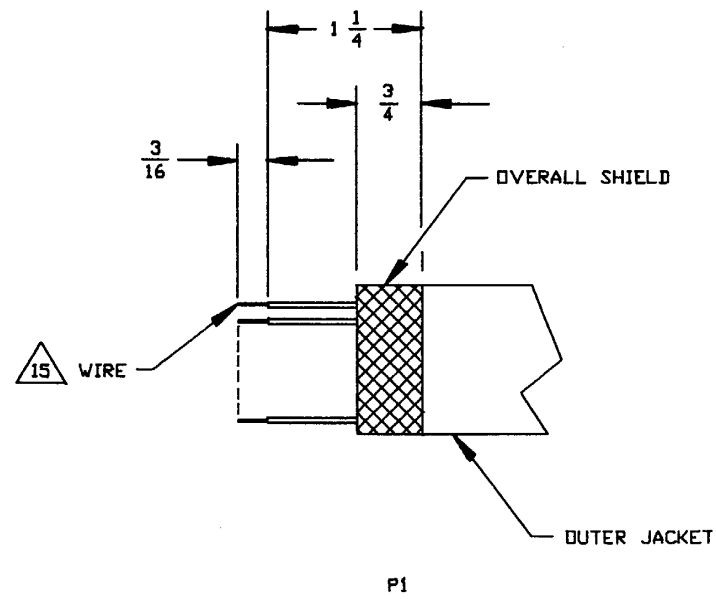
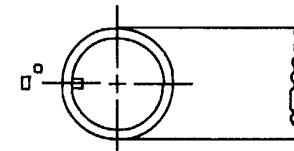

CABLE PREPARATION $\triangle 16$

SCALE : 2/1

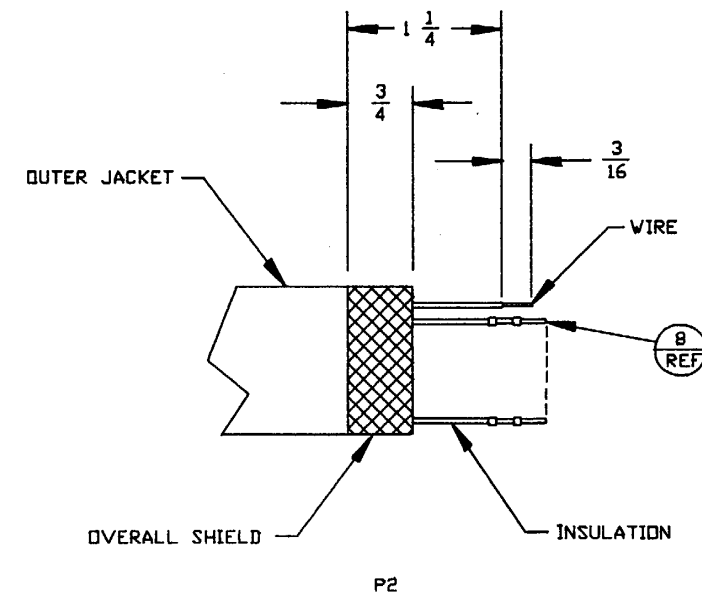

CABLE PREPARATION $\triangle 16$







SCALE : 2/1

A3093645

NOTES :

1. IDENTIFY PART PER MIL-STD-130, TAG.
2. WORKMANSHIP SHALL BE IN ACCORDANCE WITH MIL-STD-454, REQUIREMENT 9.
3. DIMENSIONAL DATA IS BASED ON AMERICAN NATIONAL STANDARD ANSI Y14.5-1973.
4. CRIMP INSERTION TOOL NO. M81969/17-03, REMOVAL TOOL NO. M81969/19-07, PER MIL-I-81969.
5. CRIMPING TOOL NO. M22520/1-01 WITH M22520/1-02 TURRET, PER MIL-C-22520.
6. EACH CONDUCTOR SHALL BE TESTED FOR CONTINUITY AND CORRECT CONNECTIONS BETWEEN ITS TERMINATIONS, USING A POTENTIAL OF NOT MORE THAN 10 VOLTS. CONTINUITY CHECKS SHALL BE MADE FROM CONNECTOR CONTACT TO CONNECTOR CONTACT USING A CONTINUITY TESTER. CONTINUITY POINTS SHALL BE OBTAINED FROM THE CABLE WIRING DIAGRAM. WHERE SHIELD IS BONDED TO CONNECTOR ON BOTH ENDS, THE SHIELD CONTINUITY SHALL BE CHECKED FROM CONNECTOR SHELL TO CONNECTOR SHELL.
7. INSULATION RESISTANCE SHALL BE IN ACCORDANCE WITH METHOD 302 OF MIL-STD-202, TEST CONDITION B. THE POTENTIAL SHALL BE APPLIED BETWEEN EACH CONDUCTOR AND THE REMAINING CONDUCTORS CONNECTED TOGETHER AND TO THE SHIELD, AND CONNECTOR. THE INSULATION RESISTANCE OF THE CABLE ASSEMBLY SHALL NOT BE LESS THAN 100 MEGOHMS. EXCEPT THE INSULATION RESISTANCE OF A SHIELDED CONDUCTOR SHALL NOT BE LESS THAN 30 MEGOHMS.
8. DIELECTRIC WITHSTANDING VOLTAGE. DIELECTRIC STRENGTH SHALL BE PERFORMED IN ACCORDANCE WITH METHOD 301 OF MIL-STD-202. A POTENTIAL OF 500 VOLTS DC SHALL BE APPLIED FOR 30 SECONDS MINIMUM. THE POTENTIAL SHALL BE APPLIED BETWEEN EACH CONDUCTOR AND THE REMAINING CONDUCTORS CONNECTED TOGETHER AND TO THE SHIELD AND CONNECTOR.
9. PARTIAL REFERENCE DESIGNATION ARE SHOWN. FOR COMPLETE REFERENCE DESIGNATION, PREFIX WITH UNIT NUMBER AND SUBASSEMBLY DESIGNATION.
10. SOLDERING SHALL BE IN ACCORDANCE WITH MIL-STD-454, REQUIREMENT 5.

 DIMENSION B (RANGE 1/4 TO 1/2) AND DIMENSION C (RANGE 1/2 TO 3/4) CAN INCREASE OR DECREASE PROPORTIONALLY TO ALLOW SOLDER FERRULE FERRULE PLACEMENT TO BE VARIED.

-  12. INSTALL FERRULES ON SHIELDED TWISTED PAIRS AND SINGLE SHIELDED WIRE STARTING, 1/2 INCH FROM END OF CONNECTOR, SO FERRULES WILL NOT TERMINATE AT SAME LOCATION.
-  13. WHEN BACKSHELL'S DIA. IS TOO SMALL TO CONTAIN INDIVIDUAL FERRULES IT IS PERMISSIBLE TO TERMINATE 2 SHIELDED WIRES IN THE SAME FERRULE.
-  14. ALL SHIELDS MUST TERMINATE INSIDE OF EMI BACKSHELL.
-  15. ALL UNUSED POSITIONS IN CONNECTORS P1 & P2 ARE TO BE FILLED WITH CONTACTS.
16. QUANTITY SHOWN IS IN INCHES.
-  17. TOLERANCE ON CABLE LENGTH SHALL BE +2, -1 INCHES.
-  18. DIMENSIONS SHOWN ON CABLE PREPARATION ILLUSTRATION ARE FOR REFERENCE ONLY.
-  19. PLACE HEAT SHRINK SLEEVING, ITEM 8, UNDER SOLDER FERRULE TO PROTECT WIRE.
20. VENDOR ITEM, SEE SPECIFICATION CONTROL DRAWING.

2	12	96906	MS3126F12-10S	CONNECTOR, ELECTRICAL, PLUG			
3	11	80063	A3093335-1	FERRULE, SOLDER			20
20	10	81349	M39029/32-259	CONTACT, CRIMP, SOCKET	MIL-C-39029/32		
	9						
4	8	81349	A3092728	HEAT SHRINK SLEEVING	MIL-I-23053/5		16
	7						
	6						
REF	5	80063	A3092984-3	TEST PROCEDURE/DATA SHEET POWER AND SIGNAL CABLE TEST			
	4						
1	3	80063	A3092728	BACKSHELL, EMI/RFI			20
1	2	80063	A3093589-2	BACKSHELL, EMI/RFI			20
170	1	80063	A3093563-2	CABLE, ELECTRICAL, SPECIAL PURPOSE			16 , 20
QTY REQD	FIND NO.	FSCM NO.	PART NUMBER OR IDENTIFYING NO.	NOMENCLATURE OR DESCRIPTION	SPEC/STD	SHEET NO.	NOTE
PARTS LIST							

A3093646

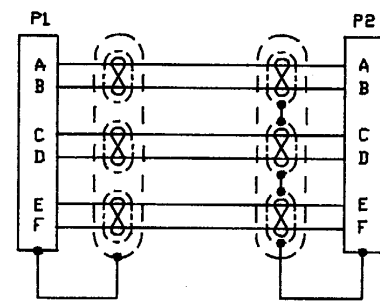

WIRING DIAGRAM

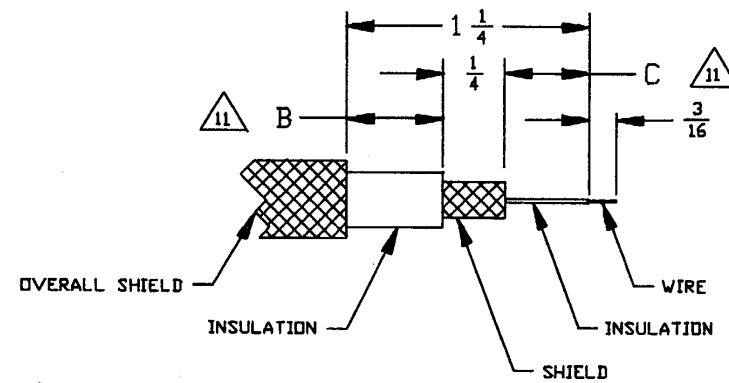
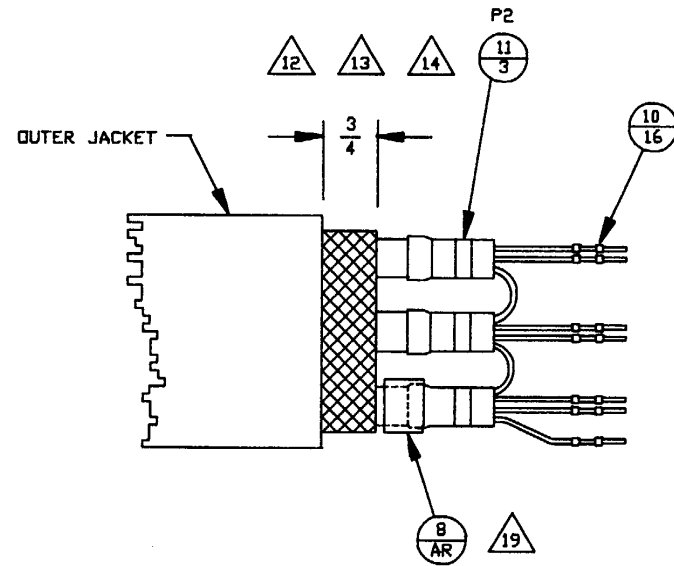
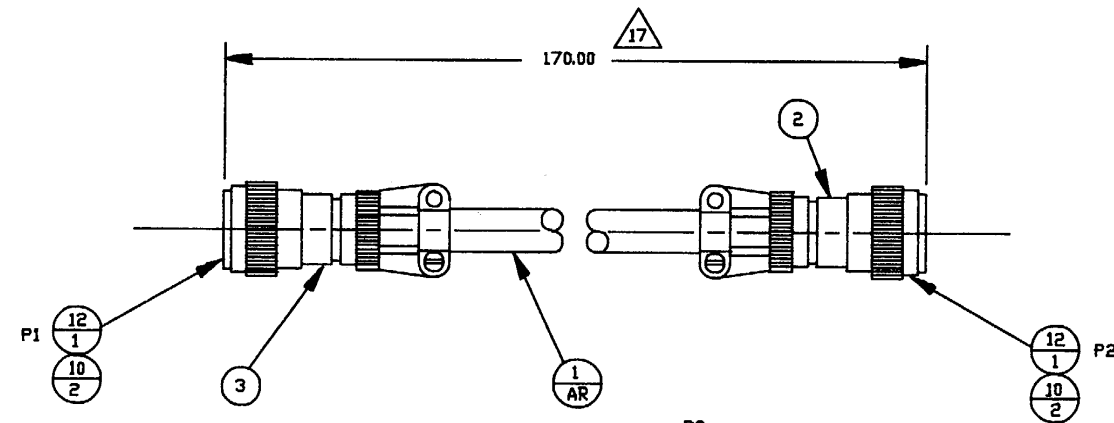

18 CABLE PREPARATION

SCALE : 2/1
BOTH ENDS

A3093646

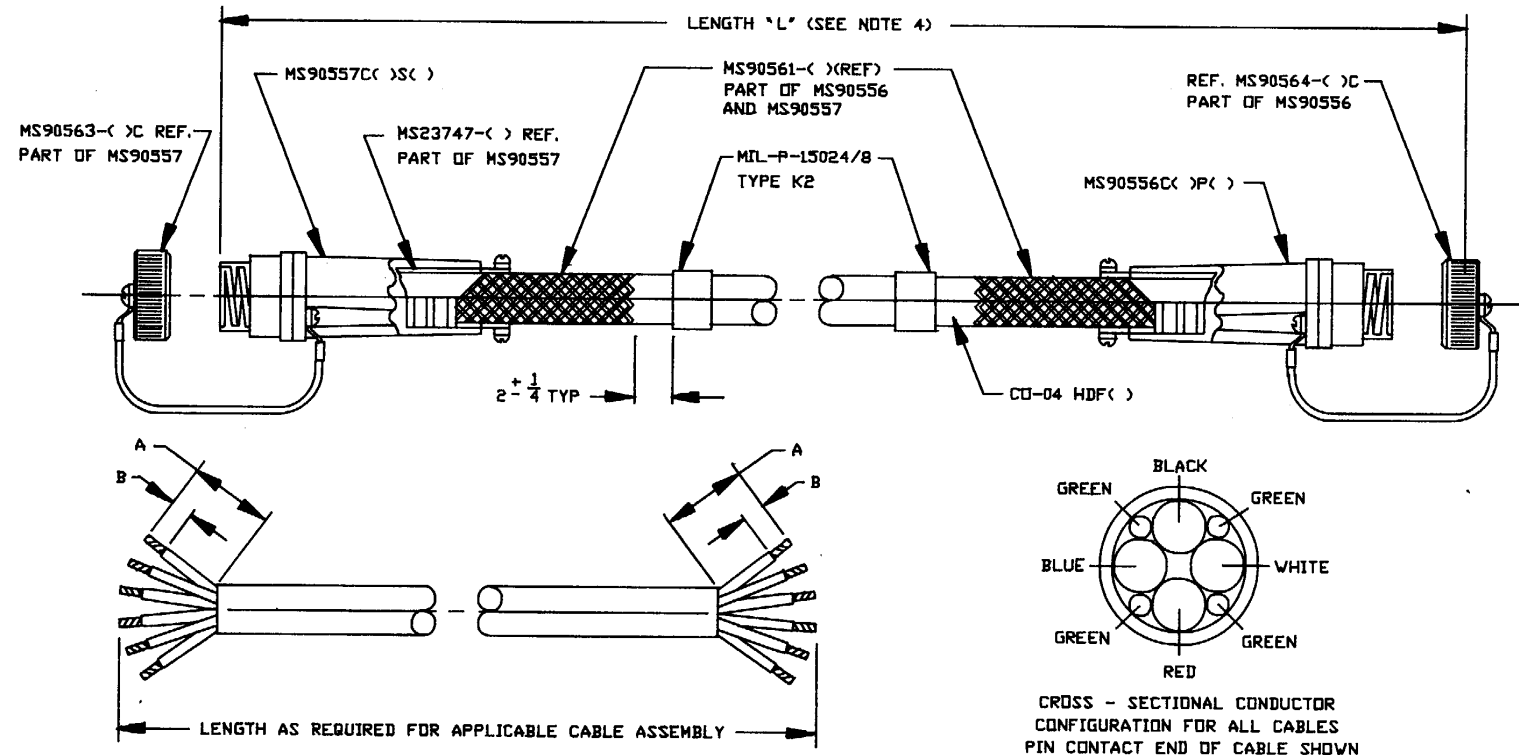

CABLE PREPARATION

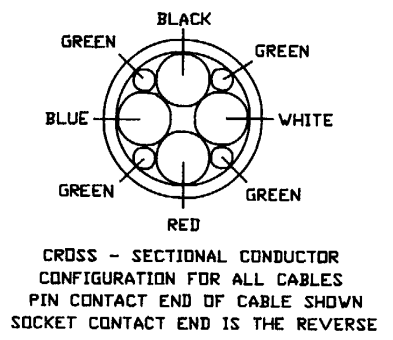

WIRING DIAGRAM

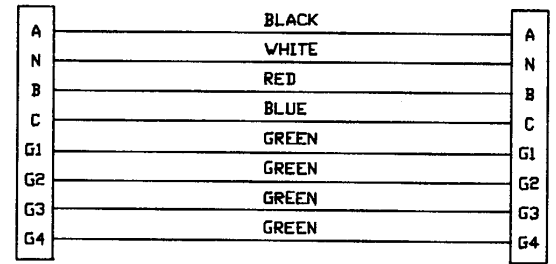

GRP 9 THRU GRP 12 ASSEMBLIES
GRP 17 THRU GRP 20 ASSEMBLIES

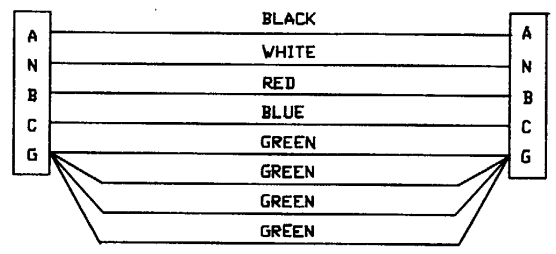

GRP 1 THRU GRP 9 ASSEMBLIES
WIRING DIAGRAM

CABLE ASSEMBLY NUMBER	CABLE NOMENCLATURE	COLOR	A ± 1/8	B + 0 - 1/16
SC-D-883963 GRP 1 THRU GRP 4	CO-04 HDF (4/6-4/12R) 1090 CO-04 HDF (4/8-4/12R) 0915	WHITE, BLACK, RED, BLUE GREEN, GREEN, GREEN, GREEN	2-3/4 3-1/4	3/4 25/32
SC-D-883963 GRP 5 THRU GRP 8	CO-04 HDF (4/4-4/12R) 1290 CO-04 HDF (4/6-4/12R) 1090	WHITE, BLACK, RED, BLUE GREEN, GREEN, GREEN, GREEN	2-3/4 3-1/4	3/4 25/32
SC-D-883963 GRPS 9, 10 11 & 12	CO-04 HDF (4/1-4/8R) 1620 CO-04 HDF (4/2-4/10R) 1465	WHITE, BLACK, RED, BLUE GREEN, GREEN, GREEN, GREEN	4-5/16 4-3/16	3/4 3/4
SC-D-883963 GRPS 17, 18 19 & 20	CO-04 HDF (4/0000-4/4R) 2380	WHITE, BLACK, RED, BLUE GREEN, GREEN, GREEN, GREEN	5 5-1/2	3/4 3/4

5. CONNECTOR ASSEMBLY
- 5-1 REASSEMBLE ACCESSORY PARTS IN REVERSE ORDER OF THAT LISTED IN PARA. 2-3 ABOVE.
 - 5-2 TIGHTEN THE GLAND NUT (LEFT HAND THREAD) UNTIL A METAL TO METAL SEATING WITH THE SHELL OCCURS. WHEN TIGHTENING THE GLAND NUT ON A MAXIMUM DIAMETER CABLE A METAL TO METAL SEATING MAY NOT OCCUR ON THE INITIAL TIGHTENING. A SECOND TIGHTENING IS THEREFORE NECESSARY AFTER THE CABLE HAS BEEN ALLOWED TO 'COLD FLOW' (APPROX. 12 HOURS).

ASSEMBLY INSTRUCTIONS :

1. CONNECTOR PREPARATION
 - 1-1 VISUALLY INSPECT THE CABLE, CONNECTORS AND CONTACTS FOR IDENTIFYING PART NUMBERS AND FOR DAMAGED PIECES.
 - 1-2 CLEAN INSERTS, CONTACTS AND INSIDE SURFACES OF SHELL WITH SOFT, LINT FREE CLOTH DAMPENED WITH DENATURATED ETHYL ALCOHOL. IF THE SHELL THREAD LUBRICATION HAS BEEN REMOVED DURING CLEANING, REAPPLY A THIN FILM OF LIGHT GREASE TO THE SHELL THREADS BEFORE FINAL ASSEMBLY.
2. CABLE PREPARATION
 - 2-1 CABLE SHOULD BE CUT CLEAN AND SQUARE AT THE LENGTH INDICATED.
 - 2-2 STRIP CABLE JACKET IN ACCORDANCE WITH DIMENSION 'A'. CUT AROUND JACKET AND PULL IT OFF. IF JACKET IS NOT EASILY REMOVED, MAKE AN ADDITIONAL CUT LENGTHWISE AND PEEL OFF. AVOID CUTTING OR NICKING INDIVIDUAL CONDUCTOR INSULATION.
 - 2-3 INSTALL GLAND NUT, CABLE GRIP, SEALING GLAND AND CABLE HOUSING OVER CABLE JACKET.
 - 2-4 DETERMINE LAY OF CABLE ENDS AND SELECT THE END OF CABLE FOR ASSEMBLY OF PIN CONTACTS IN ACCORDANCE WITH CROSS-SECTIONAL CONFIGURATION DIAGRAM. LAY OF SOCKET CONTACT END OF CABLE WILL BE THE REVERSE OF THE SEQUENCE SHOWN.
 - 2-5 STRIP INSULATION OF INDIVIDUAL CONDUCTORS IN ACCORDANCE WITH DIMENSION 'B'. HOT WIRE STRIPPING METHODS ARE RECOMMENDED.
3. CRIMPING CONTACTS
 - 3-1 SELECT PIN CONTACTS FOR ASSEMBLY TO EACH CONNECTOR EXERCISING CARE TO INSURE THAT PHASE CONTACTS AND NEUTRAL CONTACTS ARE ASSEMBLED TO THE PROPER CONDUCTOR IN ACCORDANCE WITH THE WIRING DIAGRAM AND THE MS IDENTIFICATION APPEARING ON THE INDIVIDUAL CONTACT SHIPPING PACKAGE.
 - 3-2 INSERT STRIPPED END OF CONDUCTOR INTO CONTACT WIRE WELL SO THAT CONDUCTOR IS POSITIVELY BOTTOMED AND BARE STANDS ARE VISIBLE THRU THE WIRE WELL INSPECTION HOLE.
 - 3-3 SELECT PROPER CRIMPING DIE FOR CONTACT FROM CRIMP TOOL DATA TABLE. WITH CONNECTOR IN PLACE. INSERT CONTACT INTO TOOL AND CLOSE CRIMPING DIE TO FORM A UNIFORM CRIMP.
 - 3-4 ASSEMBLE SOCKET CONTACTS TO OPPOSITE ENDS OF CONNECTORS USING THE SAME TECHNIQUES DESCRIBED IN 3-1 TO 3-4 ABOVE.
4. CONTACT ASSEMBLY
 - 4-1 EXERCISE EXTREME CARE TO INSURE THAT THE CONTACT RETENTION SHOULDERS OF ALL WIRED CONTACTS ARE IN THE SAME PLANE SO AS TO AVOID DAMAGING THE CONTACT RETENTION BUSHINGS DURING ASSEMBLY OF CONTACTS INTO REAR SPACER.
 - 4-2 ALIGN THE CONTACTS WITH THE APPROPRIATE HOLES IN REAR SPACER AND SIMULTANEOUSLY INSERT CONTACTS IN SPACER ASSEMBLY UNTIL CONTACTS LOCK INTO CONTACT RETAINING BUSHING.
 - 4-3 ALIGN FRONT INSERT WITH SHELL SO THAT LARGE KEY OR INSERT MATES WITH LARGE KEYWAY IN SHELL. PUSH INSERT INTO SHELL UNTIL IT BOTTOMS.
 - 4-4 ALIGN CONTACTS WITH PROPER INSERT HOLES AND SLIDE CONTACTS INTO INSERT HOLES UNTIL SPACER BUTTS AGAINST INSERT.

SC-D-883963

TABLE 1		LENGTH
CABLE ASSEMBLY NO.		'L' FEET
SC-D-883963	GRP1-1	10
	GRP1-2	25
	GRP1-3	50
	GRP1-4	100
	GRP2-1	10
	GRP2-2	25
	GRP2-3	50
	GRP2-4	100
	GRP3-1	10
	GRP3-2	25
	GRP3-3	50
	GRP3-4	100
	GRP4-1	10
	GRP4-2	25
	GRP4-3	50
	GRP4-4	100
	GRP5-1	10
	GRP5-2	25
	GRP5-3	50
	GRP5-4	100
	GRP6-1	10
	GRP6-2	25
	GRP6-3	50
	GRP6-4	100
	GRP7-1	10
	GRP7-2	25
	GRP7-3	50
	GRP7-4	100
	GRP8-1	10
	GRP8-2	25
	GRP8-3	50
	GRP8-4	100
	GRP9-1	10
	GRP9-2	25
	GRP9-3	50
	GRP10-1	10
	GRP10-2	25
	GRP10-3	50
	GRP11-1	10
	GRP11-2	25
	GRP11-3	50
	GRP12-1	10
	GRP12-2	25
	GRP12-3	50
	GRP17-1	10
	GRP17-2	25
	GRP18-1	10
	GRP18-2	25
	GRP19-1	10
	GRP19-2	25
	GRP20-1	10
	GRP20-2	25

IDENTIFICATION BAND MARKING SEE NOTE 1	LD. BAND NOTE 1 9 REQ'D	CABLE, MIL-C-3432 LENGTH AS REQ'D SEE NOTE 7	CONNECTOR, PLUG ELECTRICAL, STRAIGHT MIL-C-22992 1 REQ'D NOTE 3	CONNECTOR, PLUG ELECTRICAL, CABLE CONNECTING, MIL-C-22992 1 REQ'D NOTE 3	COVER, ELECTRICAL CONNECTOR, RECEPT MIL-C-22992 1 REQ'D NOTE 3 REF. PART OF MS90557	COVER, ELECTRICAL CONNECTOR, PLUG MIL-C-22992 1 REQ'D NOTE 3 REF. PART OF MS90556	GRIP, CABLE, WOVEN STRAIN RELIEF MIL-C-22992 2 REQ'D NOTE 3 REF. PART OF MS90556 & MS90557	GLAND, CABLE SEALING MIL-C-22992 REF. PART OF MS90556 & MS90557
SC-D-883963 GRP 1 (-1THRU-4) 40AMP 60HZ 120/208V 3Ø W/EQUIP. GROUND (_FT.)	MIL-P-15024/B TYPE K2	CD-04HDF(4/8-4/12R)0915	MS90556C28412P	MS90557C26412S	MS90563-1C	MS90564-1C	MS90561-1	MS23747-12
SC-D-883963 GRP 2 (-1THRU-4) 40AMP 400HZ 120/208V 3Ø W/EQUIP. GROUND (_FT.)		(4/6-4/12R)090	MS90556C28413PY	MS90557C28413SY	MS90563-1	MS90564-1	-2	-2
SC-D-883963 GRP 3 (-1THRU-4) 40AMP 60HZ 240/416V 3Ø W/EQUIP. GROUND (_FT.)		(4/8-4/12R)0915	MS90556C28512P	MS90557C28512S	MS90563-1C	MS90564-1C	-1	-12
SC-D-883963 GRP 4 (-1THRU-4) 40AMP 400HZ 240/416V 3Ø W/EQUIP. GROUND (_FT.)		(4/6-4/12R)090	MS90556C28513PY	MS90557C28513SY	MS90563-1C	MS90564-1C	-2	-2
SC-D-883963 GRP 5 (-1THRU-4) 60AMP 60HZ 120/208V 3Ø W/EQUIP. GROUND (_FT.)		(4/6-4/12R)090	MS90556C32412P	MS90557C32412S	MS90563-4C	MS90564-4	-2	-2
SC-D-883963 GRP 6 (-1THRU-4) 60AMP 400HZ 120/208V 3Ø W/EQUIP. GROUND (_FT.)		(4/4-4/12R)1290	MS90556C32413PY	MS90557C32413SY	MS90563-4C	MS90564-4C	-13	-13
SC-D-883963 GRP 7 (-1THRU-4) 60AMP 60HZ 240/416V 3Ø W/EQUIP. GROUND (_FT.)		(4/6-4/12R)090	MS90556C32512P	MS90557C32512S	MS90563-4C	MS90564-4C	-2	-2
SC-D-883963 GRP 8 (-1THRU-4) 60AMP 400HZ 240/416V 3Ø W/EQUIP. GROUND (_FT.)		(4/4-4/12R)1290	MS90556C32513PY	MS90557C32513SY	MS90563-4C	MS90564-4C	-13	-13
SC-D-883963 GRP 9 (-1THRU-3) 100AMP 60HZ 120/208V 3Ø W/EQUIP. GROUND (_FT.)		(4/2-4/10R)1465	MS90556C44412P	MS90557C44412S	MS90563-7C	MS90564-7C	-15	-15
SC-D-883963 GRP10 (-1THRU-3) 100AMP 400HZ 120/208V 3Ø W/EQUIP. GROUND (_FT.)		(4/1-4/8R)1620	MS90556C44413PW	MS90557C44413SW	MS90563-7C	MS90564-7C	-16	-16
SC-D-883963 GRP11 (-1THRU-3) 100AMP 60HZ 240/416V 3Ø W/EQUIP. GROUND (_FT.)		(4/2-4/10R)1465	MS90556C44512P	MS90557C44512S	MS90563-7C	MS90564-7C	-15	-15
SC-D-883963 GRP12 (-1THRU-3) 100AMP 400HZ 240/416V 3Ø W/EQUIP. GROUND (_FT.)		(4/1-4/8R)1620	MS90556C44513PW	MS90557C44513SW	MS90563-7C	MS90564-7C	-16	-16
SC-D-883963 GRP17 (-1 & -2) 200AMP 60HZ 120/208V 3Ø W/EQUIP. GROUND (_FT.)		(4/0000-4/4R)2380	MS90556C52413P	MS90557C52413S	MS90563-11C	MS90564-11C	-18	-19
SC-D-883963 GRP18 (-1 & -2) 200AMP 400HZ 120/208V 3Ø W/EQUIP. GROUND (_FT.)		(4/0000-4/4R)2380	MS90556C52413PW	MS90557C52413SW	MS90563-11C	MS90564-11C	-18	-19
SC-D-883963 GRP19 (-1 & -2) 200AMP 60HZ 240/416V 3Ø W/EQUIP. GROUND (_FT.)		(4/0000-4/4R)2380	MS90556C52513P	MS90557C52513S	MS90563-11C	MS90564-11C	-18	-19
SC-D-883963 GRP20 (-1 & -2) 200AMP 400HZ 240/416V 3Ø W/EQUIP. GROUND (_FT.)		(4/0000-4/4R)2380	MS90556C52513PW	MS90557C52513SW	MS90563-11C	MS90564-11C	-18	-19

SUGGESTED SOURCES OF SUPPLY :

CABLING - BRAND-REX CO. WILLIHANTIC, CONN.
 CONNECTORS - BENDIX CORP. ELECTRICAL COMPONENTS DIV. SYDNEY, N.Y.
 BUNKER-RAND CORP. AMPHEDOL CONNECTOR DIV. BROADVIEW, ILL.

NOTES :

- IDENTIFICATION BANDS SHALL BE MARKED WITH APPLICABLE NOMENCLATURE INCLUDING LENGTH IN FEET. OR INDIVIDUAL CONDUCTOR IDENTIFICATION AS SHOWN. CHARACTERS AND MARKING SHALL BE IN ACCORDANCE WITH MIL-M-81531. CABLE ASSEMBLIES SHALL HAVE TWO IDENTIFICATION BANDS.
- CONNECTORS SHALL MEET THE QUALITY ASSURANCE PROVISIONS OF MIL-C-22992.
- CABLE ASSEMBLY SHALL BE WIRED IN ACCORDANCE WITH WIRING DIAGRAM AS SHOWN. SECURELY SOLDER OR CRIMP ALL CONTACT TERMINATIONS. IF SOLDERED, USE SOLDER COMPOSITIONS Sn 60, TYPE S OR RMA PER QQ-S-571. WHEN TYPE S IS USED, ROSIN FLUX WILL BE EMPLOYED.
- LENGTH 'L' SHALL BE AS SPECIFIED IN TABLE 1. TOLERANCE FOR LENGTH DIMENSIONS SHALL BE : 10' & 25' CABLES $+0''-6''$, 50' CABLES $+1'0''-0''$, 100' CABLES $+2'-0''-0''$.
- FINISHED CABLE ASSEMBLY SHALL BE IN ACCORDANCE WITH SPEC MIL-C-3885.
- MAXIMUM CABLE LENGTHS SHOWN IN TABLE 1. HAVE BEEN DETERMINED BY CONSIDERATION OF TOTAL WEIGHT AND/OR VOLTAGE DROP. INTERIM LENGTHS ARE BASED ON OPTIMUM SPACING BETWEEN POWER SOURCE AND USING EQUIPMENT.
- CABLE SHALL MEET THE REQUIREMENTS OF AND WILL BE CONSTRUCTED IN ACCORDANCE WITH MIL-C-3432 EXCEPT THAT IDENTIFYING CONDUCTOR COLORS SHALL BE AS SHOWN ON THIS DRAWING. UNINSULATED GROUND WIRES SHALL HAVE A GREEN COVER OF BRAID, RUBBER OR PLASTIC AS REQUIRED BY MIL-C-3432.

CABLE ASSEMBLY NO.	CONTACTS		CRIMPING TOOL MS25441		CRIMPING TOOL #4008 AS SUPPLIED BY PICO CRIMPING TOOL CO.	
	A,B,C	PIN	DIE ASSEMBLY	LOCATOR	DIE ASSEMBLY	
SC-D-883963 GRPS 1 - 4	A,B,C N,G	MS90559-11 -12	MS90560 -7 -7	4297-6 4297-6	414DA-6N 414DA-6N	
SC-D-883963 GRPS 5 - 8	A,B,C N G	-8 -9 -12	-5 -5 -7	MS3150-4 MS3150-4 4297-6	4297-5 4297-5 414DA-6N	414DA-4N 414DA-4N 414DA-6N
SC-D-883963 GRPS 9 - 12	A,B,C N G1-2-3-4	-5 -6 -14	-3 -3 -8	MS3150-0 MS3150-0 4297-6	4297-3 4297-3 4297-6	414DA-1/DN 414DA-1/DN 414DA-6N
SC-D-883963 GRPS 17 - 20	A,B,C N G1-2-3-4	-1 -2 -13	-1 -1 -9	4297-1 4297-1 MS3150-4	4297-1 4297-1 4297-5	414DA-4/DN-1 414DA-4/DN-1 414DA-4N

SC-D-883963

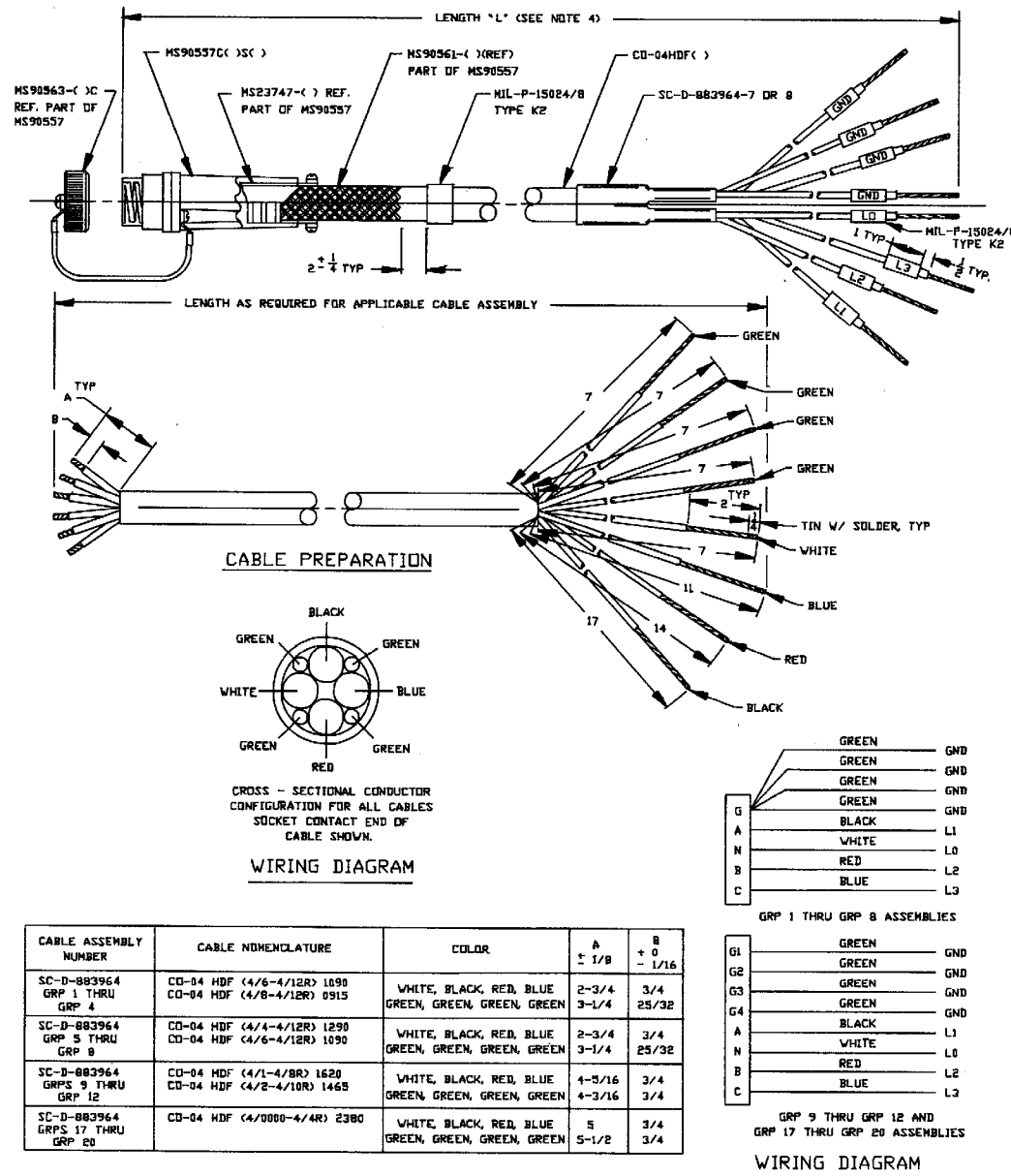

ASSEMBLY INSTRUCTIONS :

1. CONNECTOR PREPARATION
 - 1-1 VISUALLY INSPECT THE CABLE, CONNECTORS AND CONTACTS FOR IDENTIFYING PART NUMBERS AND FOR DAMAGED PIECES.
 - 1-2 CLEAN INSERTS, CONTACTS AND INSIDE SURFACES OF SHELL WITH SOFT, LINT FREE CLOTH DAMPENED WITH DENATURATED ETHYL ALCOHOL. IF THE SHELL THREAD LUBRICATION HAS BEEN REMOVED DURING CLEANING, REAPPLY A THIN FILM OF LIGHT GREASE TO THE SHELL THREADS BEFORE FINAL ASSEMBLY.
2. CABLE PREPARATION
 - 2-1 CABLE SHOULD BE CUT CLEAN AND SQUARE AT THE LENGTH INDICATED.
 - 2-2 STRIP CABLE JACKET IN ACCORDANCE WITH DIMENSION 'A'. CUT AROUND JACKET AND PULL IT OFF. IF JACKET IS NOT EASILY REMOVED, MAKE AN ADDITIONAL CUT LENGTHWISE AND PEEL OFF. AVOID CUTTING OR NECKING INDIVIDUAL CONDUCTOR INSULATION.
 - 2-3 INSTALL GLAND NUT, CABLE GRIP, SEALING GLAND AND CABLE HOUSING OVER CABLE JACKET.
 - 2-4 DETERMINE LAY OF CABLE ENDS AND SELECT THE END OF CABLE FOR ASSEMBLY OF PIN CONTACTS IN ACCORDANCE WITH CROSS-SECTIONAL CONFIGURATION DIAGRAM. LAY OF SOCKET CONTACT END OF CABLE WILL BE THE REVERSE OF THE SEQUENCE SHOWN.
 - 2-5 STRIP INSULATION OF INDIVIDUAL CONDUCTORS IN ACCORDANCE WITH DIMENSION 'B'. HOT WIRE STRIPPING METHODS ARE RECOMMENDED.
3. CRIMPING CONTACTS
 - 3-1 SELECT PIN CONTACTS FOR ASSEMBLY TO EACH CONNECTOR EXERCISING CARE TO INSURE THAT PHASE CONTACTS AND NEUTRAL CONTACTS ARE ASSEMBLED TO THE PROPER CONDUCTOR IN ACCORDANCE WITH THE WIRING DIAGRAM AND THE MS IDENTIFICATION APPEARING ON THE INDIVIDUAL CONTACT SHIPPING PACKAGE.
 - 3-2 INSERT STRIPPED END OF CONDUCTOR INTO CONTACT WIRE WELL SO THAT CONDUCTOR IS POSITIVELY BOTTOMED AND BARE STRANDS ARE VISIBLE THRU THE WIRE WELL INSPECTION HOLE.
 - 3-3 SELECT PROPER CRIMPING DIE FOR CONTACT FROM CRIMP TOOL DATA TABLE. WITH CONNECTOR IN PLACE, INSERT CONTACT INTO TOOL AND CLOSE CRIMPING DIE TO FORM A UNIFORM CRIMP.
 - 3-4 ASSEMBLE SOCKET CONTACTS TO OPPOSITE ENDS OF CONNECTORS USING THE SAME TECHNIQUES DESCRIBED IN 3-1 TO 3-4 ABOVE.
4. CONTACT ASSEMBLY
 - 4-1 EXERCISE EXTREME CARE TO INSURE THAT THE CONTACT RETENTION SHOULDERS OF ALL WIRED CONTACTS ARE IN THE SAME PLANE SO AS TO AVOID DAMAGING THE CONTACT RETENTION BUSHINGS DURING ASSEMBLY OF CONTACTS INTO REAR SPACER.
 - 4-2 ALIGN THE CONTACTS WITH THE APPROPRIATE HOLES IN REAR SPACER AND SIMULTANEOUSLY INSERT CONTACTS IN SPACER ASSEMBLY UNTIL CONTACTS LOCK INTO CONTACT RETAINING BUSHING.
 - 4-3 ALIGN FRONT INSERT WITH SHELL SO THAT LARGE KEY OR INSERT MATES WITH LARGE KEYWAY IN SHELL. PUSH INSERT INTO SHELL UNTIL IT BOTTOMS.
 - 4-4 ALIGN CONTACTS WITH PROPER INSERT HOLES AND SLIDE CONTACTS INTO INSERT HOLES UNTIL SPACER BUTTS AGAINST INSERT.
5. CONNECTOR ASSEMBLY
 - 5-1 REASSEMBLE ACCESSORY PARTS IN REVERSE ORDER OF THAT LISTED IN PARA. 2-3 ABOVE.
 - 5-2 TIGHTEN THE GLAND NUT (LEFT HAND THREAD) UNTIL A METAL TO METAL SEATING WITH THE SHELL OCCURS. WHEN TIGHTENING THE GLAND NUT ON A MAXIMUM DIAMETER CABLE A METAL TO METAL SEATING MAY NOT OCCUR ON THE INITIAL TIGHTENING. A SECOND TIGHTENING IS THEREFORE NECESSARY AFTER THE CABLE HAS BEEN ALLOWED TO "COLD FLOW" (APPROX. 12 HOURS).

SC-D-883964

TABLE 1		
CABLE ASSEMBLY NO.	LENGTH 'L' FEET	
SC-D-883964	GRP1-1	10
	GRP1-2	25
	GRP2-1	10
	GRP2-2	25
	GRP3-1	10
	GRP3-2	25
	GRP4-1	10
	GRP4-2	25
	GRP5-1	10
	GRP5-2	25
	GRP5-3	100
	GRP6-1	10
	GRP6-2	25
	GRP7-1	10
	GRP7-2	25
	GRP8-1	10
	GRP8-2	25
	GRP9-1	10
	GRP9-2	25
	GRP10-1	10
	GRP10-2	25
	GRP11-1	10
	GRP11-2	25
	GRP12-1	10
	GRP12-2	25
	GRP17-1	10
	GRP17-2	15
	GRP17-3	25
	GRP17-4	50
	GRP18-1	10
	GRP18-2	15
	GRP18-3	25
	GRP19-1	10
	GRP19-2	15
	GRP19-3	25
	GRP20-1	10
	GRP20-2	15
	GRP20-3	25
SC-D-883964	GRP3-3	50

IDENTIFICATION BAND MARKING SEE NOTE 1	I.D. BAND NOTE 1 9 REQ'D	CABLE, MIL-C-3432 LENGTH AS REQ'D SEE NOTE 8	CONNECTOR, PLUG ELECTRICAL, CABLE CONNECTING, MIL-C-22992 1 REQ'D NOTE 2	COVER, ELECTRICAL CONNECTOR, RECEPTACLE MIL-C-22992 1 REQ'D NOTE 2	GRIP, CABLE, WOVEN STRAIN RELIEF MIL-C-22992 1 REQ'D NOTE 2 REF. PART OF MS90537	GLAND CABLE SEALING MIL-C-22992 REF. PART OF MS90537	END SEAL NOTE 9 1 REQ'D
SC-D-883964 GRP 1-1&2 40AMP 60HZ 120/208V 3φ W/EQUIP. GROUND (..FT.)	MIL-P-15024/B TYPE K2	CD-D4HDF(4/8-4/12R)0915	MS90557C284J2S	MS50563-1C	MS50561-1	MS23747-12	SC-D-883964-7
SC-D-883964 GRP 2-1&2 40AMP 400HZ 120/208V 3φ W/EQUIP. GROUND (..FT.)		(4/6-4/12R)090	MS90557C284J3SY	MS50563-1C	MS50561-2	-2	-7
SC-D-883964 GRP 3-1&2 40AMP 60HZ 240/416V 3φ W/EQUIP. GROUND (..FT.)		(4/8-4/12R)0915	MS90557C285J2S	MS50563-1C	MS50561-1	-12	-7
SC-D-883964 GRP 4-1&2 40AMP 400HZ 240/416V 3φ W/EQUIP. GROUND (..FT.)		(4/6-4/12R)090	MS90557C285J3SY	MS50563-1C	MS50561-2	-2	-7
SC-D-883964 GRP 5-1-2&3 60AMP 60HZ 120/208V 3φ W/EQUIP. GROUND (..FT.)		(4/6-4/12R)090	MS90557C324J2S	MS50563-4C	MS50561-2	-2	-7
SC-D-883964 GRP 6-1&2 60AMP 400HZ 120/208V 3φ W/EQUIP. GROUND (..FT.)		(4/4-4/12R)1290	MS90557C324J3SY	MS50563-4C	MS50561-13	-13	-7
SC-D-883964 GRP 7-1&2 60AMP 60HZ 240/416V 3φ W/EQUIP. GROUND (..FT.)		(4/6-4/12R)090	MS90557C325J2S	MS50563-4C	MS50561-2	-2	-7
SC-D-883964 GRP 8-1&2 60AMP 400HZ 240/416V 3φ W/EQUIP. GROUND (..FT.)		(4/4-4/12R)1290	MS90557C325J3SY	MS50563-4C	MS50561-13	-13	-7
SC-D-883964 GRP 9-1,2&3 100AMP 60HZ 120/208V 3φ W/EQUIP. GROUND (..FT.)		(4/2-4/10R)1465	MS90557C444J2S	MS50563-7C	MS50561-15	-15	-8
SC-D-883964 GRP 10-1&2 100AMP 400HZ 120/208V 3φ W/EQUIP. GROUND (..FT.)		(4/1-4/8R)1620	MS90557C444J3SV	MS50563-7C	MS50561-16	-16	-8
SC-D-883964 GRP 11-1&2 100AMP 60HZ 240/416V 3φ W/EQUIP. GROUND (..FT.)		(4/2-4/10R)1465	MS90557C445J2S	MS50563-7C	MS50561-15	-15	-8
SC-D-883964 GRP 12-1&2 100AMP 400HZ 240/416V 3φ W/EQUIP. GROUND (..FT.)		(4/1-4/8R)1620	MS90557C445J3SV	MS50563-7C	MS50561-16	-16	-8
SC-D-883964 GRP 17-1-2-3&4 200AMP 60HZ 120/208V 3φ W/EQUIP. GROUND (..FT.)		(4/0000-4/4R)2380	MS90557C524J3S	MS50563-11C	MS50561-18	-19	-8
SC-D-883964 GRP 18-1-2&3 200AMP 400HZ 120/208V 3φ W/EQUIP. GROUND (..FT.)		(4/0000-4/4R)2380	MS90557C524J3SV	MS50563-11C	MS50561-18	-19	-8
SC-D-883964 GRP 19-1-2&3 200AMP 60HZ 240/416V 3φ W/EQUIP. GROUND (..FT.)		(4/0000-4/4R)2380	MS90557C525J3S	MS50563-11C	MS50561-18	-19	-8
SC-D-883964 GRP 20-1-2&3 200AMP 400HZ 240/416V 3φ W/EQUIP. GROUND (..FT.)		(4/0000-4/4R)2380	MS90557C525J3SV	MS50563-11C	MS50561-18	-19	-8

CRIMP TOOL DATA					
SC-D-883964 CABLE ASSEMBLY NO.	CONTACTS		CRIMPING TOOL MS2544J	CRIMPING TOOL #4008 AS SUPPLIED BY PICO CRIMPING TOOL CO.	
		SOCKETS	DIE ASSEMBLY	LOCATOR	DIE ASSEMBLY
SC-D-883964 GRPS 1 - 4	A,B,C N,G	MS90560-7 MS90560-7	---	4297-6 4297-6	414DA-6N 414DA-6N
SC-D-883964 GRPS 5 - 8	A,B,C,N G	MS90560-8 MS90560-7	MS3150-4	4297-5 4297-6	414DA-4N 414DA-6N
SC-D-883964 GRPS 9 - 12	A,B,C,N G1-2-3-4	MS90560-3 MS90560-8	MS3150-0	4297-3 4297-6	414DA-1/0N 414DA-6N
SC-D-883964 GRPS 17 - 20	A,B,C,N G1-2-3-4	MS90560-1 MS90560-9	---	4297-1 4297-5	414DA-4/0N-1 414DA-4N

SUGGESTED SOURCES OF SUPPLY :

CABLING

BRAND-REX CO.
WILLIMANTIC, CONN.

CONNECTORS

BENDIX CORP., ELECTRICAL COMPONENTS DIV.
SYDNEY, N.Y.
BUNKER-RAND CORP., AMPHENOL CONNECTOR DIV.
BROADVIEW, ILL.

- NOTES : 1. IDENTIFICATION BANDS SHALL BE MARKED WITH APPLICABLE NOMENCLATURE INCLUDING LENGTH IN FEET OR INDIVIDUAL CONDUCTOR IDENTIFICATION AS SHOWN. CHARACTERS AND MARKING SHALL BE IN ACCORDANCE WITH MIL-W-81531. CABLE ASSEMBLIES SHALL HAVE TWO IDENTIFICATION BANDS.
2. CONNECTORS SHALL MEET THE QUALITY ASSURANCE PROVISIONS OF MIL-C-22992.
3. CABLE ASSEMBLY SHALL BE WIRED IN ACCORDANCE WITH WIRING DIAGRAM AS SHOWN. SECURELY SOLDER OR CRIMP ALL CONTACT TERMINATIONS. IF SOLDERED, USE SOLDER COMPOSITIONS Sn 60, TYPE S OR RMA PER QQ-S-571. WHEN TYPE S IS USED, RDSIN FLUX WILL BE EMPLOYED.
4. LENGTH 'L' SHALL BE AS SPECIFIED IN TABLE 1. TOLERANCE FOR LENGTH DIMENSIONS SHALL BE : 10', 15' & 25' CABLE ^{+0' 6"} _{-0'}.
5. FINISHED CABLE ASSEMBLY SHALL BE IN ACCORDANCE WITH SPEC MIL-C-3885.
6. MAXIMUM CABLE LENGTHS SHOWN IN TABLE 1. HAVE BEEN DETERMINED BY CONSIDERATION OF TOTAL WEIGHT AND/OR VOLTAGE DROP. INTERIM LENGTHS ARE BASED ON OPTIMUM SPACING BETWEEN POWER SOURCE AND USING EQUIPMENT.
7. CABLE SHALL MEET THE REQUIREMENTS OF AND WILL BE CONSTRUCTED IN ACCORDANCE WITH MIL-C-3432 EXCEPT THAT IDENTIFYING CONDUCTOR COLORS SHALL BE AS SHOWN ON THIS DRAWING. UNINSULATED GROUND WIRES SHALL HAVE A GREEN COVER OF BRAID, RUBBER OR PLASTIC AS REQUIRED BY MIL-C-3234.
8.

AVG #	GROUNDING WIRES		WALL THICKNESS		
	NO. STRANDS	O.D.	MIN.	NOM.	COND O.D.
12	19	.090	.017	.020	.130
10	105	.120	.022	.025	.170
8	133	.166	.024	.027	.220
4	133	.257	.033	.036	.330
9. ITEMS SC-D-883964-7 AND SC-D-883964-8 SHALL BE P/N A3102J30-017. INSTALLATION AND BONDING OF END SEALS SHALL BE IN ACCORDANCE WITH MANUFACTURER'S INSTRUCTIONS AND SHALL BE CAPABLE OF WITHSTANDING WATER PRESSURE EQUIVALENT TO A SIX FOOT HEAD OF WATER FOR 48 HOURS CONTINUOUSLY WITH NO LEAKAGE.
10. WARNING
OPEN ENDS OF INDIVIDUAL CONDUCTORS WILL NOT PREVENT WATER LEAKAGE INTO CABLE & CABLE ADAPTERS. THEREFORE, SUBMERSION OR EXPOSURE TO RAIN OF THE STUB END OF THE CABLE ASSEMBLY IS PROHIBITED.

SC-D-883964

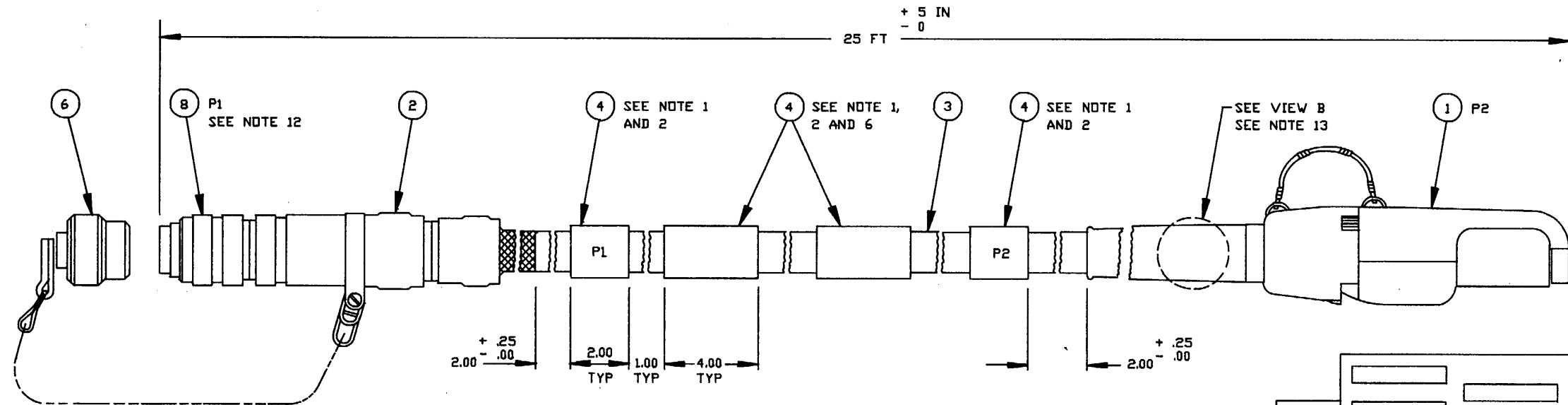

NOTES :

1. HEAT SHRINK INTO POSITION AS SHOWN.
2. MARKING SHALL BE IN ACCORDANCE WITH MIL-M-81531, (HOT STAMPED, BLACK).
3. MIL-STD-454, REQ. 5 AND 9 SHALL BE COMPLIED WITH
4. QTY IN INCHES.
5. QTY IN FEET.
6. MARK PRIME CONTRACT NO. AND PRIME MANUFACTURERS FSCM NO, LOCATED AS SHOWN ON DETAIL A.
7. CONTACTS M39029/56-351 SUPPLIED, CRIMP TOOL M22520/1-01, M22520/2-01, M22520/7-01, INSERTION TOOL M81969/14-02, M81969/8-05, EXTRACTION TOOL M81969/8-06, M81969/14-02; POSITIONER M22520/1-04 RED, M22520/07-08, M22520/2-10.
8. LEADS TO BE STRIPPED 1/4 INCH AT P1 END, STRIP 1/2 INCH AND TIN AT P2 END.
9. STRIP OUTER CABLE JACKET BACK 2.50 INCHES ON P1 END, 7.38 INCHES ON P2 END.
10. FIND NO. 7 (SEALING PLUG) TO BE INSERTED INTO SPARE CONTACT HH ON P1.
11. UNDERLINED CHARACTERS DENOTE LOWER CASE.
12. CABLE SHIELD TO BE TERMINATED PER SM-A-811234 PROCEDURE 2.
13. PRIOR TO POSITIONING BOOT OF CONNECTOR, TRIM SHIELD FLUSH TO OUTER JACKET, COVER WITH FIND NO. 5 AND HEAT SHRINK INTO POSITION AS SHOWN.

CONTRACT NO.
SEE NOTE 2 AND 6

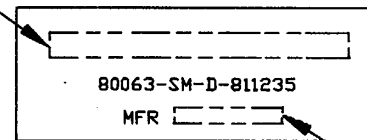

DETAIL A

FSCM NO.
SEE NOTES 2 AND 6

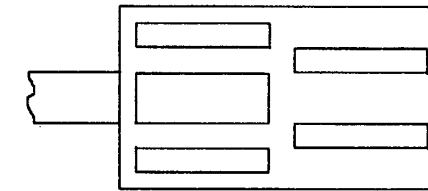

FRONT VIEW P2

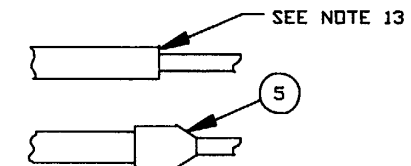

VIEW B

QTY REQD	FIND NO.	FSCM NO.	PART NUMBER OR IDENTIFYING NO.	NOMENCLATURE OR DESCRIPTION	SPEC/STD	NOTE
				PARTS LIST		
	9	81348	SN60WRMAP2	SOLDER, TIN ALLOY	QQ-S-571	
1	8		MS27467T23B53S	CONN, PLUG, ELEC	MIL-C-38999	
1	7	96906	MS27488-20	PLUG, SEALING, ELEC		10
1	6	80063	SM-A-838702-1	COVER, PROTECTIVE, ELEC		
2	5		CL1,750ID,BLK	INSUL SLVG	MIL-I-23053/5	4
12	4		CL1,750ID,YEL	INSUL SLVG	MIL-I-23053/5	4
26	3	81349	WM-130A/G	CABLE, TELEPHONE	MIL-C-55036	5, 9
1	2		SM-A-838108-3	ADAPTER		
1	1	80063	SM-D-159141	CONNECTOR, PLUG, ELECTRICAL		

SM-D-811235'

TABLE 1						
WIRE FIND NO.	PR NO.	WIRE COLOR	NOTES	FROM	TO	NOTES
3	1	BL/W	7, 8	P1-A	P2-1A	8
		BL/W/W	7, 8	P1-B	P2-1B	8
	2	Q/W	7, 8	P1-C	P2-2A	8
		Q/W/W	7, 8	P1-D	P2-2B	8
	3	G/W	7, 8	P1-E	P2-3A	8
		G/W/W	7, 8	P1-F	P2-3B	8
	4	BR/W	7, 8	P1-G	P2-4A	8
		BR/W/W	7, 8	P1-H	P2-4B	8
	5	GY/W	7, 8	P1-J	P2-5A	8
		GY/W/W	7, 8	P1-K	P2-5B	8
	6	BL/R	7, 8	P1-L	P2-6A	8
		BL/R/R	7, 8	P1-M	P2-6B	8
	7	Q/R	7, 8	P1-N	P2-7A	8
		Q/R/R	7, 8	P1-P	P2-7B	8
	8	G/R	7, 8	P1-R	P2-8A	8
		G/R/R	7, 8	P1-S	P2-8B	8
	9	BR/R	7, 8	P1-T	P2-9A	8
		BR/R/R	7, 8	P1-U	P2-9B	8
	10	GY/R	7, 8	P1-V	P2-10A	8
		GY/R/R	7, 8	P1-W	P2-10B	8
	11	BL/BK	7, 8	P1-X	P2-11A	8
		BL/BK/BK	7, 8	P1-Y	P2-11B	8
	12	Q/BK	7, 8	P1-Z	P2-12A	8
		Q/BK/BK	7, 8	P1-A	P2-12B	8
	13	G/BK	7, 8	P1-B	P2-13A	8
		G/BK/BK	7, 8	P1-C	P2-13B	8
	14	BR/BK	7, 8	P1-D	P2-14A	8
		BR/BK/BK	7, 8	P1-E	P2-14B	8
	15	GY/BK	7, 8	P1-F	P2-15A	8
		GY/BK/BK	7, 8	P1-G	P2-15B	8
	16	B/Y	7, 8	P1-H	P2-16A	8
		B/Y/Y	7, 8	P1-K	P2-16B	8
	17	Q/Y	7, 8	P1-M	P2-17A	8
		Q/Y/Y	7, 8	P1-N	P2-17B	8
	18	G/Y	7, 8	P1-P	P2-18A	8
		G/Y/Y	7, 8	P1-Q	P2-18B	8
	19	BR/Y	7, 8	P1-R	P2-19A	8
		BR/Y/Y	7, 8	P1-S	P2-19B	8
	20	GY/Y	7, 8	P1-T	P2-20A	8
		GY/Y/Y	7, 8	P1-U	P2-20B	8

TABLE 1						
WIRE FIND NO.	PR NO.	WIRE COLOR	NOTES	FROM	TO	NOTES
3	21	BL/V	7, 8	P1-V	P2-21A	8
		BL/V/V	7, 8	P1-W	P2-21B	8
	22	Q/V	7, 8	P1-X	P2-22A	8
		Q/V/V	7, 8	P1-Y	P2-22B	8
	23	G/V	7, 8	P1-Z	P2-23A	8
		G/V/V	7, 8	P1-AA	P2-23B	8
	24	BR/V	7, 8	P1-BB	P2-24A	8
		BR/V/V	7, 8	P1-CC	P2-24B	8
	25	GY/V	7, 8	P1-DD	P2-25A	8
		GY/V/V	7, 8	P1-EE	P2-25B	8
	26	R/W	7, 8	P1-FF	P2-26A	8
		R/W/W	7, 8	P1-GG	P2-26B	8

SM-D-811235

RECOMMENDED CHANGES TO EQUIPMENT TECHNICAL PUBLICATIONS



THEN... JOT DOWN THE DOPE ABOUT IT ON THIS FORM, CAREFULLY TEAR IT OUT, FOLD IT AND DROP IT IN THE MAIL!

SOMETHING WRONG WITH THIS PUBLICATION?

FROM: (PRINT YOUR UNIT'S COMPLETE ADDRESS)

DATE SENT

PUBLICATION NUMBER

PUBLICATION DATE

PUBLICATION TITLE

BE EXACT... PIN-POINT WHERE IT IS

PAGE NO.

PARA-GRAPH

FIGURE NO.

TABLE NO.

IN THIS SPACE TELL WHAT IS WRONG AND WHAT SHOULD BE DONE ABOUT IT:

TEAR ALONG PERFORATED LINE

PRINTED NAME, GRADE OR TITLE, AND TELEPHONE NUMBER

SIGN HERE:

DA FORM 2028-2
1 JUL 79

PREVIOUS EDITIONS ARE OBSOLETE.

P.S.—IF YOUR OUTFIT WANTS TO KNOW ABOUT YOUR RECOMMENDATION MAKE A CARBON COPY OF THIS AND GIVE IT TO YOUR HEADQUARTERS.

